

SiNET™ MULTI-AXIS MOTION CONTROL



PROGRAMMABLE NETWORKING HUB WITH I/O, POINT-AND-CLICK SOFTWARE, STAND-ALONE CONTROL

HUB 444
\$320



Software
and Cables
Included!

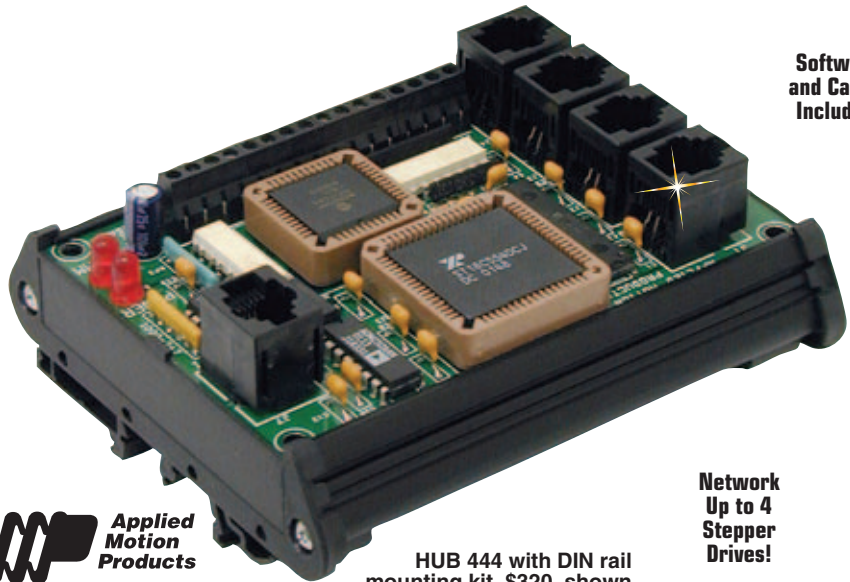

Network
Up to 4
Stepper
Drives!

**Applied
Motion
Products**
motors • drives • controls

HUB 444 with DIN rail
mounting kit, \$320, shown
smaller than actual size.

- Networks All Applied Motion Stepper or Servo Si™ Products for Multi-Axis Motion Applications
- For Real-Time Execution of Commands Downloaded from a Host PC or PLC Using the Si Command Language™ (SCL)
- Programmable for Stand-Alone Single or Multi-Axis Operations with Easy-to-Use SiNet Hub Programmer™ Windows Software (Software and Programming Cable Included)
- Can Also Act as a Router, Allowing a Host Computer or PLC to Control 1 to 4 Drives and the On-Board I/O Using Si Command Language™ (SCL)
- Communication via RS232
- 4 Optically Isolated Programmable Inputs, 5 to 24 Vdc
- 4 Optically Isolated Programmable Outputs, 24 Vdc, 100 mA
- Hub Programs and Host Computers Also Have Access to the I/O in Each Drive, Typically 8 Inputs and 3 Outputs per Drive
- Screw Terminal Connectors Make I/O Wiring Easy
- RJ11 “Telephone-Style” Connectors for Drives and PC for Easy, Reliable Connections
- Powered by Drive #1, No External Power Supply Required
- Can Control and Power Optional MMI (Operator Terminal)
- DIN Rail Mounting Kit Makes Installation Easy

The SiNet™ Hub 444 allows up to 4 Stepper or Servo Si™ drives to be controlled in host mode from a single PC or PLC's RS232 serial port or will run in stand-alone mode. Each indexer-drive acquires its unique address from the port to which it is

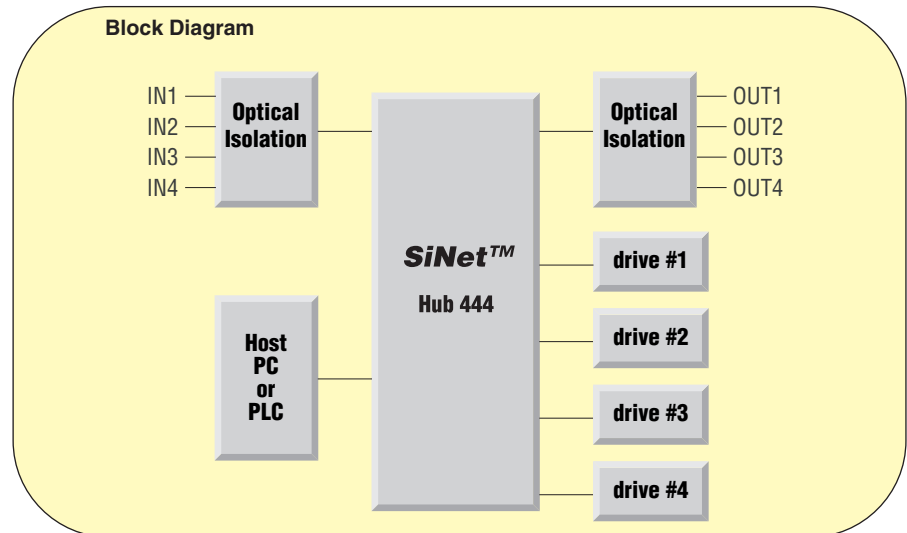
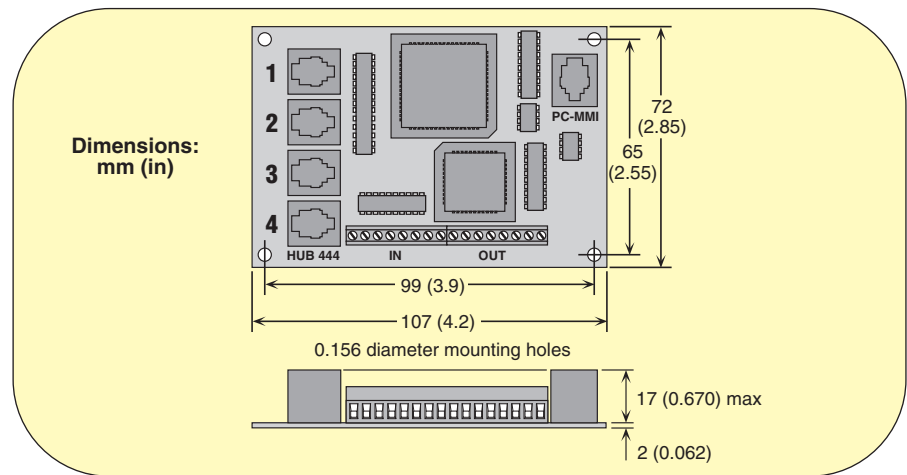



connected. This simple addressing scheme minimizes the cost of the drives, and more importantly, the cost of configuring and/or replacing drives in your system. Connections are made with low cost, reliable RJ11 cabling. Any of our popular, cost effective programmable Stepper or Servo Si™ drives or Si™ motor controls can be used with the SiNet™ Hub 444. By choosing the power level and features you need for each axis of your application, SiNet™ can provide a cost effective single or multi-axis motion solution. The SiNet™ Hub 444 is powered by the drive that's connected to port #1, saving you the cost and installation expense of using a separate power supply. Our Si Command Language™ (SCL) allows a host PC or PLC to execute relative, absolute and homing moves, make status inquiries, sample inputs, set outputs, and more. If your application requires a single axis to operate in "host mode", you can connect any of our programmable Si™ drives directly to your PC via the SiNet™ Hub 444 and invoke the Si Command Language™ (SCL). Our SiNet Programmer™ Windows software allows the user to create and store multi-axis motion control programs in the SiNet™ Hub 444 and run them without a PC, thus allowing the user to create a complex multi-axis motion system controlled from an operator interface or trigger.

SPECIFICATIONS

Power: Power is provided by Si™ indexer-drive on Port 1. Provides up to 50 mA for MMI via PC/MMI port.

Communication:

Ports 1 to 4: RS232, 9600 bps, 8 data bits, one stop bit, no parity

MMI: Same

PC in Router Mode: Same

PC When Running SiNet

Programmer Software: 19200 bps

Max Cable Length, Any Port: 15 m (50')

Physical: Constructed on 2 mm (0.062") fiberglass printed circuit board with 4 x 4 mm (0.156") mounting holes (nylon spacers included), 106.68 x 72.39 x 18.288 mm (4.2 x 2.85 x 0.72"), two red LEDs

Operating Temperature Range: 0 to 70°C (32 to 158°F)

DIN Rail Mounting Kit:

Fits ENS0022 35 mm (1.4") DIN rail

Program:

Move Distances: ±16,000,000 steps

Move Speeds: 0.025 to 50 rev/sec

Accel/Decel Range: 1 to 3000 rev/sec/sec

Time Delays: 0.01 to 300 seconds
Loop Counts: 1 to 65,535
Number of Nested Loops: Unlimited
Number of Subroutines: Unlimited
Subroutine Stack Depth: 5 calls max
Number of Comments: Limited only by 200 line program length
MMI Variables for Storing Speeds, Distances and Loop Counts Entered by Operator: 50
Maximum Size of Messages Displayed by an MMI Prompt: 60 characters (80 for an MMI menu instruction)

Maximum Total Size of all MMI Prompt Messages: 1500 characters
Steps/revolution: 2000 to 50,800 (200 to 50,800 with Si-100 indexer)
Connectors: RJ11 for drives and PC/MMI, screw terminals for programmable inputs and outputs, accept 16 to 28 AWG wire
Programmable Inputs: Optically isolated, 2200 Ω internal impedance, 5 to 24 Vdc
Programmable Outputs: Optically isolated (photo darlington), 28 Vdc max, 100 mA max

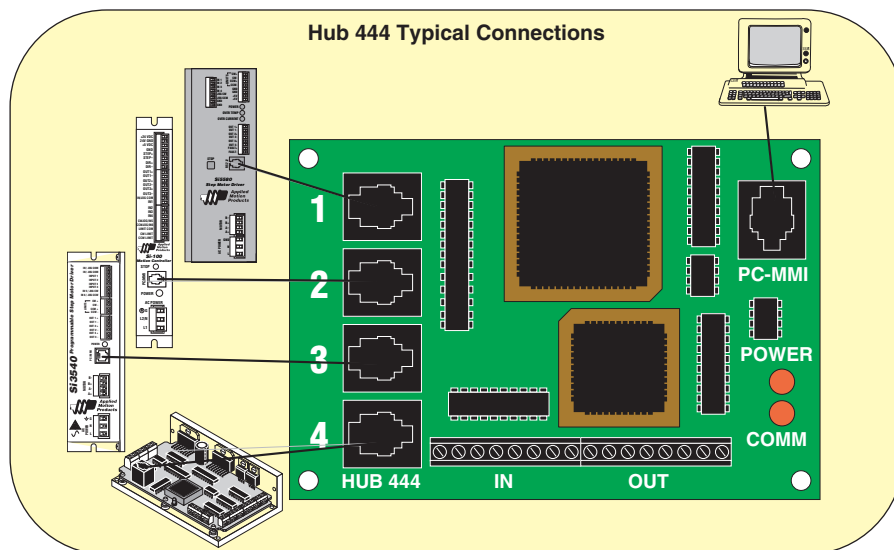
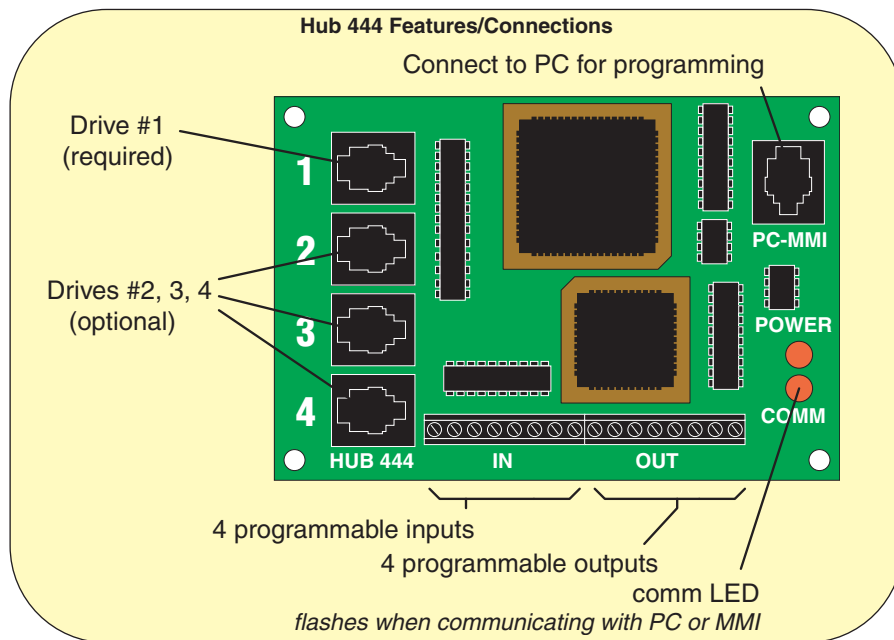

To Order (Specify Model Number)

AVAILABLE FOR FAST DELIVERY!

MODEL NO.	PRICE	DESCRIPTION
HUB 444 DIN RAIL	\$320	Multi-axis network hub with DIN rail mounting kit

Comes complete with software and cables.

Ordering Example: HUB 444, multi-axis network hub, \$320.



UNITED STATES

www.omega.com
1-800-TC-OMEGA
Stamford, CT.

CANADA

www.omega.ca
Laval(Quebec)
1-800-TC-OMEGA

GERMANY

www.omega.de
Deckenpfronn, Germany
0800-8266342

UNITED KINGDOM

www.omega.co.uk
Manchester, England
0800-488-488

FRANCE

www.omega.fr
Guyancourt, France
088-466-342

CZECH REPUBLIC

www.omegaeng.cz
Karviná, Czech Republic
596-311-899

BENELUX

www.omega.nl
Amstelveen, NL
0800-099-33-44



More than 100,000 Products Available!

• Temperature

Calibrators, Connectors, General Test and Measurement Instruments, Glass Bulb Thermometers, Handheld Instruments for Temperature Measurement, Ice Point References, Indicating Labels, Crayons, Cements and Lacquers, Infrared Temperature Measurement Instruments, Recorders Relative Humidity Measurement Instruments, RTD Probes, Elements and Assemblies, Temperature & Process Meters, Timers and Counters, Temperature and Process Controllers and Power Switching Devices, Thermistor Elements, Probes and Assemblies, Thermocouples Thermowells and Head and Well Assemblies, Transmitters, Wire

• Flow and Level

Air Velocity Indicators, Doppler Flowmeters, Level Measurement, Magnetic Flowmeters, Mass Flowmeters, Pitot Tubes, Pumps, Rotameters, Turbine and Paddle Wheel Flowmeters, Ultrasonic Flowmeters, Valves, Variable Area Flowmeters, Vortex Shedding Flowmeters

• pH and Conductivity

Conductivity Instrumentation, Dissolved Oxygen Instrumentation, Environmental Instrumentation, pH Electrodes and Instruments, Water and Soil Analysis Instrumentation

• Data Acquisition

Auto-Dialers and Alarm Monitoring Systems, Communication Products and Converters, Data Acquisition and Analysis Software, Data Loggers Plug-in Cards, Signal Conditioners, USB, RS232, RS485 and Parallel Port Data Acquisition Systems, Wireless Transmitters and Receivers

• Pressure, Strain and Force

Displacement Transducers, Dynamic Measurement Force Sensors, Instrumentation for Pressure and Strain Measurements, Load Cells, Pressure Gauges, Pressure Reference Section, Pressure Switches, Pressure Transducers, Proximity Transducers, Regulators, Strain Gages, Torque Transducers, Valves

• Heaters

Band Heaters, Cartridge Heaters, Circulation Heaters, Comfort Heaters, Controllers, Meters and Switching Devices, Flexible Heaters, General Test and Measurement Instruments, Heater Hook-up Wire, Heating Cable Systems, Immersion Heaters, Process Air and Duct, Heaters, Radiant Heaters, Strip Heaters, Tubular Heaters