

# OPERATOR INTERFACE

## DISPLAY MESSAGES, CHANGE MOTION PARAMETERS "ON THE FLY"



MMI-01, \$695, shown smaller than actual size.

MMI-01  
**\$695**



Complex, confusing items like baud rate, parity and cursor positioning are handled automatically by the software. On screen emulation of the MMI-01 by the Si™ Programmer software allows a potential user to try the MMI before purchasing one.

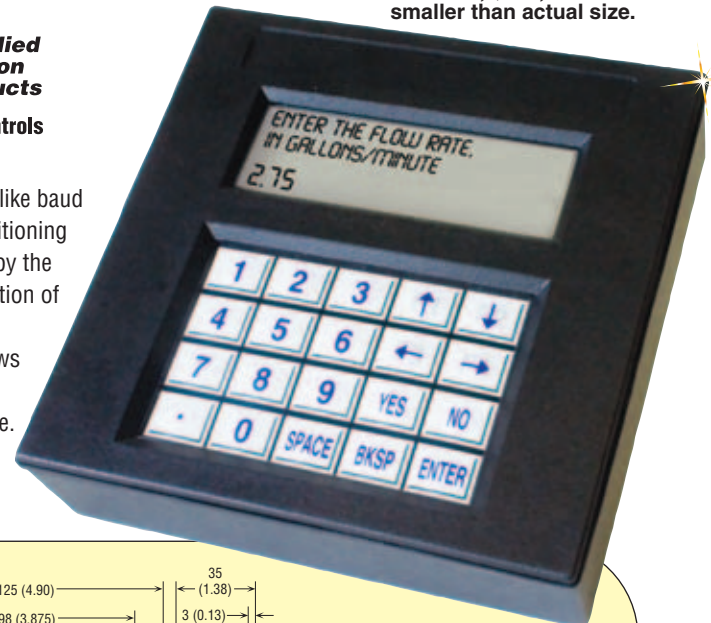

- Ideal Operator Interface for Si Programmable Drives
- Connects Directly to Programmable Drives Using the Standard Programming Cable—No Special Wiring Required
- Power is Supplied by the Drive—No Additional Power Supply Required
- Easy to Program Using Simple Indexer™ Programmer Software
- 4-Line, 20 Character/Line LCD Display
- 20 Key Keypad
- NEMA 4/12 (IP56/52) Rating (Dustproof and Drip Proof When Properly Mounted)
- Can be Surface Mounted or Flush Mounted [NEMA 4/12 (IP56/52) Rating for Flush Mounting Only]

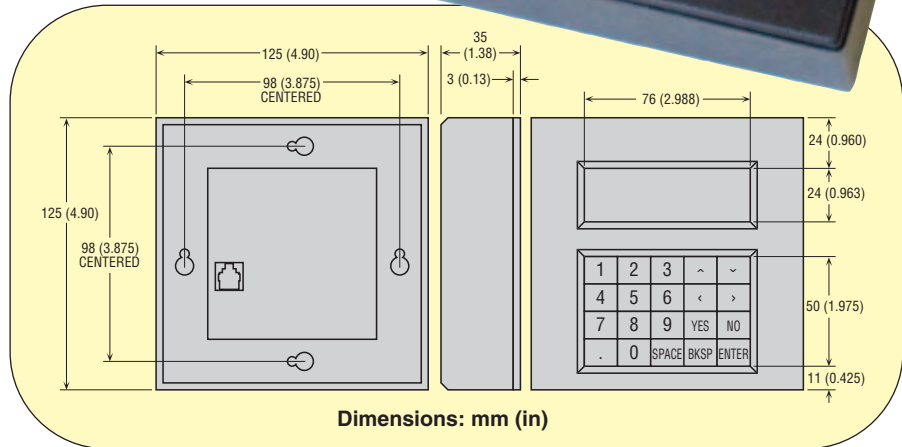

The MMI-01 is an easy-to-use, flexible device that allows an operator to enter move speeds, move distances or repeat loop counts. Messages can also be displayed and the program can be paused until the user presses a key, such as ENTER, YES or NO. Program branching can be accomplished based on the response of YES or NO. The MMI-01 is compact, easy to install and carries a NEMA 4/12 (IP56/52) rating (The 4 x 20 character display and 20 key membrane keypad are sealed). Connection to any of our "Si" or "i" indexer drives is accomplished by the standard programming cable that is supplied with every drive. This cable also supplies power to the MMI-01 so that no additional power supply or wiring is needed. Set-up and programming of the MMI-01 is fast and easy. Our programmable "Si" or "i" drives are furnished with Si™ Programmer software, which allows the user to easily program instructions for the terminal.

## PROGRAMMING

- Easy to Program Using Si™ Programmer Software, Running on Windows 3.1™ or Windows 95™
- Six Functions Are Available:
  - 1) Display a Message, Up to 60 Characters
  - 2) Display a Message and Pause Program Until Operator Presses ENTER Key
  - 3) Display a Message, Wait for Operator to Press YES or NO Key, Branch Program on YES
  - 4) Display Message, Allow Operator to Enter a Loop Count
  - 5) Display Message, Allow Operator to Enter a Speed
  - 6) Display Message, Allow Operator to Enter a Distance
- Speeds, Distances and Loop Counts Entered by the Operator Can be Stored in Any of Eight Nonvolatile Memory Locations for Use in Repeat Loops and Motor Moves

### To Order (Specify Model Number)

AVAILABLE FOR FAST DELIVERY!

| MODEL NO. | PRICE | DESCRIPTION        |
|-----------|-------|--------------------|
| MMI-01    | \$695 | Operator interface |

Ordering Example: MMI-01, operator interface, \$695.



#### UNITED STATES

[www.omega.com](http://www.omega.com)  
1-800-TC-OMEGA  
Stamford, CT.

#### CANADA

[www.omega.ca](http://www.omega.ca)  
Laval(Quebec)  
1-800-TC-OMEGA

#### GERMANY

[www.omega.de](http://www.omega.de)  
Deckenpfronn, Germany  
0800-8266342

#### UNITED KINGDOM

[www.omega.co.uk](http://www.omega.co.uk)  
Manchester, England  
0800-488-488

#### FRANCE

[www.omega.fr](http://www.omega.fr)  
Guyancourt, France  
088-466-342

#### CZECH REPUBLIC

[www.omegaeng.cz](http://www.omegaeng.cz)  
Karviná, Czech Republic  
596-311-899

#### BENELUX

[www.omega.nl](http://www.omega.nl)  
Amstelveen, NL  
0800-099-33-44



## More than 100,000 Products Available!

### • Temperature

Calibrators, Connectors, General Test and Measurement Instruments, Glass Bulb Thermometers, Handheld Instruments for Temperature Measurement, Ice Point References, Indicating Labels, Crayons, Cements and Lacquers, Infrared Temperature Measurement Instruments, Recorders Relative Humidity Measurement Instruments, RTD Probes, Elements and Assemblies, Temperature & Process Meters, Timers and Counters, Temperature and Process Controllers and Power Switching Devices, Thermistor Elements, Probes and Assemblies, Thermocouples Thermowells and Head and Well Assemblies, Transmitters, Wire

### • Flow and Level

Air Velocity Indicators, Doppler Flowmeters, Level Measurement, Magnetic Flowmeters, Mass Flowmeters, Pitot Tubes, Pumps, Rotameters, Turbine and Paddle Wheel Flowmeters, Ultrasonic Flowmeters, Valves, Variable Area Flowmeters, Vortex Shedding Flowmeters

### • pH and Conductivity

Conductivity Instrumentation, Dissolved Oxygen Instrumentation, Environmental Instrumentation, pH Electrodes and Instruments, Water and Soil Analysis Instrumentation

### • Data Acquisition

Auto-Dialers and Alarm Monitoring Systems, Communication Products and Converters, Data Acquisition and Analysis Software, Data Loggers Plug-in Cards, Signal Conditioners, USB, RS232, RS485 and Parallel Port Data Acquisition Systems, Wireless Transmitters and Receivers

### • Pressure, Strain and Force

Displacement Transducers, Dynamic Measurement Force Sensors, Instrumentation for Pressure and Strain Measurements, Load Cells, Pressure Gauges, Pressure Reference Section, Pressure Switches, Pressure Transducers, Proximity Transducers, Regulators, Strain Gages, Torque Transducers, Valves

### • Heaters

Band Heaters, Cartridge Heaters, Circulation Heaters, Comfort Heaters, Controllers, Meters and Switching Devices, Flexible Heaters, General Test and Measurement Instruments, Heater Hook-up Wire, Heating Cable Systems, Immersion Heaters, Process Air and Duct, Heaters, Radiant Heaters, Strip Heaters, Tubular Heaters