

# 110 KS/s 12-Bit Low-Cost A/D Boards

## OME-PCI-1002L/OME-PCI-1002H

**\$379**

Basic unit

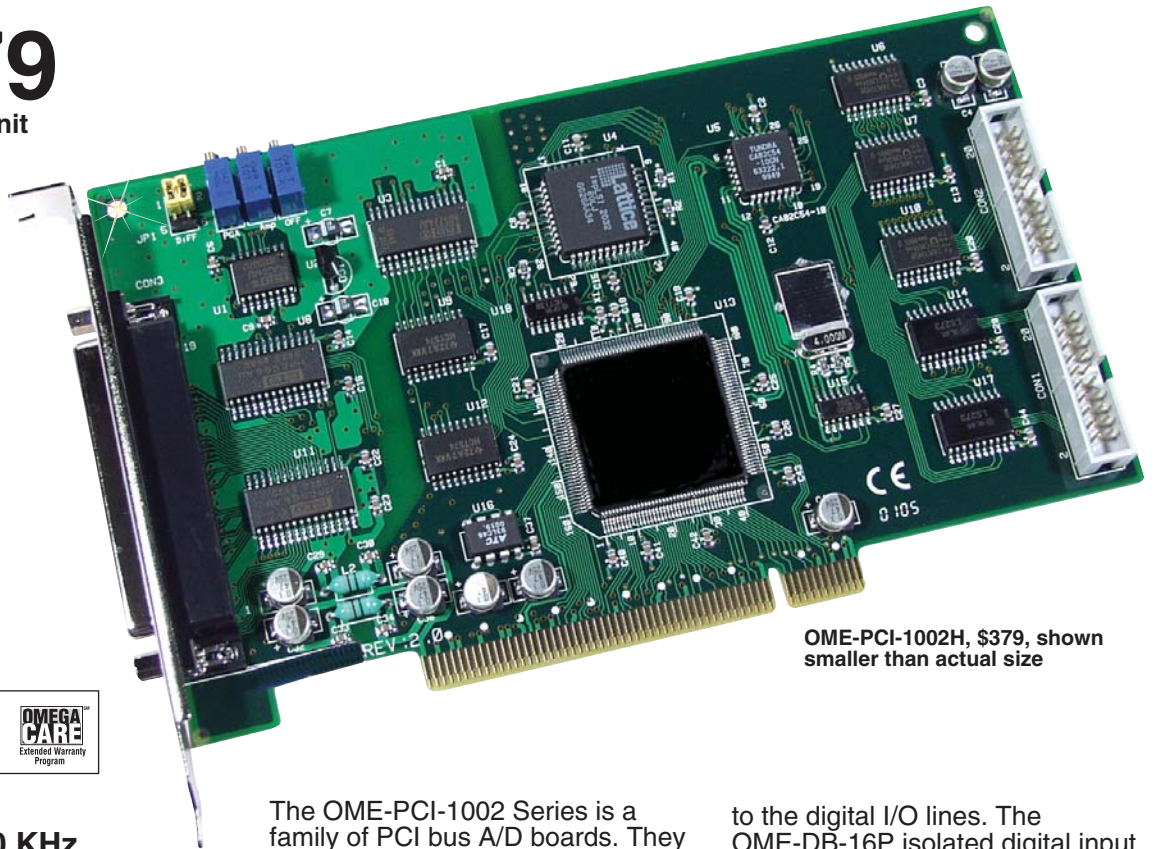

OME-PCI-1002H, \$379, shown smaller than actual size



- ✓ PCI Bus
- ✓ 12-Bit 110 KHz A/D Converter
- ✓ 32 Single-Ended/16 Differential Analog Inputs
- ✓ Sampling Rate:  
OME-PCI-1002L: 110KS/s  
OME-PCI-1002H: 40KS/s (Single Channel or Multiple Channels)
- ✓ Three Different External Triggers: Post-Trigger, Pre-Trigger, External Pacer Trigger
- ✓ 16 Digital Input and 16 Digital Output Channels
- ✓ OME-PCI-1002L: Programmable Low Gain: 1, 2, 4, 8
- ✓ OME-PCI-1002H: Programmable High Gain: 1, 10, 100, 1000
- ✓ Half-Size Board
- ✓ Includes Software Development Kit

The OME-PCI-1002 Series is a family of PCI bus A/D boards. They feature 110 KHz data acquisition under DOS and Windows. The boards provide 32 single-ended or 16 differential inputs, 16 digital input and 16 digital output channels.

The suffix "H" denotes a high-gain model and the suffix "L" denotes a low-gain model. The OME-PCI-1002 Series provides three flexible external trigger modes: post-trigger, pre-trigger, middle trigger.

### Software Development Kit

All boards are supplied with a standard software development kit for Windows 98/NT/2000/XP. The software kit includes DLL files for programming in C, C++, or other high-level languages, and OCX files for Visual Basic or Active X programming. DASyLab and LabVIEW drivers are also included.

The OME-PCI-1002 includes 16-channels of digital input and 16-channels of digital output. An OME-DB-8025 screw terminal panel can be used to connect

to the digital I/O lines. The OME-DB-16P isolated digital input board and OME-DB-16R relay board can be used to connect the digital I/O on the OME-PCI-1002 to real-world signals.

### OME-PCI-1002H Input Ranges (High Gain)

Gain	Range	Throughput
1	±5 V	40 K/s
10	±0.5 V	40 K/s
100	±0.05 V	10 K/s
1000	±0.005 V	1 K/s

### OME-PCI-1002L Input Ranges (Low Gain)

Gain	Range	Throughput
1	±5 V	110 K/s
2	±2.5 V	110 K/s
4	±1.25 V	110 K/s
8	±0.625 V	110 K/s

## Specifications

### ANALOG INPUT SPECIFICATIONS

#### Channels:

OME-PCI-1002H, OME-PCI-1002L:  
32 single-ended/16 differential

#### Resolution: 12-bits

#### Max Conversion Rate:

OME-PCI-1002H: 40 KS/s

OME-PCI-1002L: 110 KS/s

Input Impedance: 10,000 MΩ/6pF

Overvoltage Protection: ±35 V

Accuracy: 0.01% of reading ±1-bit

Linearity: ±1-bit

### DIGITAL I/O

Inputs: 16 channels; TTL levels

#### Input Low:

$V_{IL} = 0.8 \text{ V max}$

$I_{IL} = 4 \text{ mA}$

#### Input High:

$V_{IH} = 2 \text{ V min}$

$I_{IH} = -20 \text{ } \mu\text{A max}$



OME-DB-16P, \$99, shown smaller than actual size

Outputs: 16 channels; TTL levels

#### Output Low:

$V_{OL} = 0.33 \text{ V max}$

$I_{OL} = 4 \text{ mA max}$

#### Output High:

$V_{OH} = 3.83 \text{ V min}$

$I_{OH} = -400 \text{ } \mu\text{A max}$

### TIMER COUNTER

#### Internal Pacer Timer:

16-bit, 8 MHz input

#### External Pacer Timer:

16-bit, 8 MHz input

#### Machine Independent Timer:

16-bit, 8 MHz input

### GENERAL ENVIRONMENTAL

#### Operating Temperature:

0 to 50°C (32 to 122°F)

#### Storage Temperature:

-20 to 70°C (-4 to 158°F)

#### Humidity: 0 to 90% RH

non-condensing

#### Dimensions: 175 L x 105 mm H

(6.9 x 4.1")

#### Power Requirements:

5 V @ 350 mA (max)

OMEGACARE<sup>SM</sup> extended warranty program is available for models shown on this page. Ask your sales representative for full details when placing an order. OMEGACARE<sup>SM</sup> covers parts, labor and equivalent loaners.

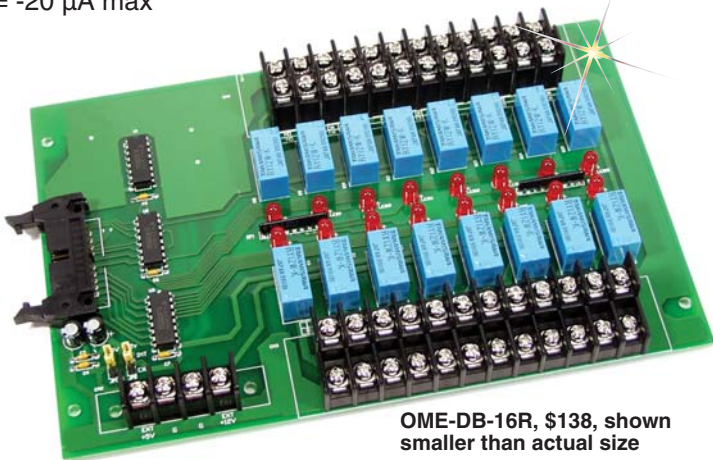

OME-DB-16R, \$138, shown smaller than actual size

**AVAILABLE FOR FAST DELIVERY!**

### To Order (Specify Model Number)

Model Number	Price	Description
OME-PCI-1002H	\$379	40 KS/s high gain, 12-bit analog and digital I/O board
OME-PCI-1002L	379	110 KS/s low gain, 12-bit analog and digital I/O board
OME-DB-1825/1	99	Screw terminal board for analog input channels with 1 m 37-pin D-Sub cable
OME-DB-1825/2	109	Screw terminal board for analog input channels with 2 m 37-pin D-Sub cable
OME-DB-8025	69	Screw terminal board for digital I/O, includes two 1 m 20-pin flat cable
OME-DB-16P	99	16-channel isolated digital input board, includes 1 m 20-pin flat cable
OME-DB-16R	149	16-channel SPDT relay board, includes 1 m 20-pin flat cables
OME-ADP-20/PCI	39	20-pin extender (extends the dual 20-pin digital I/O flat cable connectors on the board to the PC slot window), includes two 20-pin flat cables

Each OME-PCI-1002H and OME-PCI-1002L data acquisition board includes complete operator's manual on CD ROM and software development kit.

**Ordering Example:** OME-PCI-1002H, high-gain data acquisition board, OME-DB-8025, screw terminal board and OCW-1, OMEGACARE<sup>SM</sup> 1-year extended warranty for OME-PCI-1002H (adds 1 year to standard 1-year warranty), \$379 + 69 + 36 = \$484.



#### UNITED STATES

[www.omega.com](http://www.omega.com)  
1-800-TC-OMEGA  
Stamford, CT.

#### CANADA

[www.omega.ca](http://www.omega.ca)  
Laval(Quebec)  
1-800-TC-OMEGA

#### GERMANY

[www.omega.de](http://www.omega.de)  
Deckenpfronn, Germany  
0800-8266342

#### UNITED KINGDOM

[www.omega.co.uk](http://www.omega.co.uk)  
Manchester, England  
0800-488-488

#### FRANCE

[www.omega.fr](http://www.omega.fr)  
Guyancourt, France  
088-466-342

#### CZECH REPUBLIC

[www.omegaeng.cz](http://www.omegaeng.cz)  
Karviná, Czech Republic  
596-311-899

#### BENELUX

[www.omega.nl](http://www.omega.nl)  
Amstelveen, NL  
0800-099-33-44



## More than 100,000 Products Available!

### • Temperature

Calibrators, Connectors, General Test and Measurement Instruments, Glass Bulb Thermometers, Handheld Instruments for Temperature Measurement, Ice Point References, Indicating Labels, Crayons, Cements and Lacquers, Infrared Temperature Measurement Instruments, Recorders Relative Humidity Measurement Instruments, RTD Probes, Elements and Assemblies, Temperature & Process Meters, Timers and Counters, Temperature and Process Controllers and Power Switching Devices, Thermistor Elements, Probes and Assemblies, Thermocouples Thermowells and Head and Well Assemblies, Transmitters, Wire

### • Flow and Level

Air Velocity Indicators, Doppler Flowmeters, Level Measurement, Magnetic Flowmeters, Mass Flowmeters, Pitot Tubes, Pumps, Rotameters, Turbine and Paddle Wheel Flowmeters, Ultrasonic Flowmeters, Valves, Variable Area Flowmeters, Vortex Shedding Flowmeters

### • pH and Conductivity

Conductivity Instrumentation, Dissolved Oxygen Instrumentation, Environmental Instrumentation, pH Electrodes and Instruments, Water and Soil Analysis Instrumentation

### • Data Acquisition

Auto-Dialers and Alarm Monitoring Systems, Communication Products and Converters, Data Acquisition and Analysis Software, Data Loggers Plug-in Cards, Signal Conditioners, USB, RS232, RS485 and Parallel Port Data Acquisition Systems, Wireless Transmitters and Receivers

### • Pressure, Strain and Force

Displacement Transducers, Dynamic Measurement Force Sensors, Instrumentation for Pressure and Strain Measurements, Load Cells, Pressure Gauges, Pressure Reference Section, Pressure Switches, Pressure Transducers, Proximity Transducers, Regulators, Strain Gages, Torque Transducers, Valves

### • Heaters

Band Heaters, Cartridge Heaters, Circulation Heaters, Comfort Heaters, Controllers, Meters and Switching Devices, Flexible Heaters, General Test and Measurement Instruments, Heater Hook-up Wire, Heating Cable Systems, Immersion Heaters, Process Air and Duct, Heaters, Radiant Heaters, Strip Heaters, Tubular Heaters