



User's Guide

Shop on line at



omega.com

e-mail: info@omega.com

For latest product manuals

omegamanual.info

CN1001-TC

Programmable Digital
Thermocouple/Temperature Meter with
Time Proportional Control



OMEGAnet® On-Line Service www.omega.com	Internet e-mail info@omega.com
--	---

Servicing North America:

USA:
ISO 9001 Certified
One Omega Drive, P.O. Box 4047
Stamford CT 06907-0047
TEL: (203) 359-1660 FAX: (203) 359-7700
e-mail: info@omega.com

Canada:
976 Bergar
Laval (Quebec) H7L 5A1
TEL: (514) 856-6928 FAX: (514) 856-6886
e-mail: info@omega.ca

For immediate technical or application assistance:

USA and Canada: Sales Service: 1-800-826-6342 / 1-800-TC-OMEGA®
Customer Service: 1-800-622-2378 / 1-800-622-BEST®
Engineering Service: 1-800-872-9436 / 1-800-USA-WHEN®

Mexico and Latin American: TEL: (001)800-TC-OMEGA® FAX: (001) 203-359-7807
En Español: (001) 203-359-7803
e-mail: espanol@omega.com

Servicing Europe:

Czech Republic: Frystatska 184, 733 01 Karviná
TEL: +420 59 6311899 FAX: +420 59 6311114
e-mail: info@omegashop.cz

Germany/Austria: Daimlerstrasse 26, D-75392 Deckenpfronn, Germany
TEL: +49 7056 9398-0 FAX: +49 7056 9398-29
Toll Free in Germany: 0800 639 7678
e-mail: info@omega.de

United Kingdom: One Omega Drive
ISO 9002 Certified
River Bend Technology Centre
Northbank, Irlam Manchester M44 5BD United Kingdom
TEL: +44 161 777 6611 FAX: +44 161 777 6622
Toll Free in England: 0800 488 488
e-mail: sales@omega.co.uk

It is the policy of OMEGA to comply with all worldwide safety and EMC/EMI regulations that apply. OMEGA is constantly pursuing certification of its products to the European New Approach Directives. OMEGA will add the CE mark to every appropriate device upon certification.

The information contained in this document is believed to be correct, but OMEGA Engineering, Inc. accepts no liability for any errors it contains, and reserves the right to alter specifications without notice.

WARNING: These products are not designed for use in, and should not be used for, patient-connected applications.

This device is marked with the international caution symbol. It is important to read the Setup Guide before installing or commissioning this device as the guide contains important information relating to safety and EMC.



This device is marked with the international caution symbol. It is important to read the Setup Guide before installing or commissioning this device as the guide contains important information relating to safety and EMC.

TABLE OF CONTENTS

Section	Page
SEC 1	INTRODUCTION 1
1.1	Description 1
1.2	Standard Features 1
1.3	Optional Features 1
SEC 2	NOTES, WARNINGS and CAUTIONS 1
SEC 3	UNPACKING 2
SEC 4	SAFETY CONSIDERATIONS 3
SEC 5	PARTS OF THE METER 4
5.1	Front of the Meter 4
5.2	Rear of the Meter 8
SEC 6	SETUP 8
6.1	Conditions Requiring Disassembly 8
6.2	Disassembly 8
6.3	Rating/Product Label 8
6.4	Main Board Power Jumpers 8
6.5	Main Board Jumpers 9
6.6	Panel Mounting 11
SEC 7	SENSOR INPUT AND MAIN POWER CONNECTIONS 12
7.1	Sensor Input Connections 12
7.2	Main Power Connections 13
7.3	Analog and Relay Output Connections 14
SEC 8	INPUT TYPE (INPT) 17
SEC 9	DECIMAL POINT POSITION (DEC.P) 17
SEC 10	READING CONFIGURATION (“RD.CF”) 18
SEC 11	SETPOINT 1 CONFIGURATION (S1.CF) 18
SEC 12	SETPOINT 2 CONFIGURATION (S2.CF) 19
SEC 13A	SETPOINT 1 DEADBAND (S1.DB) 19
SEC 13B	CYCLE TIME (Time) 20
SEC 14	SETPOINT 2 DEADBAND (S2.DB) 20
SEC 15	OUTPUT CONFIGURATION (OT.CF) 21
15.1	To Enable/Disable the Analog Output 21
15.2	To Select Analog Output as Current or Voltage 21
15.3	To Select Analog Output or Proportional Control 22
SEC 16	PROPORTIONAL BAND (P.BND) 23
SEC 17	MANUAL RESET (M.RST) 24
SEC 18	OUTPUT SCALE AND OFFSET (OT.S.O) 25
SEC 19	COLD JUNCTION OFFSET CALIBRATION (C.J.OF) 27
SEC 20	LOCK OUT CONFIGURATION (LK.CF) 28
20.1	To Enable/Disable the Reset Button in the Run Mode 28
20.2	To Enable/Disable Setpoint Changes 28
20.3	To Enable Display’s Program Version 28
SEC 21	TUNING PROPORTIONAL CONTROLLER 29
SEC 22	DISPLAY MESSAGES 30
SEC 23	MENU CONFIGURATION 31

TABLE OF CONTENTS (Continued)

Section		Page
SEC 24	SETPOINT CONFIGURATION DISPLAYS	35
SEC 25	SPECIFICATIONS	36
SEC 26	FACTORY PRESET VALUES	40
SEC 27	CE APPROVALS INFORMATION	41

LIST OF FIGURES

Figure		Page
5-1	Front-Panel Illustration	4
5-2a	Connector Label AC Power	6
5-2b	Connector Label DC Power	6
6-1	Main Board Power Jumpers (W1, W2, W3)	9
6-2	Main Board Jumper Positions (6 S2 Pins)	9
6-3	Meter - Exploded View	11
6-4	Panel Cutout	11
7-1	Sensor Input Connection	12
7-2	Main Power Connections - AC	13
7-3	Main Power Connections - DC	14
7-4	Analog Output Connections	14
7-5	Relay Output Connections	15
7-6	Isolated Analog Output Connections	15
7-7	Isolated Analog Output Upper Board Installation	16
7-8	Transistor Output Connection	16
16-1	Controller Output	23
25-1	Meter Dimensions	39

LIST OF TABLES

Table		Page
5-1	Front-Panel Part Description	4
5-2	Rear Connector Description	7
6-1	Jumper Functions	10
7-1	AC Power Connections	13
22-1	Display Messages	30
23-1	Configuration Menu	31
23-2	Run Mode Displays	34
24-1	Setpoint Configuration Displays	35
26-1	Factory Preset Values	40

SECTION 1. INTRODUCTION

1.1 DESCRIPTION

The Programmable Thermocouple/Temperature Meter with Time Proportional is a value packed indicator/ controller. Four full digits allow for an accurate display of your temperature. Your meter may be a basic indicator or it may include analog output or dual relay output. Analog output is fully scalable and may be configured as a proportional controller, or to follow your display. Dual 5 amp, form C relays control critical processes. Front panel peak detection and memory is also standard. A mechanical lockout has been included to guard against unauthorized changes.

1.2 STANDARD FEATURES

The following is a list of features:

- * 4-digit red 14 segment LED display
- * NEMA 4/Type 4 Front Bezel
- * ± 0.5 °C accuracy
- * J, K, DIN J or T thermocouple types
- * Peak detection and memory
- * Non-volatile memory-no battery backup
- * 115 or 230 V ac 50/60 Hz power supply

1.3 OPTIONAL FEATURES

- * Dual 5 amp, form C relay outputs
- * Scalable analog output
- * Proportional control
- * Front-panel deviation correction
- * Easy setup for proportional control

SECTION 2. NOTES, WARNINGS and CAUTIONS

Information that is especially important to note is identified by three labels:

- **NOTE**
- **WARNING**
- **CAUTION**
- **IMPORTANT**



NOTE: provides you with information that is important to successfully setup and use the Programmable Digital Meter.



CAUTION or WARNING: tells you about the risk of electric shock.



CAUTION, WARNING or IMPORTANT: tells you of circumstances or practices that can affect the meter's functionality and must refer to accompanying documents.

SECTION 3. UNPACKING

Remove the Packing List and verify that all equipment has been received. If there are any questions about the shipment, use the phone numbers listed to contact the Customer Service Department nearest you.

Upon receipt of shipment, inspect the container and equipment for any signs of damage. Take particular note of any evidence of rough handling in transit. Immediately report any damage to the shipping agent.

 *The carrier will not honor any claims unless all shipping material is saved for their examination. After examining and removing contents, save packing material and carton in the event reshipment is necessary.*

Verify that you receive the following items in the shipping box:

QTY	DESCRIPTION
1	Programmable indicator/controller with all applicable connectors attached.
1	Owner's Manual
1	Set Mounting brackets

 *If you ordered any of the available options (except the "BL" blank Lens option), they will be shipped in a separate container to avoid any damage to your indicator/controller.*

SECTION 4. SAFETY CONSIDERATIONS



This device is marked with the international Caution symbol. It is important to read this manual before installing or commissioning this device as it contains important information relating to Safety and EMC (Electromagnetic Compatibility).

Unpacking & Inspection



Unpack the instrument and inspect for obvious shipping damage. Do not attempt to operate the unit if damage is found.

This instrument is a **panel mount** device protected in accordance with EN 61010-1:2001, electrical safety requirements for electrical equipment for measurement, control and laboratory. Installation of this instrument should be done by qualified personnel. In order to ensure safe operation, the following instructions should be followed.

This instrument has no power-on switch. An external switch or circuit-breaker shall be included in the building installation as a disconnecting device. It shall be marked to indicate this function, and it shall be in close proximity to the equipment within easy reach of the operator. The switch or circuit-breaker shall not interrupt the Protective Conductor (Earth wire), and it shall meet the relevant requirements of IEC 947-1 and IEC 947-3 (International Electrotechnical Commission). The switch shall not be incorporated in the mains supply cord.

Furthermore, to provide protection against excessive energy being drawn from the mains supply in case of a fault in the equipment, an overcurrent protection device shall be installed.



- The **Protective Conductor** must be connected for safety reasons. Check that the power cable has the proper Earth wire, and it is properly connected. It is not safe to operate this unit without the Protective Conductor Terminal connected.



- Do not exceed voltage rating on the label located on the top of the instrument housing.
- Always disconnect power before changing signal and power connections.
- Do not use this instrument on a work bench without its case for safety reasons.
- Do not operate this instrument in flammable or explosive atmospheres.
- Do not expose this instrument to rain or moisture.
- Unit mounting should allow for adequate ventilation to ensure instrument does not exceed operating temperature rating.
- Use electrical wires with adequate size to handle mechanical strain and power requirements. Install without exposing bare wire outside the connector to minimize electrical shock hazards.

EMC Considerations

- Whenever EMC is an issue, always use shielded cables.
- Never run signal and power wires in the same conduit.
- Use signal wire connections with twisted-pair cables.
- Install Ferrite Bead(s) on signal wires close to the instrument if EMC problems persist.

SECTION 5. PARTS OF THE METER

5.1 FRONT OF THE METER

Figure 5-1 shows each part of the front of the meter. Table 5-1 on the next page gives a brief description of each part.

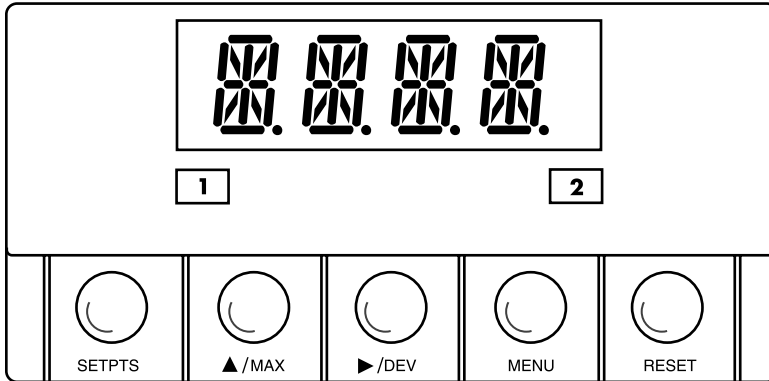

Figure 5-1. Front-Panel Illustration

- 1 - Setpoint 1 Status
- 2 - Setpoint 2 Status

Table 5-1. Front-Panel Part Description

ITEM	DESCRIPTION
1	<p>- 1.9.9.9. or 9.9.9.9. 4-digit 14 segment, 0.54" high LED display with programmable decimal point.</p>
2	<p>SETPOINT LED These LEDs labeled 1 and 2 display the status of setpoints 1 and 2.</p>
3	<p>SETPTS BUTTON This button functions only in the run mode. When the meter is in the run mode, press this button to sequentially recall the previous setpoint settings. After using the ▲/MAX and ▶/DEV buttons to alter these settings as desired, press the SETPTS button to store these new values.</p> <p>Unless you press the SETPTS button within 20 seconds to store your input, the meter will scroll to setpoint 2 and retain the last value stored.</p> <p><i>If the dual relay option is not installed, pressing the SETPTS button will display "V.-03" which is the meter's software version.</i></p>

Note

Table 5-1. Front-Panel Part Description

ITEM	DESCRIPTION
4	<p>▲/MAX BUTTON</p> <p>During the run mode, press the ▲/MAX button to recall the PEAK reading since the last press of the RESET button. To return to the current readings without resetting the PEAK reading, press the ▲/MAX button. To reset the PEAK reading, press the RESET button.</p> <p>During the configuration mode, use the ▲/MAX button to change the values of the flashing digit shown on the display and/or toggle between menu choices, such as “R.1=F” or “R.1=C”.</p> <p>When configuring your setpoint values, press the ▲/MAX button to increment the flashing digit from 0 to 9 by 1's.</p>
5	<p>▶/DEV BUTTON</p> <p>During the run mode press the ▶/DEV button to display the deviation from setpoint 1.</p> <p>When configuring your setpoint values, press the ▶/DEV button to scroll to the next digit.</p>
6	<p>MENU BUTTON</p> <p>In the run mode, press the MENU button to terminate the current measuring process and enter you into the configuration mode. (Note: only if you have installed the lockout jumpers on the main board.)</p> <p>In the configuration mode, press the MENU button to store changes in the non-volatile memory and then advance you to the next menu item.</p>
7	<p>RESET BUTTON</p> <p>In the run mode, if you hard reset (press the MENU button followed by the RESET button) or power off/on the meter, it shows “RST”, followed by “T/C”.</p> <p>In the run mode, press the RESET button to reset the setpoints. The meter shows “SP.RS” and returns to the run mode.</p> <p>In the configuration mode, press the RESET button once to review the previous menu. Press the RESET button twice to perform a hard reset and return to the run mode.</p> <p>In the peak mode, press the RESET button to reset peak value. The meter shows “PK.RS” and return to the run mode.</p> <p><i>When in setpoint or configuration mode, if the meter shows 9999 or -1999 with all flashing digits, the value has overflowed. Press the ▲/MAX button to start a new value.</i></p>

Note 

Table 5-2. Rear Connector Description

CONNECTOR	DESCRIPTION		
TB1-1	Setpoint 1: Normally open (N.O.1) connection		
TB1-2	Setpoint 1: Normally closed (N.C.1) connection		
TB1-3	Setpoint 1: Common (COM1) connection		
TB1-4	Setpoint 2: Normally open (N.O.2) connection		
TB1-5	Setpoint 2: Normally closed (N.C.2) connection		
TB1-6	Setpoint 2: Common (COM2) connection		
TB1-7	ac line connection (no connections on dc-powered units)		
TB1-8	ac neutral connection (+ Input on dc-powered units)		
TB1-9	ac earth ground (dc-power return on dc-powered units)		
TB1-10	Analog voltage output		
TB1-11	Analog current output		
TB1-12	Analog return		
Version 1*	(See Figure 6-2)	Version 2* (See Figure 6-2)	
TB3-A	+TC Input	TB4-B	+TC Input
TB3-B	-TC Input	TB4-C	-TC Input
TB5-1	Isolated Analog Voltage Output		
TB5-2	Isolated Analog Current Output		
TB5-3	Isolated Analog Output Return		
J1 (1-2)	Transistor Logic Output (Positive)		
J1 (1-2)	Transistor Logic Output (Ground)		

SECTION 6. SETUP

6.1 CONDITIONS REQUIRING DISASSEMBLY

You may need to open up the meter for one of the following reasons:

- To check or change the 115 or 230 Vac power jumpers.
- To install or remove jumpers on the main board.

6.2 DISASSEMBLY



Important: *Disconnect the power supply before proceeding.*

To remove and access the main board, follow these steps:

- Disconnect the main power from the meter.
- Remove the back case cover.
- Lift the back of the main board upwards and it slide out of the case.



Caution: The meter has no power-on switch, so it will be in operation as soon you apply power.

If you power off/on the meter, or perform a hard reset (press the **RESET** button twice), the meter shows “**RST**”, followed by “**TC**”.

6.3 RATING/PRODUCT LABEL

This label is located on top of the meter housing.

6.4 MAIN BOARD POWER JUMPERS (refer to Figures 6-1 and 6-2)



Important: If you want to change the Factory preset jumpers, do the following steps; otherwise go to section 6.6.



Important: *Disconnect the power from the unit before proceeding.*

1. Remove the main board from the case. Refer to Section 6.2.
2. Locate the solder jumpers W1, W2, and W3 (located near the edge of the main board alongside the transformer).
3. If your power requirement is **115 V ac**, solder jumpers **W1** and **W3** should be wired, but jumper **W2** should not. If your power requirement is **230 V ac**, solder jumper **W2** should be wired, but jumpers **W1** and **W3** should not.

6.4 MAIN BOARD POWER JUMPERS (Continued)

Figure 6-1 shows the W1 through W3 jumpers on the main board.

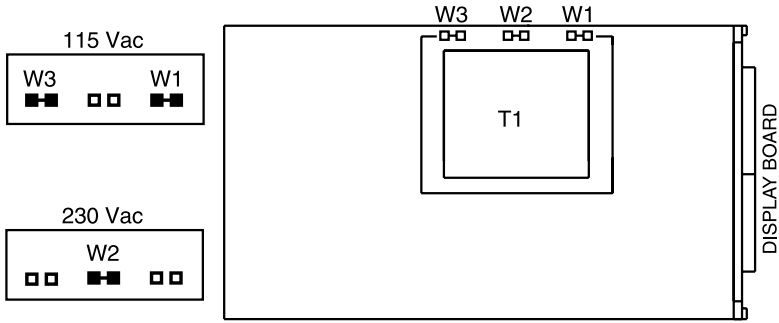

Figure 6-1. Main Board Power Jumpers (W1, W2, W3)

6.5 MAIN BOARD JUMPERS

Figure 6-2 Main board jumpers and Version #1 and Version #2 connectors.

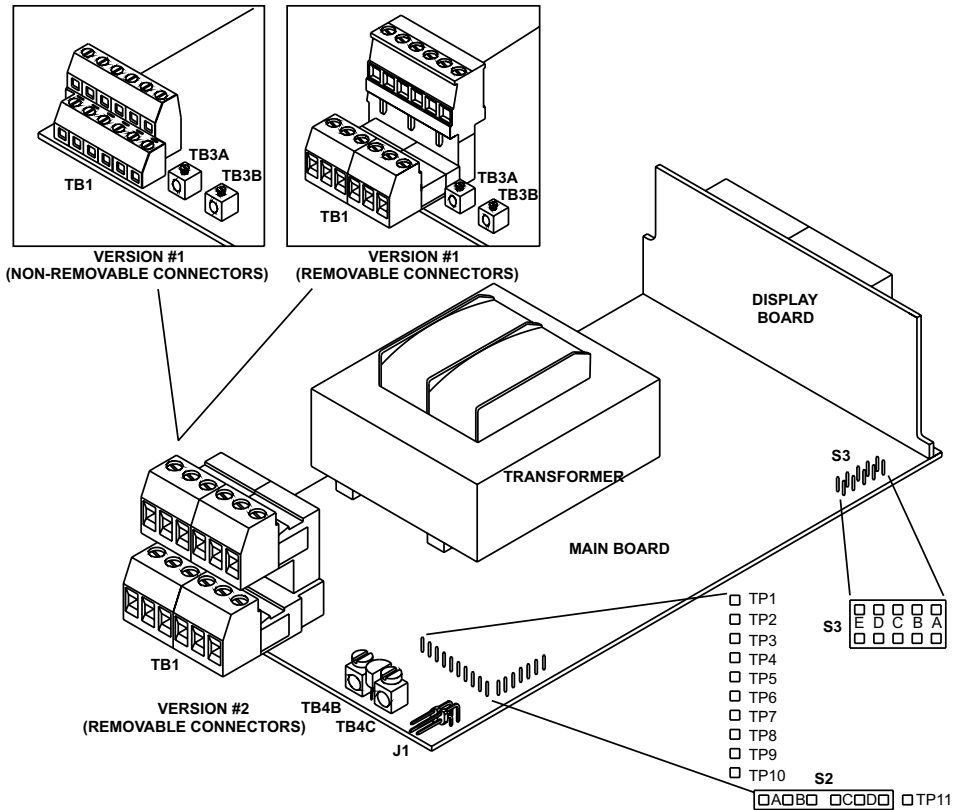

Figure 6-2. Main Board Jumper Positions

6.5 MAIN BOARD JUMPERS (Continued)

S2 jumpers are used for sensor break indications (refer to Table 6-1).

S3 jumpers are used for the following (refer to Table 6-1):

- * To enable or disable the front panel push-buttons
- * To allow for an extremely low resistance load for analog output
- * To disable the **MENU** button
- * To perform calibration procedure

Test pins TP1 - TP11 are for testing purposes. Do not use as reading errors may result.

Table 6-1. Jumper Functions

JUMPER	DESCRIPTION
S2-A	Install for negative sensor break (i.e., refrigeration).
S2-B	Install for positive sensor break (i.e., heating).
S2-C	Removed. Not used.
S2-D	Removed. Not Used.
S3-A	Install to enable front panel push-buttons. Remove to disable all front panel push-buttons
S3-B	Removed. Install for meter calibration.
S3-C	Normally removed. Install for analog voltage output when load has less than 1 K Ω impedance. Care should be taken when installing this jumper.
S3-D	Removed. Not used.
S3-E	If installed without S3-B, the MENU button locks out.
S4-A	Removed. Not used. (May not be present on all meters).

6.6 PANEL MOUNTING

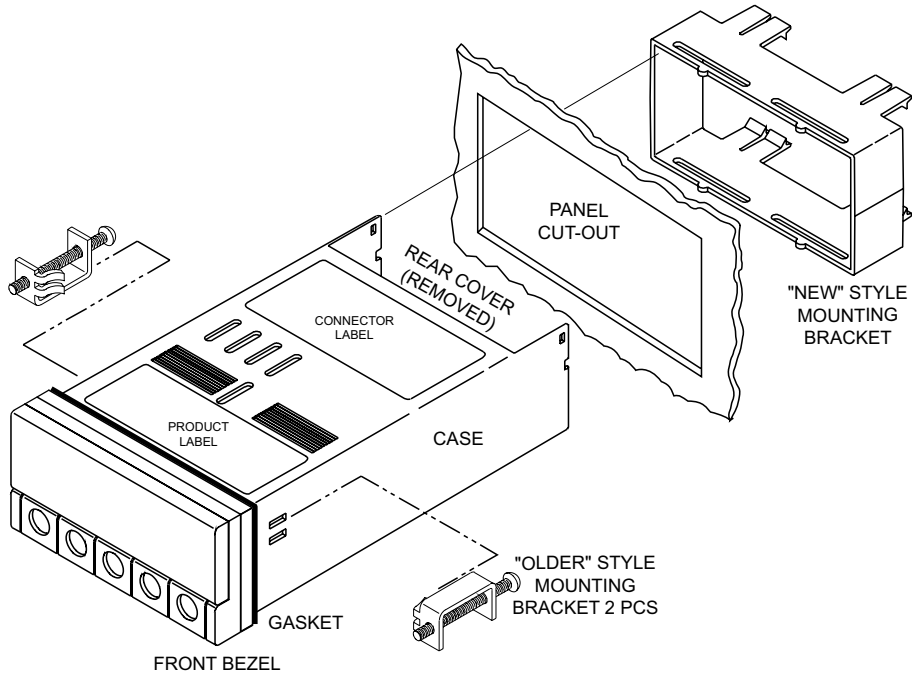
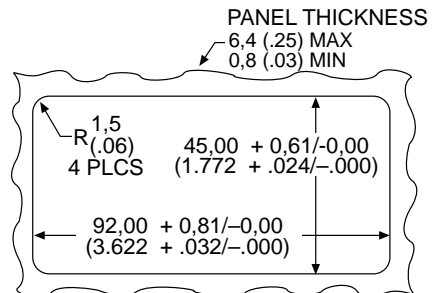

Figure 6-3. Meter - Exploded View

1. Cut a hole in your panel, as shown in Figure 6-3. For specific dimensions refer to Figure 6-4.
2. Insert the meter into the hole. Be sure the front bezel gasket is flush to the panel.
3. Slide on mounting bracket to secure.
4. Proceed to Section 7 to connect your sensor input and main power.



NOTE: Dimensions in Millimeters (Inches)

Figure 6-4 Panel Cutout

SECTION 7. SENSOR INPUT/ MAIN POWER CONNECTIONS

7.1 SENSOR INPUT CONNECTIONS

Figure 7-1 describes how to connect your sensor.

Note *The different versions are described in figure 6-2.*

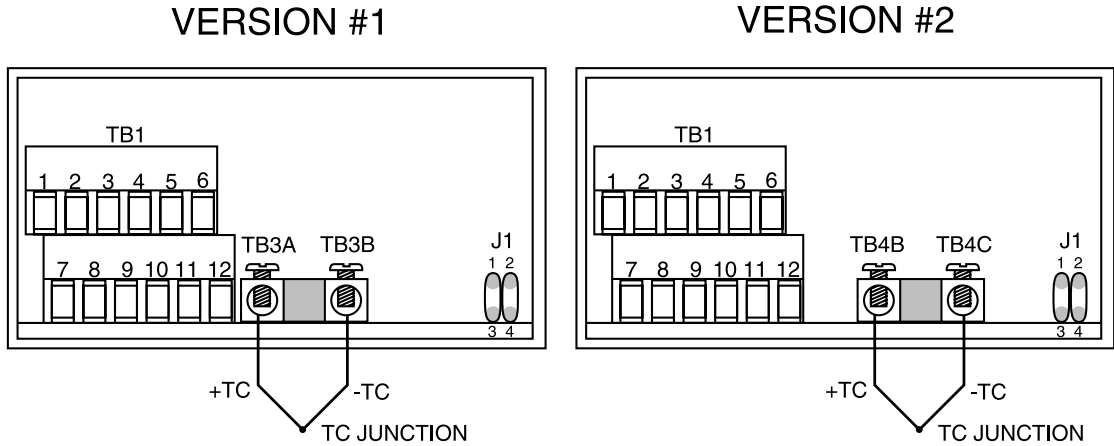

Figure 7-1. Sensor Input Connection

7.2 MAIN POWER CONNECTIONS

Figure 7-2 shows the proper AC power main power connections.



WARNING: Do not connect ac power to your meter until you have completed all input and output connections. Failure to do so may result in injury!

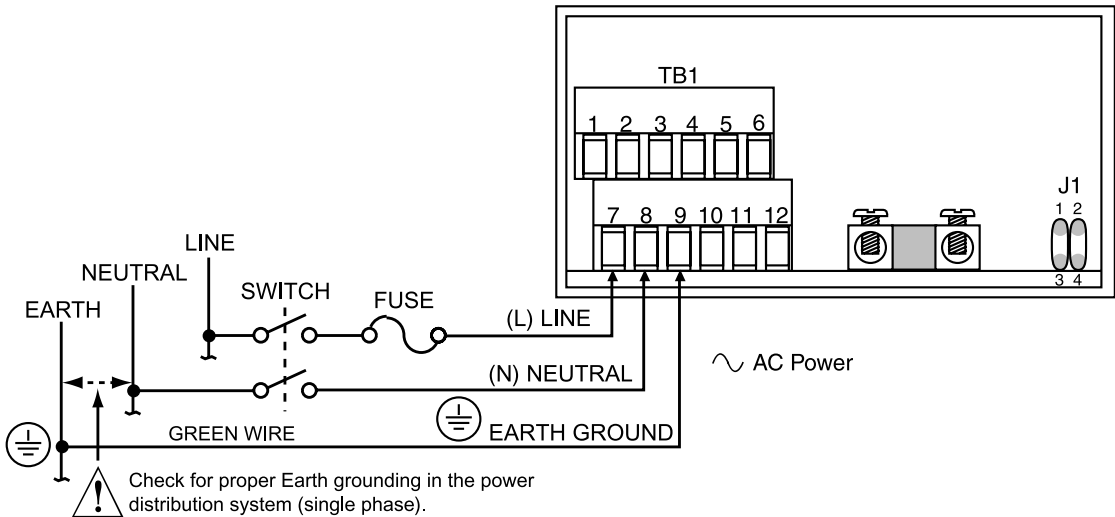

Figure 7-2. Main Power Connections -AC

Table 7-1 shows the wire color and respective terminal connections for both USA and Europe.

Table 7-1. ac-Power Connections

TB1	AC POWER	WIRE COLORS	
		EUROPE	USA
7	~ ac Line	Brown	Black
8	~ ac Neutral	Blue	White
9	~ ac Earth	Green/Yellow	Green

7.2 MAIN POWER CONNECTIONS (Continued)

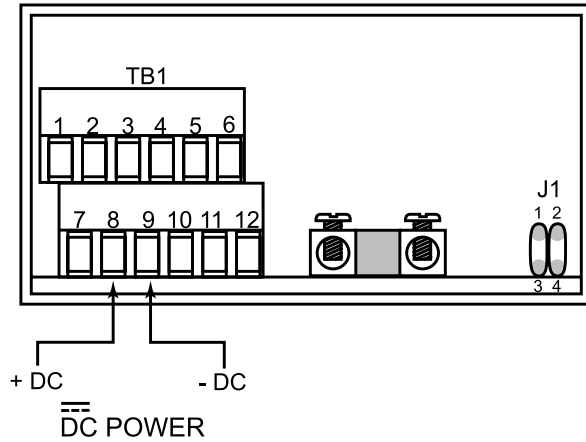

Figure 7-3. Main Power Connections - DC

7.3 RELAY AND ANALOG OUTPUT CONNECTIONS

If you have purchased a meter with dual or analog relay output, refer to the following drawings for output connections.

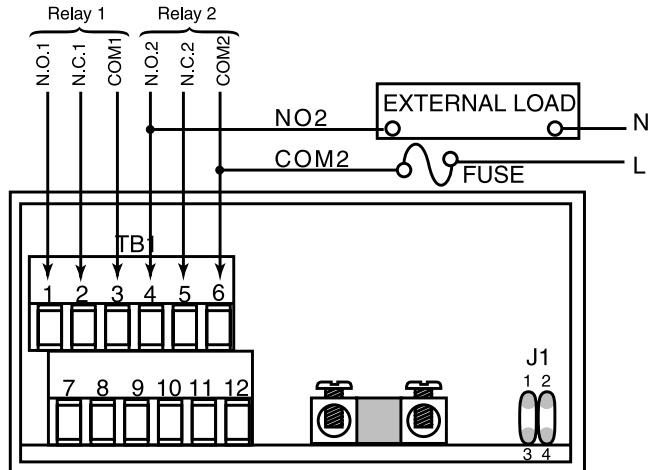

Figure 7-4. Relay Output Connections

7.3 RELAY AND ANALOG OUTPUT CONNECTIONS (Continued)

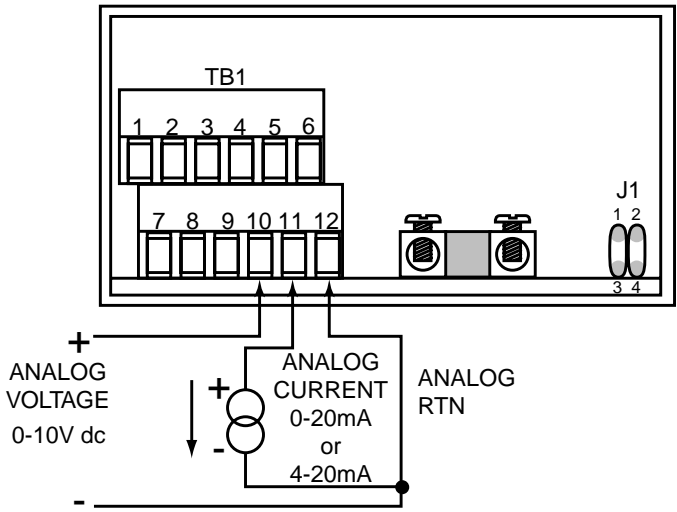

Figure 7-5. Analog Output Connections

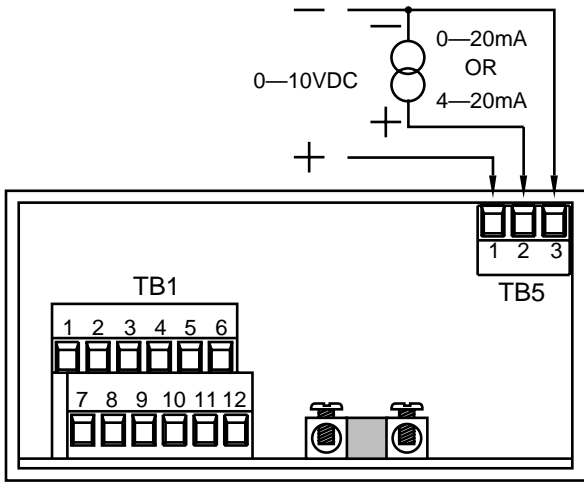

Figure 7-6. Isolated Analog Output Connections.

7.3 RELAY AND ANALOG OUTPUT CONNECTIONS (Continued)

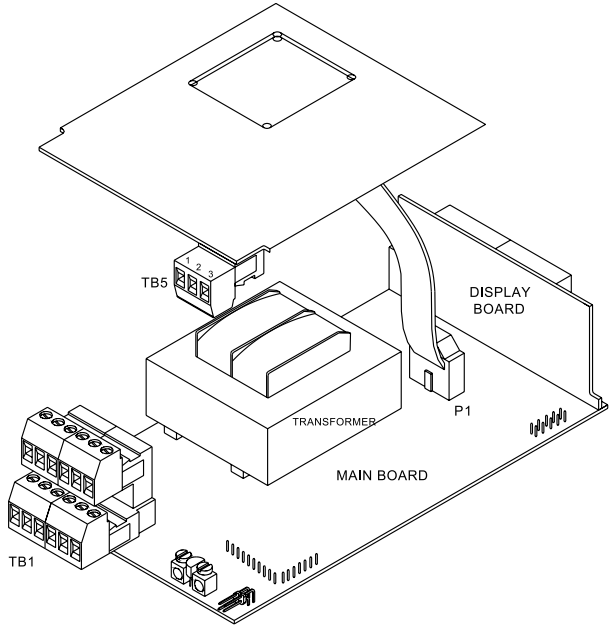

Figure 7-7. Isolated Analog Output Upper Board Installation

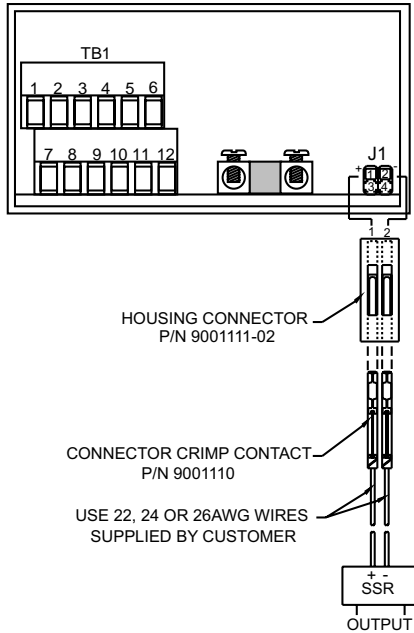

Figure 7-8. Transistor Output Connection

SECTION 8. INPUT TYPE (INPT)

Note Refer to Table 23-1 for a summary list of menu configuration.

To select your appropriate input type signal.

1. Press the **MENU** button until the meter shows “**INPT**”.
2. Press the **▶/DEV** button. The meter shows one of the following:
 - * **J.TC** - Iron vs. Constantan (NIST)
 - * **K.TC** - Nickel-Chromium vs. Nickel-Aluminum (NIST)
 - * **DJ.TC** - Iron vs. Copper (DIN)
 - * **T.TC** - Copper vs. Copper-Nickel
3. Press the **▲/MAX** button to scroll through available choices.
4. Press the **MENU** button to store your choices. The meter momentarily shows “**STRD**”, followed by “**DEC.P**” (Decimal point).

Note You may need to perform cold junction offset correction anytime you use a new type of thermocouple (refer to section 19).

SECTION 9. DECIMAL POINT POSITION (DEC.P)

Note Refer to Table 23-1 for a summary list of menu configuration.

To select a decimal point display position.

1. Press the **MENU** button until the meter shows “**DEC.P**”.
2. Press the **▶/DEV** button. The meter shows one of the following:
 - * **FFFF.**
 - * **FFF.F**
3. Press the **▲/MAX** button to scroll between choices.
4. Press the **MENU** button to store your choices. The meter momentarily shows “**STRD**”, followed by “**RD.CF**” (Reading Configuration).

Note *When you change the decimal position the meter adjusts setpoints, deadbands, proportional band, and manual reset values. These adjustments are made according to the new decimal point. If one or more of these values overflow, the meter flashes “ER2” when you store a new decimal point position value.*

AUTOMATIC DECIMAL POINT ADJUST

If you select 0.1 degree resolution the decimal point automatically adjusts itself to 1 degree if the temperature reading is above 999.9 or below -199.9.

SECTION 10. READING CONFIGURATION ("RD.CF")

To determine if your meter shows in °F (Fahrenheit) or °C (Celsius).

1. Press the **MENU** button until the meter shows "**RD.CF**".
2. Press the **▶/DEV** button. The meter shows one of the following:
 - * "R.1=F" (°F)
 - * "R.1=C" (°C)
3. Press the **▲/MAX** button to toggle between choices.
4. Press the **MENU** button to store your selection. The meter momentarily shows "**STRD**", followed by "**S1.CF**" (Setpoint 1 Configuration).

SECTION 11. SETPOINT 1 CONFIGURATION (S1.CF)

Setpoint 1 is not active unless your meter has dual relay output capabilities. The LED's will display whether the (S1.CF) is active or not. You may use Setpoint 1 Configuration (S1.CF) for the following:

- * To set the setpoint's active band above or below your chosen value
 - * To select whether the setpoint operation is latched or unlatched
 - * To select On/Off or Time Proportional Control
1. Press the **MENU** button until the meter shows "**S1.CF**".
 2. Press the **▶/DEV** button. The meter shows one of the following:
 - * "**S.1=A**" (**Active above the setpoint**) (**Factory default**)
 - * "S.1=B" (Active below the setpoint)
 3. Press the **▲/MAX** button to toggle between choices.
 4. Press the **▶/DEV** button again. The meter shows one of the following:
 - * "S.2=L" Setpoint 1 to be latched
 - * "**S.2=U**" (**Setpoint 1 to be unlatched**) (**Factory default**)
 5. Press the **▲/MAX** button to toggle between choices.
 6. Press the **▶/DEV** button. One of the following appears:
 - * "**S.3=O**" (**Setpoint 1 On/Off control**) (**Factory default**)
 - * "S.3=P" Setpoint 1 on Time Proportional Control
 7. Press the **▲/MAX** button to toggle between available selections.
 8. If you select "**S.3=O**" (factory default), press the **MENU** button to store. "**STRD**" momentarily appears, followed by "**S2.CF**" (Setpoint 2 Configuration). If you select "**S.3=O**" and press the **▶/DEV** button, the meter returns to **S.1** option.
If you select "**S.3=P**", press the **▶/DEV** button. One of the following appears:
 - * "S.4=R" (reverse acting, i.e., for heating)
 - * "S.4=D" (direct acting, i.e., for refrigeration)
 9. Press the **▲/MAX** button to toggle between available selections.
 10. Press the **▶/DEV** button. One of the following appears:
 - * "S.5=S" (slow proportional control, cycle time from 5 to 199 sec)
 - * "S.5=F" (fast proportional control, cycle time from 0.1 to 4.9 sec)
 11. Press the **▲/MAX** button to toggle between available selections.

Note

Transistor logic out is always enabled for either On/Off or Time Proportional control modes. Relay #1 is enable for On/Off control and for slow Time Proportional control ("S.5=S") modes. Relay #1 is disabled if "S.5=F" (fast mode).

SECTION 12. SETPOINT 2 CONFIGURATION (S2.CF)

Setpoint 2 Configuration (S2.CF) is not active unless your meter has dual relay output capabilities. The LED's will display whether the (S2.CF) is active or not. You may use Setpoint 2 Configuration (S2.CF) for the following:

- * To set the setpoint's active band above or below your chosen value
 - * To select whether the setpoint operation is latched or unlatched
1. Press the **MENU** button until the meter shows "**S2.CF**".
 2. Press the **▶/DEV** button. The meter shows one of the following:
 - * "**S.1=A**" (**Active above the setpoint**) (**Factory default**)
 - * "**S.1=B**" (Active below the setpoint)
 3. Press the **▲/MAX** button to toggle between choices.
 4. Press the **▶/DEV** button again. The meter shows one of the following:
 - * "**S.2=L**" Setpoint 1 to be latched
 - * "**S.2=U**" **Setpoint 1 to be unlatched (Factory default)**
 5. Press the **▲/MAX** button to toggle between choices.
 6. Press the **MENU** button to store your choice(s). The meter momentarily shows "**STRD**", followed by "**S1.DB**" (Setpoint 1 Deadband) or "**TIME**" (Cycle Time).

SECTION 13A. SETPOINT 1 DEADBAND (S1.DB)

Setpoint 1 Deadband (S1.DB) is not active unless your meter has dual relay output capabilities. The LED's will display whether the (S1.DB) is active or not. If you have selected "**S.3-0**" in setpoint 1 configuration ("**S1.CF**" - refer to Section 11) you may set the deadband (hysteresis) of Setpoint 1; follow these steps:

1. Press the **MENU** button until the meter shows "**S1.DB**".
2. Press the **▶/DEV** button. The meter shows the last previously stored 4-digit number (0000 through 9999) with flashing 4th digit.
3. Press the **▲/MAX** button to change the value of the flashing digit. If you continue to press the **▲/MAX** button, the flashing digit's value continues to change.
4. Press the **▶/DEV** button to scroll to the next digit.
5. Press the **MENU** button to store value. The meter momentarily shows "**STRD**", followed by "**S2.DB**" (Setpoint 2 Deadband)

SECTION 13B. CYCLE TIME (“TIME”)

If you have select “**S.3=P**” in Setpoint 1 Configuration (“**S1.CF**” refer to Section 11), you may specify a cycle time for the time proportional outputs.

1. Press the **MENU** button until “**TIME**” appears.
2. Press the **▶/DEV** button. The last previously stored value appears as follows:
If you have selected “**S.5=S**” in “**S1.CF**”, the third digit will flash and you may enter maximum/minimum values from 0005. through 0199. seconds (unit of measure is second in this mode).

Note *If you have selected “**S.5=S**” the Transistor and Relay 1 outputs are both enabled.*

or

If you have selected “**S.5=F**” in “**S1.CF**”, the second digit will flash and you may enter maximum/minimum values from 000.1 through 004.9 seconds (unit of measure is 0.1 second in this mode).

Note *If you have selected “**S.5=F**” only the Transistor output is enabled.*

3. Press the **▲/MAX** button to change the value of the flashing digit. If you continue to press the **▲/MAX** button, the flashing digit's value continues to change.
4. Press the **▶/DEV** button to scroll to the next digit.
5. Press the **MENU** button to store your selection. The meter momentarily shows “**STRD**”, followed by “**S2.DB**” (Setpoint 2 Deadband)

SECTION 14. SETPOINT 2 DEADBAND (S2.DB)

Refer to Table 23-1 for a summary list of menu configuration.

Setpoint 2 Deadband (**S2.DB**) is not active unless your meter has dual relay output capabilities. The LED's will display whether the (**S2.DB**) is active or not. To set the deadband (hysteresis) of Setpoint 2, follow these steps:

1. Press the **MENU** button until the meter shows “**S2.DB**”.
2. Press the **▶/DEV** button. The meter shows the last previously stored 4-digit number (0000 through 9999) with flashing 4th digit.
3. Press the **▲/MAX** button to change the value of the flashing digit.
If you continue to press the **▲/MAX** button, the flashing digit's value continues to change.
4. Press the **▶/DEV** button to scroll to the next digit.
5. Press the **MENU** button to store your selection. “**STRD**” momentarily displays, followed by cold junction offset if you have a standard meter (refer to Section 19) or “**OT.CF**” (Output Configuration) if you have analog output capabilities (refer to Section 15).

SECTION 15. OUTPUT CONFIGURATION (OT.CF)

Output Configuration is not active unless your meter has analog output capabilities. The menu will display whether analog output is present or not. Use Output Configuration (OT.CF) to select the following:

- * To enable or disable the analog output
- * To determine if the analog output is current or voltage
- * To determine if the analog output is proportional to the display or to the error (the difference between reading and setpoint value)

15.1 To Enable or Disable The Analog Output

1. Press the **MENU** button until the meter shows “**OT.CF**”.
2. Press the **▶/DEV** button. The meter shows one of the following:
 - * “**O.1=D**” (Analog output disabled)
 - * “**O.1=E**” (*Analog output enabled*) (**Factory default**)
3. Press the **▲/MAX** button to toggle between choices.
4. Press the **▶/DEV** button to select analog output as current/voltage or press the **MENU** button to store your choice. The meter momentarily shows “**STRD**”, followed by “**OT.S.O**” (Output Scale and Offset - refer to Section 18) or “**P.BND**” (Proportional Band - refer to Section 16).

15.2 To Select Analog Output as Current or Voltage

1. Press the **▶/DEV** button. The meter shows one of the following:
 - * “**O.2=V**” (Analog output = voltage)
 - * “**O.2=C**” (*Analog output = current*) (**Factory default**)
2. Press the **▲/MAX** button to toggle between choices.
3. Press the **▶/DEV** button to select analog output/proportional or press the **MENU** button to store your choice. The meter momentarily shows “**STRD**”, followed by “**OT.S.O**” (Output Scale and Offset - refer to Section 18) or “**P.BND**” (Proportional Band - refer to Section 16).

15.3 To Select Analog Output or Proportional Control

To determine if the meter is to transmit an analog signal out proportional to your display or proportional to the error (proportional control) (The error is defined as the difference between reading and Setpoint 1 value).

If you have selected “**S.3=P**” in Setpoint 1 Configuration (“**S1.CF**” - refer to Section 11), you cannot program the meter for analog output proportional control. You may, however, use the regular analog output. If you have selected “**S.3=0**” in Setpoint 1 Configuration, then you may select analog output or proportional control as follows.

1. Press the **▶/DEV** button. The meter shows one of the following:
 - * “**O.3=A**” (*Analog output is retransmission of temperature*) (*Factory default*)
 - * “**O.3=P**” (Analog output is proportional to error between display reading and Setpoint 1)
2. Press the **▲/MAX** button to toggle between choices.
- 3a. If you select **O.3=A**, press the **MENU** button to store your choice. The meter momentarily shows “**STRD**”, followed by “**OT.S.O**” (Output Scale and Offset- refer to Section 18).
- 3b. If you select **O.3=P**, press the **▶/DEV** button. The meter shows one of the following:
 - * “**O.4=D**” (Proportional analog output is DIRECT ACTING)
 - * “**O.4=R**” (Proportional analog output is REVERSE ACTING).
4. Press the **▲/MAX** button to toggle between choices.
5. Press the **MENU** button to store your choice. The meter momentarily shows “**STRD**”, followed by “**P.BND**” (Proportional Band).

Additionally, if you select **O.2=V** (Analog output to be voltage), press the **▶/DEV** button. The meter shows one of the following:

- * “**O.5=F**” (Proportional 0-10 V analog output)
 - * “**O.5=H**” (Proportional 0-5 V analog output)
6. Press the **▲/MAX** button to toggle between choices.
 7. Press the **MENU** button to store your choice(s). The meter momentarily shows “**STRD**”, followed by “**P.BND**” (Proportional Band).

SECTION 16. PROPORTIONAL BAND (P.BND)

16.1 SELECTING PROPORTIONAL BAND (P.BND)

Proportional Band (**P.BND**) is not active unless your meter has analog output and relay capabilities. The menu will display whether analog output is present or not.

- A proportional controller's output is linearly proportional to the change of the error signal, whenever the signal is within 2 prescribed values (Proportional Band).
- There are three (3) points of interest on the proportional controller transfer curve.
- The first is the magnitude of the error signal that drives the controller to "full on" (e.g. 20 mA out for 4-20 mA).

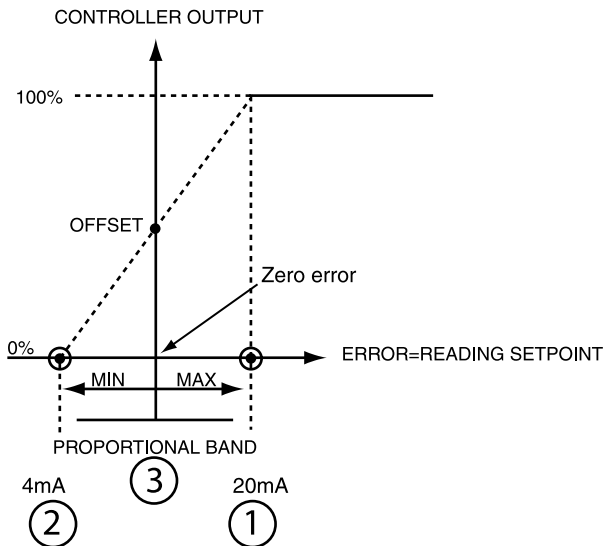

Figure 16-1. Controller Output

- The second point of interest is the magnitude of the error signal that drives the controller output to "full off" (e.g. 4 mA out on 4-20 mA). These two (2) points need not be equally spaced on either side of the zero error point.
- The third is the factor "Offset" and it is the output value of the controller which causes zero error.

The above example illustrates the parameters for the 4-20mA analog out, likewise, analog voltage output will have these (3) points of interest.

SECTION 16. PROPORTIONAL BAND (P.BND) (Continued)

If **A** is the controller gain the,

$$\text{Proportional Band} = \frac{\text{Max. out} - \text{Min. out}}{A}$$

$$\text{CONTROLLER OUT} = A * \text{ERROR} + \text{OFFSET}$$

To select the proportional band for your proportional controller, follow these steps:

1. Press the **MENU** button until the meter shows "**P.BND**".
2. Press the **▶/DEV** button. The meter shows the last previously stored 4- digit number (0000 through 9999) with flashing 4th digit.
3. Press the **▲/MAX** button to change the value of the flashing digit.
If you continue to press the **▲/MAX** button, the flashing digit's value continues to change.
4. Press the **▶/DEV** button to scroll to the next digit.
5. Press the **MENU** button to store your selection. The meter momentarily shows "**STRD**", followed by "**M.RST**" (Manual Reset).

Note *"P.BND" displays only if you select analog output as proportional.*

SECTION 17. MANUAL RESET (M.RST)

Manual Reset (**M.RST**) is not active unless your meter has analog output capabilities. The menu will display whether analog output is present or not. This feature allows you to offset the error that may occur within your setpoint. In order to determine the amount of error, you must compare your display value to the setpoint 1 value. The difference between these two values is the amount of error that you may want to enter into Manual Reset (**M.RST**).

1. Press the **MENU** button until the meter shows "**M.RST**".
2. Press the **▶/DEV** button. The meter shows last previously stored 4-digit number (-1999 through 9999) with flashing 4th digit.
3. Press the **▲/MAX** button to change the value of the flashing digit.
If you continue to press the **▲/MAX** button, the flashing digit's value continues to change.
4. Press the **▶/DEV** button to scroll to the next digit.
5. Press the **MENU** button to store your selection. The meter momentarily shows "**STRD**", followed also momentarily by "**RST**" (Reset). Then "**CJ.OF**" (Cold Junction Offset) displays (refer to Section 19).

Note *"M.RST" displays only if you select analog output as proportional.
Always choose the value of "M.RST" less than "P.BND/2".
Meter will not accept larger values and displays with flashing "ER 4".*

SECTION 18. OUTPUT SCALE AND OFFSET (OT.S.O)

Output Scale and Offset (**OT.S.O**) is not active unless your meter has analog output capabilities. The menu will display whether analog output is present or not. Output Scale and Offset (**OT.S.O**) scales your analog output to be equal to the meter's display and/or any engineering units you require. You may scale the output for direct (4-20 mA, 0-10 V, etc) or reverse acting (20-4 mA, 10-0 V, etc).

Note *"OT.S.O" only shows if you select analog output as a retransmission of temperature.*

1. Press the **MENU** button until the meter shows "**OT.S.O**".
2. Press the **▶/DEV** button. The meter shows "**RD 1**" (Read 1) .

Note *This is your first point of display reading.*

3. Press the **▶/DEV** button again. The meter shows the last previously stored 4-digit number (-1999 through 9999) with flashing 4th digit.
4. Press the **▲/MAX** button to change the value of Read 1.
5. Press the **▶/DEV** button to scroll to the next digit.
6. Press the **MENU** button to store your selection. The meter shows "**OUT.1**" (Output 1).

Note *This starting analog signal corresponds to your Read 1 display.*

7. Press the **▶/DEV** button. The meter shows selected output.

Note If you select "**0.2=V**" for voltage, the maximum signal you may select is 10.00 for an 0-10 V dc signal output. If you select "**0.2=C**" for current, the maximum signal you may select is 20.00 for a 0-20 or 4-20 mA dc signal output.

8. Press the **▲/MAX** button to enter the output 1 signal selection. If you continue to press the **▲/MAX** button, the flashing digit's value continues to change.

SECTION 18. OUTPUT SCALE AND OFFSET (OT.S.O) (Continued)

9. Press the **▶/DEV** button to scroll to the next digit.
10. Press the **MENU** button to store your selection. The display shows “**RD 2**” (Read 2).

 *This is your second point of display reading.*

11. Press the **▶/DEV** button. The last previously stored 4-digit number (-1999 through 9999) displays with flashing 4th digit.
12. Press the **▲/MAX** button to change the value of the flashing digit. If you continue to press the **▲/MAX** button, the flashing digit's value continues to change.
13. Press the **▶/DEV** button to scroll to the next digit.
14. Press the **MENU** button to store your selection. “**OUT.2**” (Output 2) displays.

 *This analog signal should correspond to your Read 2 display.*

15. Press the **▶/DEV** button. Selected output displays.

 *If you select “**O.2=V**” for voltage, the maximum signal you may select is 10.00 for an 0-10 V dc signal output. If you select “**O.2=C**” for current, the maximum signal you may select is 20.00 for a 0-20 or 4-20 mA dc signal output.*

16. Press the **▲/MAX** button to change the value of the flashing digit. If you continue to press the **▲/MAX** button, the flashing digit's value continues to change.
17. Press the **▶/DEV** button to scroll to the next digit.
18. Press the **MENU** button to store your selection. The meter momentarily shows “**STRD**”, followed also momentarily by “**RST**” (Hard Reset). “**CJ.OF**” (Cold Junction Offset) then displays.



WARNING: *If the meter displays all flashing values on any item, the value has overflowed. Press the **▲/MAX** button to start new values.*

SECTION 19. COLD JUNCTION OFFSET CALIBRATION (C.J.OF)

The cold junction offset equals the actual temperature minus the reading temperature. You may compensate for any error due to cold junction on the TC input. You may perform this compensation in any temperature from 0°C to 40°C (or 32°F to 104°F), however we recommend you perform this compensation at 0°C (32°F) for best result. To do this, immerse the thermocouple hot junctions into a mixture of ice and water. Check the Reading Configuration bit R.1 of the “**RD.CF**” menu setting for the proper temperature units.

TO PERFORM THIS COMPENSATION, FOLLOW THESE STEPS:

1. Connect the thermocouple wire to the (+) and (-) input.
2. Press the **MENU** button until meter displays “**CJ.OF**”.
3. Press the **▶/DEV** button. the meter displays the previous offset value with flashing 4th digit.
4. Press the **▶/DEV** button again. The reading temperature will be displayed (with no digit flashing).
- 5A. If the value is okay, then press the **MENU** button. The display will show “**STRD**” and 0 value will be entered at the offset.
- B. If the value is not okay, then enter the actual temperature using the **▶/DEV** and **▲/MAX** buttons. Once you enter the accurate temperature, press the **MENU** button. The meter displays “**STRD**” and stores the offset value.
 1. *Temperature unit is either celsius or fahrenheit and will always be displayed at 0.1 degree resolution. The meter flashes corresponding LED.*
 2. *MAX/MIN offset value will be ±25.0 °C or 45.0 °F. If offset the limit, the meter will flash “**ER 3**” and previous offset will not be changed.*

SECTION 20. LOCK OUT CONFIGURATION (LK.CF)

Use Lock Out Configuration (**LK.CF**) for the following:

- * To enable or disable the **RESET** button in the run mode.
- * To enable or disable setpoint changes

20.1 To Enable or Disable the RESET button in the Run Mode

1. Press the **MENU** button until the meter shows “**LK.CF**” after (“**C.J.OF**”).
2. Press the **▶/DEV** button until the meter shows “**RS.=E**” (*Factory default*).
3. Press the **▲/MAX** button to toggle between:
“**RS.=E**” *To enable the RESET button in the run mode (Factory default).*
“**RS.=D**” *To disable the RESET button in the run mode.*
4. Once desired mode shows, press the **MENU** button to store the change. The meter returns to the run mode.

20.2 To Enable or Disable Setpoint Changes

1. Press the **MENU** button until the meter shows “**LK.CF**” (after “**C.J.OF**”).
2. Press the **▶/DEV** button until the meter shows “**SP.=E**” (*Factory default*).
3. Press the **▲/MAX** button to toggle between:
“**SP.=E**” *To enable setpoint changes (Factory default).*
“**SP.=D**” *To disable setpoint changes*
4. Once desired mode shows, press the **MENU** button to store the change.

20.3 To Enable Display's Program Version:

1. Press the **MENU** button until the meter shows “**LK.CF**” (after “**C.J.OF**”).
2. Press the **▶/DEV** button until the meter shows one of the following:
 - * “**L.3=0**” “**SETPTS**” button will display setpoint values.
 - * “**L.3=1**” “**SETPTS**” button will display “**V.-03**” which is the meter's current software version.
3. Press the **▲/MAX** button to toggle between the choices above.
4. Press the **MENU** button to store the changes.

Note

If your meter does not have the relay option, setpoint menu items above will not be available and **SETPTS** button will always display the meter's software version. These units will have **+OL** (overload) or **+OPEN** memory indicated by Alarm 1 & 2 LED displays. LEDs can be reset by pressing **MENU** then **RESET** button or by power **OFF** then **ON**. These units can not use analog output proportional to error from setpoint 1. under menu OT.CF, 0.3=P.

SECTION 21. TUNING PROPORTIONAL CONTROLLER

The Proportional Controller is not active unless your meter has analog output capabilities. The menu will display whether analog output is present or not. This function allows you to tune your controller provided you have analog output capabilities. Select either Time Proportional Control or Analog and Proportional Control.

- * Select Time Proportional Control by setting “**S.3=P**” in Setpoint 1 Configuration (“**S1.CF**” - refer to Section 11).

or

- * Select Analog and Proportional Control by setting “**O.3=P**” in Output Configuration (“**OT.CF**” - refer to Section 15).

Include the meter in the process loop and turn on the meter. Allow enough time for the system to settle, then do the following.

1. Press the ►/**DEV** button. The meter momentarily shows “**DEV**” followed by a blinking value. This value is the deviation (error) between Reading and Setpoint 1 values. If there is no error (error is zero), your controller is tuned. If a value other than zero shows, proceed with step 2.
2. Press **RESET** button. The meter shows “**TUNE**”, tuning your controller and canceling any error. Once tuned, the meter shows “**RST**” and returns to the run mode.

 **Note** Allow enough time for process to settle before proceeding with “**TUNE**” procedure. If any error happens during this procedure, meter will flash “**ER 4**” and abort the tuning. You have to restart the procedure.

 **Note** “**TUNE**” will be active if your meter has analog output capabilities.

3. Press the ►/**DEV** button. Verify that blinking value is zero. If blinking value is not zero, repeat step 2.

SECTION 22. DISPLAY MESSAGES

Table 22-1. Display Messages

MESSAGE	DESCRIPTION
RST	Hard (power on) Reset
INPT	Input Type
DEC.P	Decimal Point
RD.CF	Reading Configuration
S1.CF	Setpoint 1 Configuration
S2.CF	Setpoint 2 Configuration
S1.DB	Setpoint 1 Deadband
TIME	Cycle Time for Time Proportional Controller
S2.DB	Setpoint 2 Deadband
OT.CF	Output Configuration
P.BND	Proportional Band
M.RST	Manual Reset
OT.S.O	Output Scale and Offset
C.J.OF	Cold Junction Offset
LK.CF	Lock out Configuration
TUNE	Tuning Proportional Controller
OPN	Sensor Breaker or Temperature Outside the Range
9999	Value Overflow in Setpoint/Menu Peak Deviation Routine
-1999	Value Overflow in Setpoint/Menu Peak Deviation Routine
ER1	2 Coordinate Format Programming Error
PEAK	Peak Value
PK.RS	Peak Reset
SP.RS	Reset Setpoints
SP1	Setpoint 1 Value
SP2	Setpoint 2 Value
ER2	One or more the following items have overflowed because of decimal point change: setpoint values, setpoint deadbands, proportional bands or manual reset.

SECTION 23. MENU CONFIGURATION

Not all menu items display on standard meters.

Table 23-1. Configuration Menu

(Defaults in Bold and Italics)

MENU	▶/DEV	▲/MAX
INPT Input Type	Show input choices:	J.TC Iron vs. Constantan (NIST) <i>K.TC Chromel vs. Alumel (NIST)</i> DJ.TC Iron vs. Copper (DIN) T.TC Copper vs. Copper-Nickel
DEC.P Decimal Point	Show decimal point position	<i>FFFF.</i> <i>FFF.F</i>
RD.CF Reading Configuration	R.1	C: Celsius <i>F: Fahrenheit</i>
S1.CF Setpoint 1 Configuration	S.1	<i>A: Active above</i> B: Active below
	S.2	<i>U: Unlatched</i> L: Latched
	S.3	<i>O: Setpoint 1 on/off ctrl</i> P: Setpoint 1 on time proportional control
	S.4	R: Reverse acting D: Direct acting
	S.5	S: Slow proportional control F: Fast proportional control
S2.CF Setpoint 2 Configuration	S.1	<i>A: Active above</i> B: Active below
	S.2	<i>U: Unlatched</i> L: Latched
S1.DB Setpoint 1 Deadband	Scroll right one digit	Change flashing digit's value Select from 0000 through 9999
S2.DB Setpoint 2 Deadband	Scroll right one digit	Change flashing digit's value Select from 0000 through 9999

SECTION 23. MENU CONFIGURATION (Continued)

Table 23-1. Configuration Menu (Continued)

(Defaults in Bold and Italics)

MENU	▶/DEV	▲/MAX
<p>OT.CF Output Configuration Analog Output</p>	<p>0.1</p> <p>0.2</p> <p>0.3</p> <p>0.4</p> <p>0.5</p>	<p>D: Disabled E: Enabled</p> <p>V: Voltage analog out C: Current analog out</p> <p>A: Retransmission of temperature P: Proportional to the error between display reading and SP1</p> <p>D: Proportional analog output is direct reading R: Proportional analog output is reverse acting</p> <p>F: 0-10 V proportional H: 0-5 V proportional</p>
<p>Notes: *If you select 0.2=V, you may select your analog output to be 0-10 V or 0-5V by accessing sub-menu 0.5=F or 0.5=H</p> <p>*If you select 0.3=O, you have access to Output Scale and Offset.</p> <p>*If you select 0.3=P, you may select your proportional output analog to be direct 0.4=D (4-20 mA, 0-5V, 0-10v) or reverse acting 0.4=R (20-4 mA, 5V-0V, 10V-0V).</p>		
<p>P.BND Proportional Band</p>	<p>Show prior value entered. Scroll right one digit.</p>	<p>Change flashing digit's value Select from 0000 through 9999</p>
<p>M.RST Manual Reset</p>	<p>Show prior value entered. Scroll right one digit.</p>	<p>Change flashing digit's value Select from 0000 through 9999</p>

SECTION 23. MENU CONFIGURATION (Continued)

Table 23-1. Configuration Menu (Continued)

(Defaults in Bold and Italics)

MENU	▶/DEV	▲/MAX
<p>OT.S.O Output Scale & Offset</p> <p>Enter new value & show “OUT1”</p> <p>Enter new value & show “RD 2”</p> <p>Enter new value & show “OUT2”</p>	<p>Show “RD 1” & prior value</p> <p>Scroll right one digit</p> <p>Show prior value</p> <p>Scroll right one digit</p> <p>Show prior value</p> <p>Scroll right one digit</p> <p>Show prior value</p>	<p>Change flashing digit's value</p> <p>Change flashing digit's value</p> <p>Change flashing digit's value</p>
<p>C.J.OF Cold Junction Offset</p>	<p>Show actual or prior value</p>	<p>Change flashing digit's value (°C only) Select from 0000 through 9999</p>
<p>LK.CF Lock Out Configuration</p>	<p>RS=</p> <p>SP=</p> <p>L3=</p>	<p><i>E</i> (Enable RESET button in run mode) <i>D</i> (Disable RESET button in run mode)</p> <p><i>E</i> (Enable setpoint changes) <i>D</i> (Disable setpoint changes)</p> <p><i>0</i> (SETPTS button display setpoint values) <i>1</i> (SETPTS button display software “v.-03” version)</p>

SECTION 23. MENU CONFIGURATION (Continued)

Table 23-2. Run Mode Displays

DISPLAY	▶/DEV	▲/MAX	RESET	DESCRIPTION
PEAK Peak Reading		Shows peak reading. Press again to return to the normal operating mode without resetting.	Reset peak reading when in this mode.	Shows highest reading since last reset
DEV	Press to activate		Tare proportional controller or exit deviation mode	Shows deviation value.
SP.RS				<p>LATCHED RESET</p> <p>Press RESET button to reset your setpoints.</p> <p> WARNING! This resets your tare if you are using this mode.</p>

SECTION 24. SETPOINT CONFIGURATION DISPLAYS

Table 24-1. Setpoint Configuration Displays

MENU	▶/DEV	▲/MAX	DESCRIPTION
SP 1 Setpoint 1	Scroll right one digit	Change the flashing digit's value	Select from -1999 through 9999
SP 2 Setpoint 2	Scroll right one digit	Change the flashing digit's value	Select from -1999 through 9999

SECTION 25. SPECIFICATIONS

SIGNAL INPUT

Thermocouple Types Temperature Ranges

J - Iron vs. Constantan (NIST)
-210° through 760°C
(-346° through 1400°F)

K - Chromel vs. Alumel (NIST)
-270° through 1372°C
(-454° through 2500°F)

DIN J - Iron vs. Constantan (DIN)
-200° through 900°C
(-328° through 1652°F)

T - Copper vs. Copper-Nickel
-270° through 400°C
(-454° through 752°F)

Isolation

Dielectric strength to 2500V transient per
3mm spacing based on EN 61010 for 260Vrms
or dc working voltage
NMR- 60 dB
CMR- 120 dB

Display

LED 14 segment, 13.8 mm (0.54")

Symbols



ANALOG TO DIGITAL

Technique

Dual slope

Internal Resolution

15 bits

Read Rate

3/sec

Polarity

Automatic

SECTION 25. SPECIFICATIONS (Continued)

ACCURACY AT 25°C	±0.5°C
Temperature Stability	0.04°C/°C
Step Response Time	1 seconds
Warm Up to Rated Accuracy	30 min

ANALOG OUTPUT (if applicable)

Signal Type	Current or voltage
Signal Level Current	10 V max compliance at 20 mA output
Signal Level Voltage	20 mA max for 0-10 V output
Function	May be assigned to a display range or proportional control output with setpoint #1 when used as a control output.
Linearity	0.2%
Step Response Time	2-3 seconds to 99% of the final value
4-20 mA Load Regulation	1.1%

ISOLATED ANALOG OUTPUT (if applicable)

Same as non-isolated analog output except isolated to 1000 Vdc.

Signal type	Current or voltage
Signal Level Current:	10 V max compliance at 20 mA output
Voltage:	20 mA max for 0-10 V output
Function	May be assigned to a display range or proportional control output with setpoint #1 when used as a control output.
Linearity	0.2%
Step Response Time	2 - 3 seconds to 99% of the final value

Only one analog output is available on each unit and it must be factory installed.

TRANSISTOR LOGIC OUT

(7 - 11) V ± 0.3 Vdc. Maximum current: 25 mA. Output may be configured as On/Off or Time Proportional for 0.1 to 199 seconds

PROPORTIONAL CONTROL (TIME OR ANALOG OUT)

Time	Cycle time for 0.1 second to 199 seconds. On/Off time to 99% of cycle time. Transistor and/or relay outputs. Configurable for reverse or direct acting. Front-panel tuning capability.
Analog	4-20 mA; 0-10 or 0-5 V out. Configurable for reverse or direct. Front-panel tuning capability.

SECTION 25. SPECIFICATIONS (Continued)

INPUT POWER INFORMATION

~ AC units	115/230 V~(AC) $\pm 10\%$, 50/60 Hz 7 W max, power consumption (Non-Isolated Analog Output) 8 W max, power consumption (Isolated Analog Output)
== DC units	10-32 Vdc 6 W max, power consumption (Non-Isolated Analog Output) 7 W max, power consumption (Isolated Analog Output)

External Fuse Protection Recommended:

ac	115 V	IEC 127-2/III, 125 mA, 250 V (T Type) or UL Slow-Blow, 175 mA, 250 V
ac	230 V	IEC 127-2/III, 63 mA, 250 V (T Type) or UL Slow-Blow, 80 mA, 250 V

ENVIRONMENT

Operating Temperature:	0° to 50°C (32° to 122°F) (115/230 V rms $\pm 10\%$)
Storage Temperature:	-40° to 85°C (-40° to 185°F)
Relative Humidity:	90% at 40°C (104°F) (non-condensing)

MECHANICAL

Panel Cutout:	1/8 DIN 3.62 x 1.77" (92 x 45mm)
Weight:	1.27 lb (574 g)
Case Material:	Polycarbonate, 94 V-O UL rated

ALARM OUTPUTS (if applicable)

	2 Form "C" on/off relays. Configurable for on/off and latched/unlatched by software. Relay 1 may also be configured for Time Proportional from 5 seconds to 199 seconds.
Max Current:	5 AMPS, Resistive Load
Max Voltage:	250 V ac or 30 V dc

SECTION 25. SPECIFICATIONS (Continued)

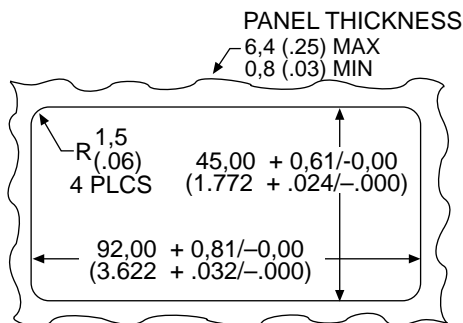
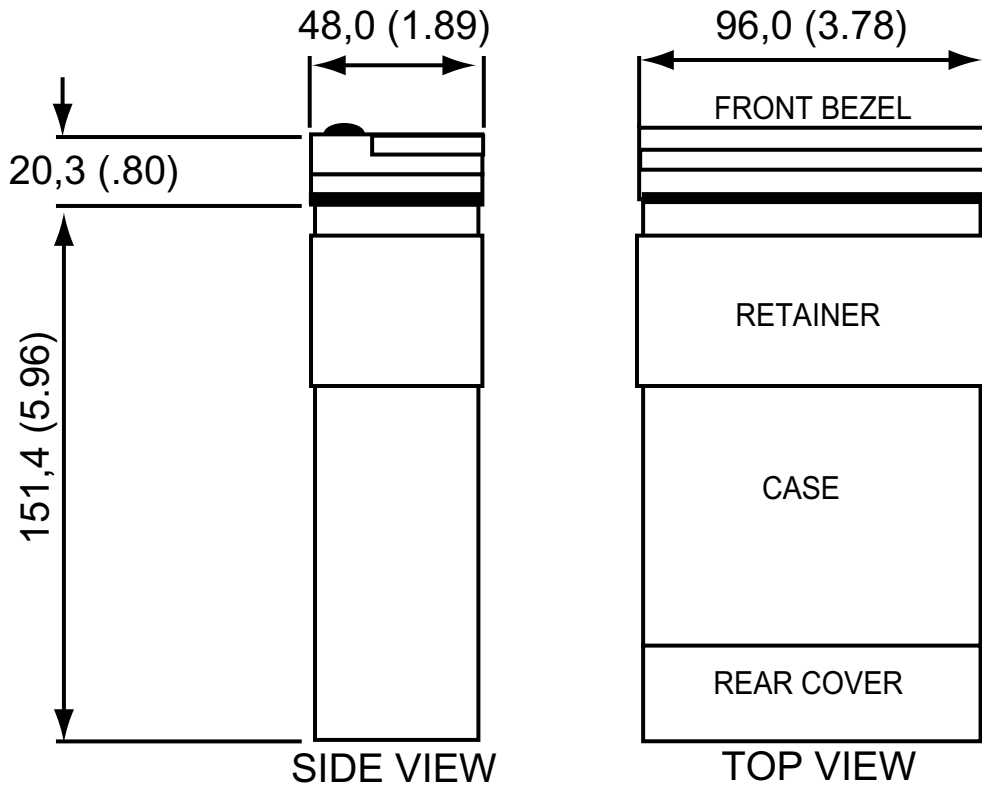

NOTE: Dimensions in Millimeters (Inches)

Figure 25-1 Meter Dimensions

SECTION 26. FACTORY PRESET VALUES

Table 26-1. Factory Preset Values

MENU ITEM	FACTORY PRESET VALUES
INPT	Input Type: K.TC (Type K T/C)
DEC.P	Decimal Point Position: FFFF.
RD.CF	Reading Configuration: R.1=F (Fahrenheit)
S1.CF	Setpoint 1 Configuration: S.1=A (Setpoint is active above) S.2=U (Setpoint is unlatched) S.3=O (On/Off control)
S2.CF	Setpoint 2 Configuration: S.1=A (Setpoint is active above) S.2=U (Setpoint is unlatched)
S1.DB	Setpoint 1 Deadband: 030.0
S2.DB	Setpoint 2 Deadband: 030.0
OT.CF	Output Configuration: O.1=E (Analog output is enabled) O.2=C (Analog output is current) O.3=A (Analog output follows the display value)
OT.S.O	Output Scale and Offset: 0-1000 = 4-20 mA dc
CJ.OF	0000
LK.CF	Lock Out Configuration RS=E (Enable the RESET button in the run mode) SP=E (Enable setpoint changes) L3=0 (SETPTS button display setpoint values)
SP1	Setpoint 1 Value: 0000
SP2	Setpoint 2 Value: 0000

CE APPROVALS INFORMATION

 This product conforms to the EMC directive 89/336/EEC amended by 93/68/EEC, and with the European Low Voltage Directive 72/23/EEC.

Electrical Safety EN61010-1:2001

Safety requirements for electrical equipment for measurement, control and laboratory.

Double Insulation

Pollution Degree 2

Dielectric withstand Test per 1 min

- Power to Input/Output: 2300 Vac (3250 Vdc)
- Power to Input/Output: 500 Vac (720 Vdc)
(Low Voltage dc Power Option*)
- Power to Relays Output: 2300 Vac (3250 Vdc)
- Relay 1 to Relay 2: 2300 Vac (3250 Vdc)
- Isolated Analog to Inputs: 1000 Vac (1420 Vdc)
- Analog to Inputs: No Isolation

Measurement Category I

Category I are measurements performed on circuits not directly connected to the Mains Supply (power). Maximum Line-to-Neutral working voltage is 50 Vac/dc. This unit should not be used in Measurement Categories II, III, IV.

Transients Overvoltage Surge (1.2 / 50uS pulse)

- Input Power: 2500 V
- Input Power: 500 V
(Low Voltage dc Power Option*)
- Isolated Analog: 500 V
- Input/Output Signals: 500 V

Note: *Units configured for external low power dc voltage, 10-32 Vdc (Basic Insulation)

EMC EN61326:1997 + and A1:1998 + A2:2001

Immunity and Emissions requirements for electrical equipment for measurement, control and laboratory.

- EMC Emissions Table 4, Class B of EN61326
- EMC Immunity** Table 1 of EN61326

Note: **I/O signal and control lines require shielded cables and these cables must be located on conductive cable trays or in conduits. Furthermore, the length of these cables should not exceed 30 meters



Refer to the EMC and Safety installation considerations (Guidelines) of this manual for additional information.



WARRANTY/DISCLAIMER

OMEGA ENGINEERING, INC. warrants this unit to be free of defects in materials and workmanship for a period of **one (1) year** from the date of purchase. In addition to OMEGA's standard warranty period, OMEGA Engineering will extend the warranty period for **four (4) additional years** if the warranty card enclosed with each instrument is returned to OMEGA.

If the unit malfunctions, it must be returned to the factory for evaluation. OMEGA's Customer Service Department will issue an Authorized Return (AR) number immediately upon phone or written request. Upon examination by OMEGA, if the unit is found to be defective, it will be repaired or replaced at no charge. OMEGA's WARRANTY does not apply to defects resulting from any action of the purchaser, including but not limited to mishandling, improper interfacing, operation outside of design limits, improper repair, or unauthorized modification. This WARRANTY is VOID if the unit shows evidence of having been tampered with or shows evidence of having been damaged as a result of excessive corrosion; or current, heat, moisture or vibration; improper specification; misapplication; misuse or other operating conditions outside of OMEGA's control. Components which wear are not warranted, including but not limited to contact points, fuses, and triacs.

OMEGA is pleased to offer suggestions on the use of its various products. However, OMEGA neither assumes responsibility for any omissions or errors nor assumes liability for any damages that result from the use of its products in accordance with information provided by OMEGA, either verbal or written. OMEGA warrants only that the parts manufactured by it will be as specified and free of defects. OMEGA MAKES NO OTHER WARRANTIES OR REPRESENTATIONS OF ANY KIND WHATSOEVER, EXPRESS OR IMPLIED, EXCEPT THAT OF TITLE, AND ALL IMPLIED WARRANTIES INCLUDING ANY WARRANTY OF MERCHANTABILITY AND FITNESS FOR A PARTICULAR PURPOSE ARE HEREBY DISCLAIMED. LIMITATION OF LIABILITY: The remedies of purchaser set forth herein are exclusive, and the total liability of OMEGA with respect to this order, whether based on contract, warranty, negligence, indemnification, strict liability or otherwise, shall not exceed the purchase price of the component upon which liability is based. In no event shall OMEGA be liable for consequential, incidental or special damages.

CONDITIONS: Equipment sold by OMEGA is not intended to be used, nor shall it be used: (1) as a "Basic Component" under 10 CFR 21 (NRC), used in or with any nuclear installation or activity; or (2) in medical applications or used on humans. Should any Product(s) be used in or with any nuclear installation or activity, medical application, used on humans, or misused in any way, OMEGA assumes no responsibility as set forth in our basic WARRANTY/DISCLAIMER language, and, additionally, purchaser will indemnify OMEGA and hold OMEGA harmless from any liability or damage whatsoever arising out of the use of the Product(s) in such a manner.

RETURN REQUESTS/INQUIRIES

Direct all warranty and repair requests/inquiries to the OMEGA Customer Service Department. BEFORE RETURNING ANY PRODUCT(S) TO OMEGA, PURCHASER MUST OBTAIN AN AUTHORIZED RETURN (AR) NUMBER FROM OMEGA'S CUSTOMER SERVICE DEPARTMENT (IN ORDER TO AVOID PROCESSING DELAYS). The assigned AR number should then be marked on the outside of the return package and on any correspondence.

The purchaser is responsible for shipping charges, freight, insurance and proper packaging to prevent breakage in transit.

FOR WARRANTY RETURNS, please have the following information available BEFORE contacting OMEGA:

1. Purchase Order number under which the product was PURCHASED,
2. Model and serial number of the product under warranty, and
3. Repair instructions and/or specific problems relative to the product.

FOR NON-WARRANTY REPAIRS, consult OMEGA for current repair charges. Have the following information available BEFORE contacting OMEGA:

1. Purchase Order number to cover the COST of the repair,
2. Model and serial number of product, and
3. Repair instructions and/or specific problems relative to the product.

OMEGA's policy is to make running changes, not model changes, whenever an improvement is possible. This affords our customers the latest in technology and engineering.

© Copyright 2005 OMEGA ENGINEERING, INC. All rights reserved. This document may not be copied, photocopied, reproduced, translated, or reduced to any electronic medium or machine-readable form, in whole or in part, without the prior written consent of OMEGA ENGINEERING, INC.

TRADEMARK NOTICE:  *omega.com*[®] and  **OMEGA** are trademarks of OMEGA Engineering, Inc.

PATENT NOTICE: This product is covered by one or more of the following patents: U.S. Pat. No. Des. 336,895; 5,274,577; 6,243,021 / CANADA 2052599; 2052600 / ITALY 1249456; 1250938 / FRANCE BREVET No. 91 12756 / SPAIN 2039150; 2048066 / UK PATENT No. GB2 249 837; GB2 248 954 / GERMANY DE 41 34398 C2. The "Meter Case Bezel Design" is a trademark of NEWPORT Electronics, Inc., registered in the U.S. USED UNDER LICENSE. Other US and International Patents pending or applied for.

Where Do I Find Everything I Need for Process Measurement and Control? OMEGA...Of Course!

Shop on line at www.omega.com

TEMPERATURE

- Thermocouple, RTD & Thermistor Probes, Connectors, Panels & Assemblies
- Wire: Thermocouple, RTD & Thermistor
- Calibrators & Ice Point References
- Recorders, Controllers & Process Monitors
- Infrared Pyrometers

PRESSURE, STRAIN AND FORCE

- Transducers & Strain Gauges
- Load Cells & Pressure Gauges
- Displacement Transducers
- Instrumentation & Accessories

FLOW/LEVEL

- Rotameters, Gas Mass Flowmeters & Flow Computers
- Air Velocity Indicators
- Turbine/Paddlewheel Systems
- Totalizers & Batch Controllers

pH/CONDUCTIVITY

- pH Electrodes, Testers & Accessories
- Benchtop/Laboratory Meters
- Controllers, Calibrators, Simulators & Pumps
- Industrial pH & Conductivity Equipment

DATA ACQUISITION

- Data Acquisition & Engineering Software
- Communications-Based Acquisition Systems
- Plug-in Cards for Apple, IBM & Compatibles
- Datalogging Systems
- Recorders, Printers & Plotters

HEATERS

- Heating Cable
- Cartridge & Strip Heaters
- Immersion & Band Heaters
- Flexible Heaters
- Laboratory Heaters

ENVIRONMENTAL MONITORING AND CONTROL

- Metering & Control Instrumentation
- Refractometers
- Pumps & Tubing
- Air, Soil & Water Monitors
- Industrial Water & Wastewater Treatment
- pH, Conductivity & Dissolved Oxygen Instruments