

® ACC-PS1

® Current Source

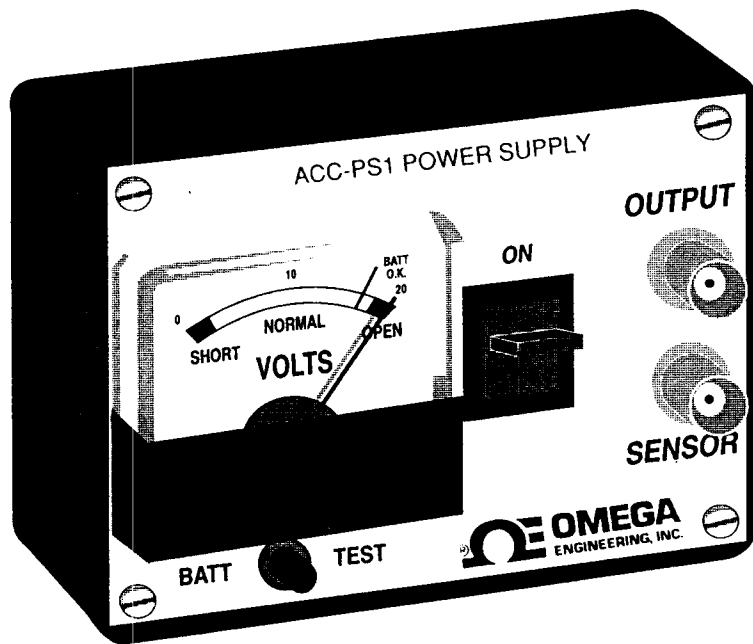

Operator's Manual
M1641/0493

ACC-PS1 TABLE OF CONTENTS

Section	Page Number
Introduction	1
Unpacking the Current Source	1
Description	1
Operation	1-2
Coupling Time Constant	2
Optional Direct Coupled Connection	2-3
High-Frequency Response	3
Changing Batteries	3
Maintenance	3
Specifications	3

INTRODUCTION

The OMEGA Model ACC-PS1 Current Source is a battery operated unit designed to power dynamic sensors, i.e., transducers containing integral impedance converting electronics.

This type of sensor requires a source of constant current (in the range of 2 to 20 mA) supplied at +18 to +30 VDC level.

The ACC-PS1 supplies 2 mA at +18 VDC. Both current and voltage are fixed, i.e., not adjustable as with most other OMEGA power units.

Energy is supplied by two 9 Volt transistor radio batteries.

A voltmeter on the front panel of the ACC-PS1 monitors the operating voltage of the sensor and checks for opens and shorts in cables and connectors.

A press-to-test button checks battery condition without disturbing the test in progress.

The "Sensor" and "Output" jacks are BNC coaxial connectors.

UNPACKING THE CURRENT SOURCE

Remove the packing list and verify that you have received all equipment. If you have questions about the shipment, please call the OMEGA Customer Service Department at (800) 622-2378 or (203) 359-1660.

Upon receipt of shipment, inspect the container and equipment for any signs of damage. Note any evidence of rough handling in transit. Immediately report any damage to the shipping agent.

DESCRIPTION

The ACC-PS1 utilizes a 2 mA current regulating diode (see Figure 1) to set the sensor current. The metering circuit draws only $25\mu\text{A}$ at midscale position. With this low current drain, the battery life with alkaline batteries is about 80 hours of operation.

Figure 1 is a schematic diagram of the ACC-PS1. As you can see, the voltmeter normally monitors the voltage at the "sensor" connection which verifies normal bias voltage of the sensor electronics. This steady state bias or "turn-on" voltage is nominally +10 Volts for most sensors. Consult the calibration sheet for each particular sensor to verify the actual bias voltage.

The "Batt Test" switch momentarily connects the meter directly across the batteries to check battery voltage even during operation.

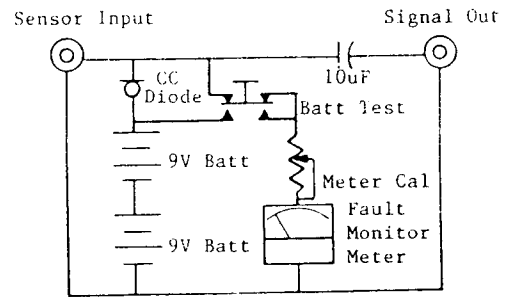

FIGURE 1 - Schematic Diagram Model ACC-PS1

The dynamic signal from the sensor is superimposed on the +11 bias level and is decoupled by the $10\mu\text{f}$ coupling capacitor connected from the "Sensor" jack to the "Output" jack.

It can be seen that the sensor signal can also be measured by connecting to the "Sensor" jack.

This connection can be useful when it becomes desirable to direct couple the readout to the sensor rather than to AC couple. We discuss this optional connection later in the manual.

OPERATION

Connect the sensor to the "Sensor" connector to the ACC-PS1. Refer to Figure 2.

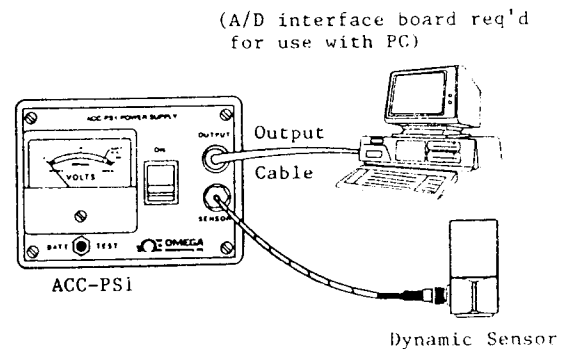

FIGURE 2 - Typical System Interconnection

1. Connect the "Output" jack to the input of the readout instrument (Oscilloscope, Voltmeter, Recorder). The BNC "Output" jack on the ACC-

PS1 eliminates the need for special connector adaptors to connect to the readout.

2. Move the power switch lever to the "ON" position and wait a few seconds for the sensor to warm up and for the coupling capacitor to fully charge. The readout may indicate a voltage "drift" while these events are occurring.
3. When conditions stabilize, observe the front panel voltmeter. Normal operation of the sensor is indicated by an approximate mid-scale reading (in the "Normal" area).
4. Depress the "Batt Test" pushbutton and observe the battery voltage. The meter should indicate to the right of the "Batt OK" line on the meter face with fresh batteries in the unit. When this test shows the battery voltage below this line (approximately 17 Volts) the batteries should be replaced.

While the sensor will continue to function with low batteries, clipping may occur at the positive end of the waveform as +5 Volt signal level is approached.

Should an input cable from the sensor become shorted, the meter will indicate to the extreme left hand end of the scale in the "Short" area. Disconnecting sensor and cables should aid in quickly diagnosing the problem.

Conversely, should an open circuit occur in the sensor cable, the meter will indicate to the extreme right end of the scale ("Open" area).

NOTE: The meter can test for opens and shorts only in the sensor circuit and not in the output circuit.

After the measurement is made, be sure to promptly turn the power switch "OFF" to conserve batteries.

COUPLING TIME CONSTANT

The low frequency response of any AC coupled system is limited by the coupling time constant (TC) of the system. The coupling capacitor and readout constitute a high pass first order filter.

The coupling time constant is the product of the coupling capacitor (Farads) and the input resistance of the readout (Ohms). The result is in seconds.

The relationship between the lower -3db frequency and the coupling time constant is:

$$f_{(-3db)} = \frac{.16}{TC \text{ (Seconds)}} \text{ Hz}$$

For a readout input resistance of 10 megaohms, the coupling TC is 100 seconds (10 megaohms X 10 μ f).

Using the above equation, we obtain a lower -3db frequency of:

$$f = \frac{.16}{100} = .0016 \text{ Hz}$$

The -5% frequency for this case is three times the -3db frequency or .0048 Hz.

In this manner, the low frequency limitation of any system can be calculated if the input resistance of the readout instrument is known.

OPTIONAL DIRECT COUPLED CONNECTION

To avoid the low frequency limitation as described in the previous section, it is possible to use the "Sensor" jack (see Figure 3) to observe the output signal, direct coupled.

However, the readout must have the capability of neutralizing the approximate +11 VDC sensor bias.

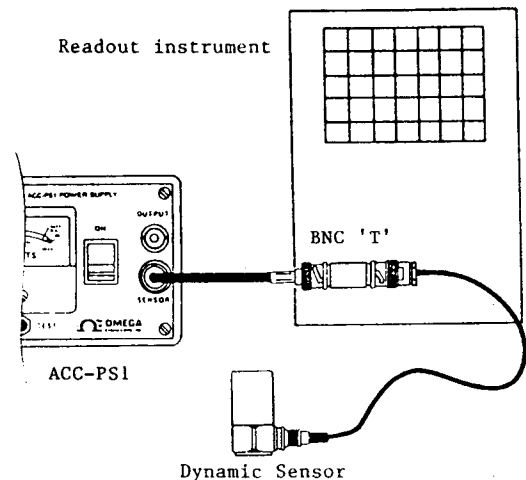

FIGURE 3 - Direct Coupled Connection

The connection shown in Figure 3 would normally be used when quasi-static response is

desired such as for calibration of long time constant force sensor (like Model DLC101) by static means.

HIGH FREQUENCY RESPONSE

The high frequency response of any piezo-electric measurement system is determined by a number of factors. These are:

1. The HF response of the sensor.
2. The length and type of cable used between power unit and sensor.
3. The drive current to the sensor electronics.

The user has no control over the amount of drive current supplied by the Model ACC-PS1. It is fixed at 2 mA.

In most cases, this should be sufficient to drive cables up to 100 feet without degradation of high frequency response. Experimentation is the only sure way to determine the effect of cable length and type on the HF response of any given measurement situation.

CHANGING BATTERIES

When a change of batteries is indicated, proceed as follows:

1. Remove the four screws in each corner of the front panel and remove the unit from the case.
2. Carefully remove the snap connectors from the batteries using care not to stress the wires to these connectors.
3. Remove the worn batteries from the battery clips and replace with Duracell MN1604 or equivalent 9V battery.

Alkaline and Mercury batteries will give extended life over the Carbon/Zinc (Zinc Chloride) types; however, some of these are slightly larger and may not fit in the clips and/or case of the ACC-PS1.

Do not force an oversized battery into the clip as to do so may break the clip. Also, if a larger battery is forced into the clip, it may become impossible to reassemble the unit into the case without forcing, which may damage the unit.

MAINTENANCE

Aside from battery replacement, there is no routine maintenance required on the ACC-PS1.

Should the meter require re-zeroing, a zero adjustment is located at the front of the meter face.

It is not likely that the meter should need recalibration, but should this need arise, a potentiometer for this purpose is located at the rear of the meter.

Electrical connectors may be cleaned with a soft brush dipped in Freon TF® or equivalent.

Avoid solvents such as methylene chloride which will attack plastic and other materials.

ACC-PS1 SPECIFICATIONS

No. of Channels:	1
Excitation Voltage (Vdc):	18
Excitation Current (mA):	2
Voltage gain ($\pm 2\%$):	1
Output Signal F.S. Peak (Vdc): (dependant on bias voltage)	8
Noise (RMS mV) (0-10kHz):	0.06
Input Power	(2) 9V Batt:
Accelerometer Connector:	BNC
Output Connector:	BNC
Dimensions (L x W x H):	2 x 3 x 4 inches
Weight (Oz.):	11
Battery Life:	80 hrs.



WARRANTY

OMEGA warrants this unit to be free of defects in materials and workmanship and to give satisfactory service for a period of **13 months** from date of purchase. OMEGA Warranty adds an additional one (1) month grace period to the normal **one (1) year product warranty** to cover handling and shipping time. This ensures that our customers receive maximum coverage on each product. If the unit should malfunction, it must be returned to the factory for evaluation. Our Customer Service Department will issue an Authorized Return (AR) number immediately upon phone or written request. Upon examination by OMEGA, if the unit is found to be defective it will be repaired or replaced at no charge. However, this WARRANTY is VOID if the unit shows evidence of having been tampered with or shows evidence of being damaged as a result of excessive corrosion; or current, heat, moisture or vibration; improper specification; misapplication; misuse or other operating conditions outside of OMEGA's control. Components which wear or which are damaged by misuse are not warranted. These include contact points, fuses, and triacs.

We are glad to offer suggestions on the use of our various products. Nevertheless OMEGA only warrants that the parts manufactured by it will be as specified and free of defects.

OMEGA MAKES NO OTHER WARRANTIES OR REPRESENTATIONS OF ANY KIND WHATSOEVER, EXPRESSED OR IMPLIED, EXCEPT THAT OF TITLE AND ALL IMPLIED WARRANTIES INCLUDING ANY WARRANTY OF MERCHANTABILITY AND FITNESS FOR A PARTICULAR PURPOSE ARE HEREBY DISCLAIMED.

LIMITATION OF LIABILITY: The remedies of buyer set forth herein are exclusive and the total liability of OMEGA with respect to this order, whether based on contract, warranty, negligence, indemnification, strict liability or otherwise, shall not exceed the purchase price of the component upon which liability is based. In no event shall OMEGA be liable for consequential, incidental or special damages.

Every precaution for accuracy has been taken in the preparation of this manual; however, OMEGA ENGINEERING, INC. neither assumes responsibility for any omissions or errors that may appear nor assumes liability for any damages that result from the use of the products in accordance with the information contained in the manual.

RETURN REQUESTS / INQUIRIES

Direct all warranty and repair requests/inquiries to the OMEGA ENGINEERING Customer Service Department. Call toll free in the USA and Canada: 1-800-622-2378, FAX: 203-359-7811; International: 203-359-1660, FAX: 203-359-7807.

BEFORE RETURNING ANY PRODUCT(S) TO OMEGA, YOU MUST OBTAIN AN AUTHORIZED RETURN (AR) NUMBER FROM OUR CUSTOMER SERVICE DEPARTMENT (IN ORDER TO AVOID PROCESSING DELAYS). The assigned AR number should then be marked on the outside of the return package and on any correspondence.

FOR **WARRANTY** RETURNS, please have the following information available BEFORE contacting OMEGA:

1. P.O. number under which the product was PURCHASED,
2. Model and serial number of the product under warranty, and
3. Repair instructions and/or specific problems you are having with the product.

FOR **NON-WARRANTY** REPAIRS OR **CALIBRATION**, consult OMEGA for current repair/calibration charges. Have the following information available BEFORE contacting OMEGA:

1. Your P.O. number to cover the COST of the of the repair/calibration,
2. Model and serial number of product, and
3. Repair instructions and/or specific problems you are having with the product.

OMEGA's policy is to make running changes, not model changes, whenever an improvement is possible. That way our customers get the latest in technology and engineering.

OMEGA is a registered trademark of OMEGA ENGINEERING, INC.

© Copyright 1993 OMEGA ENGINEERING, INC. All rights reserved including illustrations. Nothing in this manual may be reproduced in any manner, either wholly or in part for any purpose whatsoever without written permission from OMEGA ENGINEERING, INC.