

CE

MADE IN
USA

User's Guide

Shop on line at

omega.com[®]

— OMEGA[®] —

omega.com

e-mail: info@omega.com

For Latest Product Manuals

omegamannual.info

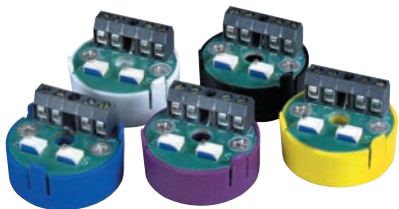

TX94A **RTD Ultra-Mini** **Temperature Transmitter**

omega.com[®]Ω OMEGA[®]**OMEGAnet[®] On-Line Service**
www.omega.com**Internet e-mail**
info@omega.com**Servicing North America:****USA:**ISO 9001 Certified

One Omega Drive, P.O. Box 4047

Stamford CT 06907-0047

TEL: (203) 359-1660

FAX: (203) 359-7700

e-mail: info@omega.com

Canada:

976 Bergar

Laval (Quebec) H7L 5A1

TEL: (514) 856-6928

FAX: (514) 856-6886

e-mail: info@omega.ca

For immediate technical or application assistance:**USA and Canada:**Sales Service: 1-800-826-6342 / 1-800-TC-OMEGA[®]Customer Service: 1-800-622-2378 / 1-800-622-BEST[®]Engineering Service: 1-800-872-9436 / 1-800-USA-WHEN[®]**Mexico and****Latin American:**

TEL: (001) 203-359-7803

FAX: (001) 203-359-7807

e-mail: espanol@omega.com

Servicing Europe:**Benelux:**

TEL: +31 20 3472121

FAX: +31 20 6434643

Toll Free in Benelux: 0800 0993344

e-mail: sales@omegaeng.nl

Czech Republic:

Frystatska 184, 733 01 Karviná

TEL: +420 59 6311899

FAX: +420 59 6311114

e-mail: info@omegashop.cz

France:

TEL: +33 1 61 37 29 00

FAX: +33 1 30 57 54 27

Toll Free in France: 0800 466 342

e-mail: sales@omega.fr

Germany/Austria:

Daimlerstrasse 26, D-75392 Deckenpfronn, Germany

TEL: +49 7056 9398-0

FAX: +49 7056 9398-29

Toll Free in Germany: 0800 639 7678

e-mail: info@omega.de

United Kingdom:ISO 9001 Certified

One Omega Drive

River Bend Technology Centre

Northbank, Irlam, Manchester M44 5BD United Kingdom

TEL: +44 161 777 6611 FAX: +44 161 777 6622

Toll Free in England: 0800 488 488

e-mail: sales@omega.co.uk

It is the policy of OMEGA to comply with all worldwide safety and EMC/EMI regulations that apply.

OMEGA is constantly pursuing certification of its products to the European New Approach Directives. OMEGA will add the CE mark to every appropriate device upon certification.

The information contained in this document is believed to be correct, but OMEGA Engineering, Inc. accepts no liability for any errors it contains, and reserves the right to alter specifications without notice.

WARNING: These products are not designed for use in, and should not be used for, patient-connected applications.



This device is marked with the international caution symbol. It is important to read the Setup Guide before installing or commissioning this device as the guide contains important information relating to safety and EMC.

TABLE OF CONTENTS

Section 1	Getting Started	
	1.1 Unpacking	1
	1.2 Safety and EMC Considerations	1
	1.3 General Description	2
	1.4 Features	2
	1.5 Models Available	3
Section 2	Installation	
	2.1 Mounting	4
	2.2 Wiring	5
Section 3	Calibration Instructions	
	3.1 Equipment Required	6
	3.2 Set-up of Equipment.	6
	3.3 Calibration Procedures.	7
Section 4	Troubleshooting Guide	8
Section 5	Specifications	9

FIGURES & TABLES

Figure 1-1	RTD Transmitter	2
Figure 2-1	Assembly inside a Protection Head	4
Figure 2-2	Wiring Diagram for RTD Transmitter	5
Figure 3-1	Transmitter Calibration Set-Up	7
Figure 5-1	Dimensions	9
Table 1-1	Range Code	3
Table 1-2	Model Numbers	3
Table 3-1	Calibration Values	7

1.1 Unpacking

Remove the packing list and verify that you have received all equipment. If you have any questions, contact the nearest Customer Service Department, as listed on the cover of this manual.

Upon receipt of shipment, inspect the container and equipment for any signs of damage. Note any evidence of rough handling in transit. Immediately report any damage to the shipping agent.

Note

Note: The carrier will not honor any claims unless all shipping material is saved for their examination. After examining and removing contents, save packing materials and carton in the event reshipment is necessary.

1.2 Safety and EMC Considerations

This instrument is a Class III device (8 to 35 Vdc).

Always use a power supply, which complies with EN 60950 safety standard.

- Do not expose the transmitter to rain or condensing moisture.
- Do not operate the transmitter in flammable or explosive atmosphere.
- As with any electronic instrument, you may encounter high voltage exposure when installing, calibrating or removing parts of the transmitter.

EMC Considerations

- Whenever EMC is an issue, always use shielded cables.
- Never run signal and power wires in the same conduit.
- Use signal wire connections with twisted-pair cables.
- Install Ferrite Bead(s) on signal wires close to the instrument if EMC problems persist.

Failure to follow all instructions and warnings may result in injury!

1.3 General Description

The Two-Wire RTD Transmitter will produce a standard 4-20mA output signal proportional to that produced by its RTD input temperature sensor. Transmission of the proportional current output may be accomplished by using inexpensive copper wire. The RTD transmitter accepts two-wire or three-wire ohm platinum RTD sensors (PT100, $\alpha = 0.00385$).

1.3 General Description

The transmitter is normally powered by an unregulated power supply as shown in **Figure 1-1**. The proportionally-transmitted signal begins at 4mA, at the low end of its temperature range, and increases to 20mA, at the high end of its temperature range. (There are various temperature ranges available for the transmitter. To order, refer to **Section 1.5** for correct Model Numbers and Range Codes.)

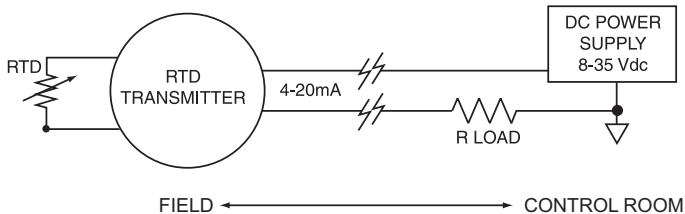

Figure 1-1 RTD Transmitter

The transmitter works with 2 or 3-wire RTDs and provides an output current of 4-20mA proportional to the RTD Sensor.

When the transmitter is mounted inside a protection head, (see **Figure 2-1**), two copper wires now carry the temperature signal and dc voltage to operate the transmitter, thereby reducing possible noise pick-up errors.

The transmitter does NOT provide isolation between its input and the 4-20 mA output. Note, however, that the RTD element is electrically insulated.

1.4 Features

- +/-0.1% full-scale accuracy (with respect to the RTD input resistance)
- 4-20 mA output
- Upscale break protection
- Low Cost

1.5 Models Available

Table 1-1 Range Code

INPUT TYPES

RANGE	RTD
-40 to 120 F (-40 to 49 C)	1
0 to 200 F (-18 to 93 C)	2
0 to 300 F (-18 to 149 C)	3
0 to 500 F (-18 to 260 C)	4
0 to 750 F (-18 to 399 C)	5
0 to 1000 F (-18 to 538 C)	6

Table 1-2 Model Numbers

Model Number	Description
TX94A-(*)	RTD Transmitter (100 ohm, Pt, alpha=0.00385)

*Insert range code from **Table 1-1**

2.1 Mounting

The transmitter may be:

1. surface mounted
2. mounted inside a protection head (shown in **Figure 2-1**)

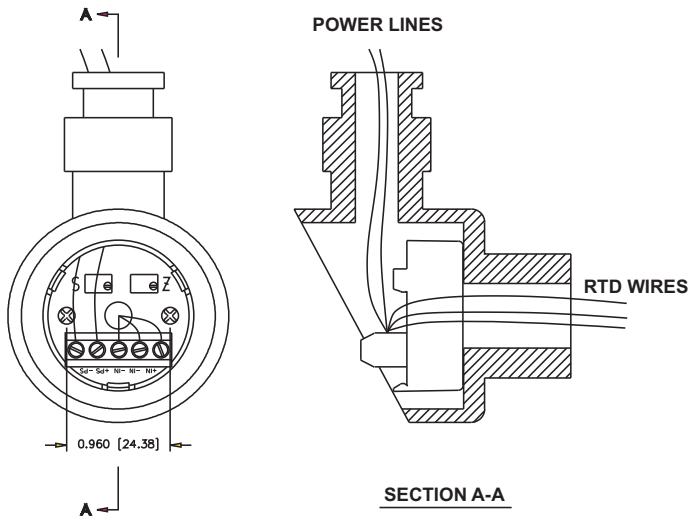

Figure 2-1 Assembly of the Transmitter inside an PR-14 Protection Head

2.2 Wiring

Refer to **Figure 2-2**

1. Connect a dc power supply in series with the load to the (+PS) and (-PS) power terminals. Note that the load (usually a monitoring instrument) may be connected to either the (+) or (-) power lead.
2. Connect the RTD element to the (+IN) and (-IN) input terminals.

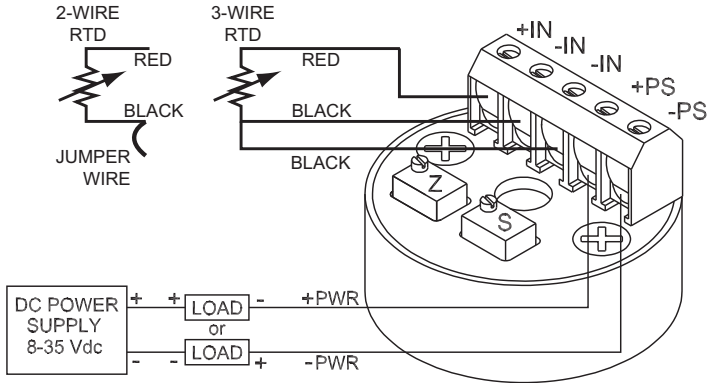

Figure 2-2 Wiring Diagram for RTD Transmitter

3.1 Equipment Required

- Precision Decade Resistance Box, with 0.01 ohm resolution and ± 0.02 ohm accuracy
or
- Precision RTD Simulator, such as OMEGA CL511 Precision Calibrator
- Precision DMM capable of measuring mA, within 0.001 mA resolution and ± 0.002 mA accuracy

3.2 Calibration Procedures

Connect the calibration equipment according to **Figure 3-1**. Standard copper test leads are used with RTD instrumentation.

To check or adjust the calibration:

1. Locate the Z (zero) and S (span) potentiometers.
2. Select, from **Table 3-1**, the correct ohmic values for the Z (zero) and S (span) adjustments that correspond to the model number.
For example, for Model TX94A-2, the Z value is 92.95 ohms, and the S value is 135.84 ohms.

If a Thermocouple/RTD Simulator is used, such as the Model CL511 Precision Calibrator, select the Temperature Input Z (zero) and S (span) values.

3. Set the Decade Box to the selected Z (zero) ohmic value. Adjust the Z potentiometer to read 4.000 mA on the monitoring instrument.
4. Set the Decade Box to the selected S (span) ohmic value. Adjust the S potentiometer to read 20.000 mA on the monitoring instrument.
5. Repeat steps 3 and 4, as required, until the readings are exactly 4.000 mA and 20.000 mA. This procedure is necessary since there is interaction between the two potentiometers.

3.2 Calibration Procedures (continued)

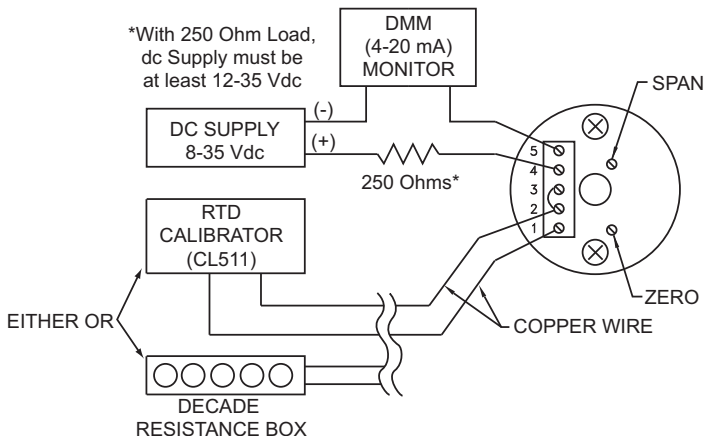

Figure 3-1 Transmitter Calibration Set-Up

Table 3-1. Calibration Values

Temperature Input Range Zero/Span	Model TX94A	Resistance Input (Ohms) Alpha=0.00385 Zero/Span
-40/120°F	-1	84.27 / 119.01
0/200°F	-2	92.95 / 135.84
0/300°F	-3	92.95 / 156.94
0/500°F	-4	92.95 / 197.69
0/750°F	-5	92.95 / 246.69
0/1000°F	-6	92.95 / 293.46

4.1 Troubleshooting Guide

Malfunction or incorrect operation may be caused by:

1. Incorrect Readings:

Check for improper wiring using **Figure 2-2** as a guide.

2. Loose or broken wires:

Check each terminal connection for tightness. Move each wire back and forth and note any changes in operation.

3. Too high a load resistance in the output current loop or too low a current rating on the power supply:

a) Measure the total resistance of each device (excluding the transmitter and power supply) in the 20 mA loop, including the resistance of the lead wires.

b) Calculate maximum allowable loop resistance using the formula: Loop Resistance (maximum) = $\frac{V_{\text{supply}} - 8 \text{ V}}{0.020\text{A}}$

For example, a 24V power supply would give a maximum loop resistance of: $16 \text{ V} / 0.020\text{A} = 800 \text{ ohms}$.

c) Make sure the power supply is rated for at least 28 mA times the number of transmitters being powered. For example, if the supply is powering five transmitters, the supply should be rated for at least 140mA.

5.1 Specifications (continued)

Output

Current Output Span:	4-20 mA dc
Current Output Limits:	3 to 28 mA, typical
Max Loop Resistance:	$(V_{\text{supply}} - 8V) / 0.020A = \text{ohms}$
Load Resistance Effect:	0.01% of span per 300 ohms change
Power Supply Effect:	0.002% of output span per volt

Input

Sensor:	2 or 3-wire RTD
Max. Bridge Current:	2 mA



WARRANTY/DISCLAIMER

OMEGA ENGINEERING, INC. warrants this unit to be free of defects in materials and workmanship for a period of **one (1) year** from the date of purchase. In addition to OMEGA's standard warranty period, OMEGA Engineering will extend the warranty period for **one (1) additional year** if the warranty card enclosed with each instrument is returned to OMEGA.

If the unit malfunctions, it must be returned to the factory for evaluation. OMEGA's Customer Service Department will issue an Authorized Return (AR) number immediately upon phone or written request. Upon examination by OMEGA, if the unit is found to be defective, it will be repaired or replaced at no charge. OMEGA's WARRANTY does not apply to defects resulting from any action of the purchaser, including but not limited to mishandling, improper interfacing, operation outside of design limits, improper repair, or unauthorized modification. This WARRANTY is VOID if the unit shows evidence of having been tampered with or shows evidence of having been damaged as a result of excessive corrosion; or current, heat, moisture or vibration; improper specification; misapplication; misuse or other operating conditions outside of OMEGA's control. Components which wear are not warranted, including but not limited to contact points, fuses, and triacs.

OMEGA is pleased to offer suggestions on the use of its various products. However, OMEGA neither assumes responsibility for any omissions or errors nor assumes liability for any damages that result from the use of its products in accordance with information provided by OMEGA, either verbal or written. OMEGA warrants only that the parts manufactured by it will be as specified and free of defects. OMEGA MAKES NO OTHER WARRANTIES OR REPRESENTATIONS OF ANY KIND WHATSOEVER, EXPRESS OR IMPLIED, EXCEPT THAT OF TITLE, AND ALL IMPLIED WARRANTIES INCLUDING ANY WARRANTY OF MERCHANTABILITY AND FITNESS FOR A PARTICULAR PURPOSE ARE HEREBY DISCLAIMED. LIMITATION OF LIABILITY: The remedies of purchaser set forth herein are exclusive, and the total liability of OMEGA with respect to this order, whether based on contract, warranty, negligence, indemnification, strict liability or otherwise, shall not exceed the purchase price of the component upon which liability is based. In no event shall OMEGA be liable for consequential, incidental or special damages.

CONDITIONS: Equipment sold by OMEGA is not intended to be used, nor shall it be used: (1) as a "Basic Component" under 10 CFR 21 (NRC), used in or with any nuclear installation or activity; or (2) in medical applications or used on humans. Should any Product(s) be used in or with any nuclear installation or activity, medical application, used on humans, or misused in any way, OMEGA assumes no responsibility as set forth in our basic WARRANTY/DISCLAIMER language, and, additionally, purchaser will indemnify OMEGA and hold OMEGA harmless from any liability or damage whatsoever arising out of the use of the Product(s) in such a manner.

RETURN REQUESTS / INQUIRIES

Direct all warranty and repair requests/inquiries to the OMEGA Customer Service Department. BEFORE RETURNING ANY PRODUCT(S) TO OMEGA, PURCHASER MUST OBTAIN AN AUTHORIZED RETURN (AR) NUMBER FROM OMEGA'S CUSTOMER SERVICE DEPARTMENT (IN ORDER TO AVOID PROCESSING DELAYS). The assigned AR number should then be marked on the outside of the return package and on any correspondence.

The purchaser is responsible for shipping charges, freight, insurance and proper packaging to prevent breakage in transit.

FOR **WARRANTY RETURNS**, please have the following information available BEFORE contacting OMEGA:

1. Purchase Order number under which the product was PURCHASED,
2. Model and serial number of the product under warranty, and
3. Repair instructions and/or specific problems relative to the product.

FOR **NON-WARRANTY REPAIRS**, consult OMEGA for current repair charges. Have the following information available BEFORE contacting OMEGA:

1. Purchase Order number to cover the COST of the repair,
2. Model and serial number of product, and
3. Repair instructions and/or specific problems relative to the product.

OMEGA's policy is to make running changes, not model changes, whenever an improvement is possible. This affords our customers the latest in technology and engineering.

© Copyright 2009 OMEGA ENGINEERING, INC. All rights reserved. This document may not be copied, photocopied, reproduced, translated, or reduced to any electronic medium or machine-readable form, in whole or in part, without the prior written consent of OMEGA ENGINEERING, INC.

TRADEMARK NOTICE:  **®**, omega.com**®**, and  **OMEGA****®** are Trademarks of OMEGA ENGINEERING, INC.

PATENT NOTICE: PATENT NOTICE: The "Meter Case Bezel Design" is a trademark of NEWPORT Electronics, Inc., registered in the U.S. USED UNDER LICENSE. This product is covered by one or more of the following patents: U.S. Pat. No. Des. 336,895; 5,274,577 / CANADA 2052599; 2052600 / ITALY 1249456; 1250938 / FRANCE BREVET No. 91 12756 / SPAIN 2039150; 2048066 / UK PATENT No. GB2 249 837; GB2 248 954 / GERMANY DE 41 34398 C2. OTHER INTERNATIONAL PATENTS PENDING.

Where Do I Find Everything I Need for Process Measurement and Control? **OMEGA...Of Course!** *Shop on line at omega.com*

TEMPERATURE

- Thermocouple, RTD & Thermistor Probes, Connectors, Panels & Assemblies
- Wire: Thermocouple, RTD & Thermistor
- Calibrators & Ice Point References
- Recorders, Controllers & Process Monitors
- Infrared Pyrometers

PRESSURE, STRAIN AND FORCE

- Transducers & Strain Gauges
- Load Cells & Pressure Gauges
- Displacement Transducers
- Instrumentation & Accessories

FLOW/LEVEL

- Rotameters, Gas Mass Flowmeters & Flow Computers
- Air Velocity Indicators
- Turbine/Paddlewheel Systems
- Totalizers & Batch Controllers

pH/CONDUCTIVITY

- pH Electrodes, Testers & Accessories
- Benchtop/Laboratory Meters
- Controllers, Calibrators, Simulators & Pumps
- Industrial pH & Conductivity Equipment

DATA ACQUISITION

- Data Acquisition & Engineering Software
- Communications-Based Acquisition Systems
- Plug-in Cards for Apple, IBM & Compatibles
- Datalogging Systems
- Recorders, Printers & Plotters

HEATERS

- Heating Cable
- Cartridge & Strip Heaters
- Immersion & Band Heaters
- Flexible Heaters
- Laboratory Heaters

ENVIRONMENTAL MONITORING AND CONTROL

- Metering & Control Instrumentation
- Refractometers
- Pumps & Tubing
- Air, Soil & Water Monitors
- Industrial Water & Wastewater Treatment
- pH, Conductivity & Dissolved Oxygen Instruments