



# User's Guide

**Shop online at**

**omega.com\***

Ω OMEGA\*

*omega.com*

*e-mail: info@omega.com*

*For latest product manuals:*

*omegamanual.info*

ISO 9001

CERTIFIED  
CORPORATE QUALITY

STAMFORD, CT

ISO 9002

CERTIFIED  
CORPORATE QUALITY

MANCHESTER, UK

## CN 74000

**omega.com®**

ΩOMEGA®

OMEGAnet® Online Service  
omega.com

Internet e-mail  
info@omega.com

### Servicing North America:

**U.S.A.:**  
ISO 9001 Certified

One Omega Drive, Box 4047  
Stamford, CT 06907-0047  
Tel: (203) 359-1660  
FAX: (203) 359-7700  
e-mail: info@omega.com

**Canada:**

976 Bergar  
Laval (Quebec) H7L 5A1, Canada  
Tel: (514) 856-6928  
FAX: (514) 856-6886  
e-mail: info@omega.ca

### For immediate technical or application assistance:

**U.S.A. and Canada:** Sales Service: 1-800-826-6342/1-800-TC-OMEGA®  
Customer Service: 1-800-622-2378/1-800-622-BEST®  
Engineering Service: 1-800-872-9436/1-800-USA-WHEN®

**Mexico:**

En Español: (001) 203-359-7803  
e-mail: espanol@omega.com  
FAX: (001) 203-359-7807  
info@omega.com.mx

### Servicing Europe:

**Czech Republic:**

Frystatska 184, 733 01 Karvina, Czech Republic  
Tel: +420 (0)59 6311899  
FAX: +420 (0)59 6311114  
Toll Free: 0800-1-66342  
e-mail: info@omegashop.cz

**Germany/Austria:**

Daimlerstrasse 26, D-75392 Deckenpfronn, Germany  
Tel: +49 (0)7056 9398-0  
FAX: +49 (0)7056 9398-29  
Toll Free in Germany: 0800 639 7678  
e-mail: info@omega.de

**United Kingdom:**

ISO 9002 Certified

One Omega Drive, River Bend Technology Centre  
Northbank, Irlam, Manchester  
M44 5BD United Kingdom  
Tel: +44 (0)161 777 6611  
FAX: +44 (0)161 777 6622  
Toll Free in United Kingdom: 0800-488-488  
e-mail: sales@omega.co.uk

It is the policy of OMEGA Engineering, Inc. to comply with all worldwide safety and EMC/EMI regulations that apply. OMEGA is constantly pursuing certification of its products to the European New Approach Directives. OMEGA will add the CE mark to every appropriate device upon certification.

The information contained in this document is believed to be correct, but OMEGA accepts no liability for any errors it contains, and reserves the right to alter specifications without notice.

**WARNING:** These products are not designed for use in, and should not be used for, human applications.

# INSTRUCTIONS FOR THE CN74000 1/32 DIN MICROPROCESSOR BASED TEMPERATURE / PROCESS CONTROL

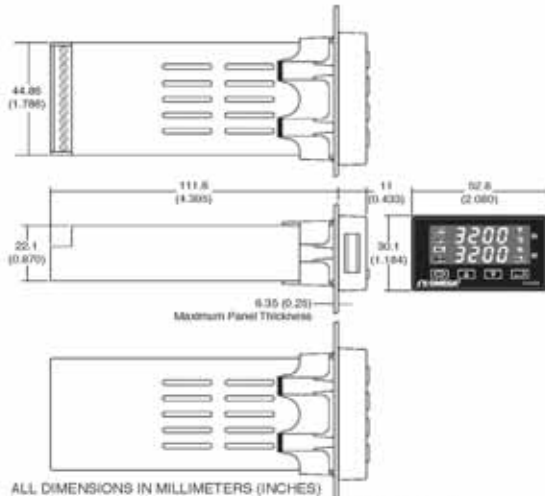

PANEL CUT OUT: 45 +0.6 X 22.2 +0.3 (1.772 +0.02 X 0.874 +0.012)



**OMEGA®** OMEGA Engineering

One Omega Drive  
Stamford, Connecticut 06907-0047  
P.O. Box 4047  
Telephone: 800/848-4286; 203/359-1660  
Fax: 203/359-7700

# CONTENTS

INSTALLATION .....	4
WIRING .....	5
Wiring for Optional Inputs and Outputs .....	6
Wiring for 4 to 20mA Transmitter inputs .....	7
FRONT PANEL KEY FUNCTIONS .....	8
NOTATION CONVENTIONS FOR THE MENUS .....	10
THE HOME DISPLAY .....	10
PROGRAMMING AND OPERATION FOR RAMP / SOAK FEATURE .....	11
Theory of Operation .....	11
Program Setup .....	11
Ramp / Soak Operation .....	13
AUTO / MANUAL OPERATION .....	13
OPERATION OF SELF TUNE® FUNCTION .....	14
Theory of Operation .....	14
Option C4, Serial Communication .....	15
CHANGING PROGRAMMING FOR SET POINT 2 AND ALARM .....	16
FACTORY DEFAULT PROCEDURE .....	16
ALARM TYPE AND ACTION .....	17
MENU SELECTIONS .....	18
PRIMARY MENU .....	18
SECONDARY MENU .....	19
SECURE MENU .....	26
SPECIFICATIONS .....	32
DIAGNOSTIC ERROR MESSAGES .....	34-35
DIMENSIONS .....	Front Page

# GETTING STARTED

1. Install the control as described on page 4.
2. Wire your control following the instructions on page 5. If you are using a two-wire transmitter as an input, see the drawing and instructions on page 7. Option wiring instructions are on page 6. Option descriptions are on page 4, and specific instructions start on page 17.
3. Most controls do not need many (if any) program changes to work on your process. For best results when programming changes are necessary, make all the necessary changes in the Secure Menu (page 26) before making changes to the Secondary Menu (page 19). If error messages occur, check the Diagnostic Error Messages on page 34 and 35 for help.

Take the example of a Series CN74000 that comes from the factory programmed for type J thermocouples. Suppose for this example you wish to change the input to type K and limit the set point range between 0° and 1000° C.

First, enter the Secure menu as instructed on page 5. Press the INDEX key until the display shows **Inp** and press the DOWN ARROW until the display shows **CA**. Don't forget to press the ENTER key to retain your setting.

Next, press the INDEX key to display **Unit**. Press the DOWN ARROW until the display shows **C**. Press ENTER.

Next, press the INDEX key until **SPL** is displayed (pass the **dPt** and **InPt** selections). Press the UP ARROW until the display shows **0**. Press ENTER.

Finally, press INDEX key to display **SPH**. Press the DOWN ARROW until the display shows **1000**. Press ENTER.

The necessary program changes are now complete. After 60 seconds the display will switch back to the temperature reading. If you want to return faster, press the UP ARROW and ENTER keys (at the same time) and then press the DOWN ARROW and INDEX keys (again at the same time). This will 'back out' of the menu and immediately display the temperature reading.

If you want to use Self Tune<sup>®</sup>, Auto/Manual, or the Ramp/Soak Programmer features, see the special sections on these items. Page numbers for these are in the Contents section on the previous page.

## MODEL IDENTIFICATION

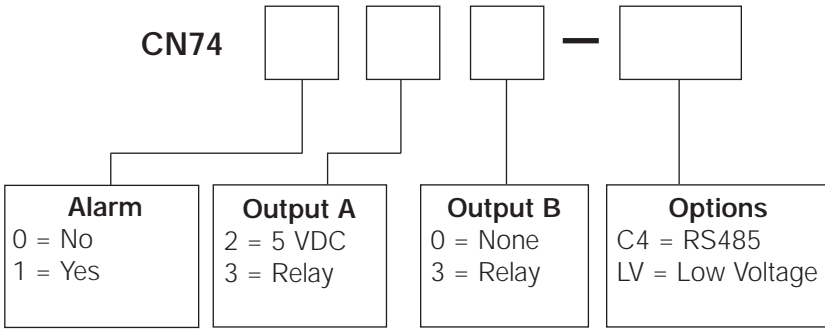

Options:

C4 RS-485 Serial Communications. Allows remote computer to read and write all control parameters.

LV 12-24 VDC/VAC 50-400 Hz power supply (control operates on low voltage equipment).

Note: Only Option LV may be combined with another option. No other options may be combined.

## INSTALLATION

Mount the instrument in a location that will not be subject to excessive temperature, shock, or vibration. All models are designed for mounting in an enclosed panel.

Select the position desired for the instrument on the panel. If more than one instrument is required, maintain the minimum of spacing requirements as shown on the drawing opposite. Closer spacing will structurally weaken the panel, and invalidate the IP66, UL type 4 rating of the panel.



**It is not necessary to remove the control chassis from the housing for installation. If the control chassis is removed from the housing, you must follow industry standard practice for control and protection against Electro-Static Discharge (ESD). Failure to exercise good ESD practices may cause damage to the control.**

Prepare the panel by cutting and deburring the required opening(s).

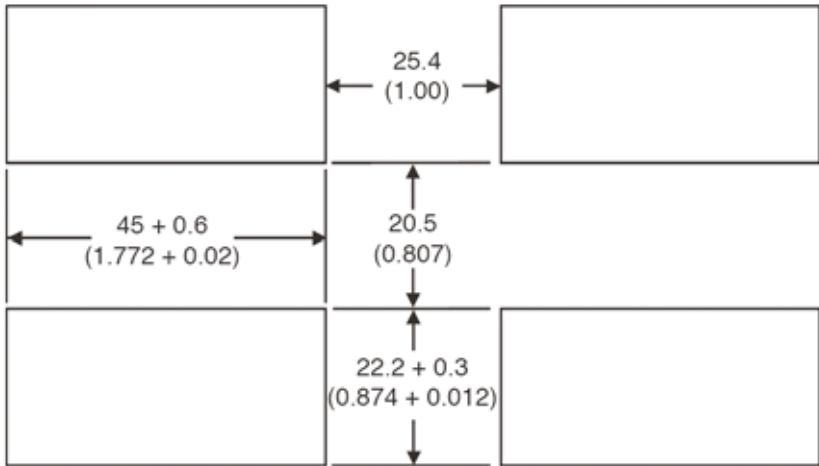

From the front of the panel, slide the housing through the cutout. The housing gasket should be flat against the housing flange before installing.

From the rear of the panel slide the mounting collar over the housing. Hold the housing with one hand and using the other hand, push the collar evenly against the panel until the spring loops are slightly compressed. The ratchets will hold the mounting collar and housing in place. To remove, gently lift the ratchets and slide a piece of heavy paper or mylar sheet under each ratchet (a business card works well). Slide the collar off of the housing.

## WIRING

Do not run thermocouple or other class 2 wiring in the same conduit as power leads. Use only the type of thermocouple or RTD probe for which the control has been programmed. Maintain separation between wiring of sensor, auxiliary in or out, and other wiring. See the "Secure Menu" for input selection.

For thermocouple input always use extension leads of the same type designated for your thermocouple.

For supply connections use No. 18 AWG wires rated for at least 75°C. Use copper conductors only. All line voltage output circuits must have a common disconnect and be connected to the same pole of the disconnect.

Input wiring for thermocouple, current, and RTD; and output wiring for current, DC SSR, and 5 VDC is rated CLASS 2.

Control wiring is as shown.

The wiring terminals for the CN74000 are compression type. To open the wiring terminal, turn the screw for that terminal counterclockwise. Slide the wire into the terminal space. While holding the wire in place, turn the screw clockwise to tighten. Maximum torque is 0.424 N•m (3.75 in lb). Do not overtighten. The wire should be held snugly in place.

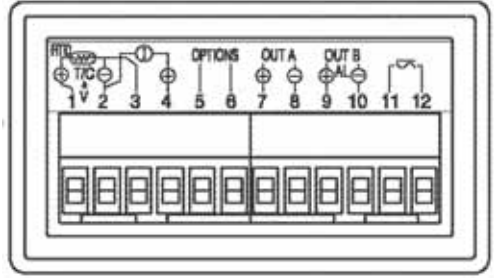

## Wiring for Optional Inputs and Outputs

Wire power and outputs as shown on page 5 and 6. Wiring for options is shown below. All wiring shown below is Class 2. Shielded twisted pair is required for Option C4.



**DO NOT RUN SIGNAL WIRING IN THE SAME CONDUIT OR CHASE AS THE POWER WIRING. ERRATIC OPERATION OR DAMAGE TO THE CONTROL CIRCUITRY WILL RESULT.**

OPTION	Term. 5	Term. 6
C4	Note 1	

Note 1:

Terminal 5 is line A (-)

Terminal 6 is line B (+)

Last control in chain must have 120 ohm  $\pm 1\%$  resistor across 5 and 6.

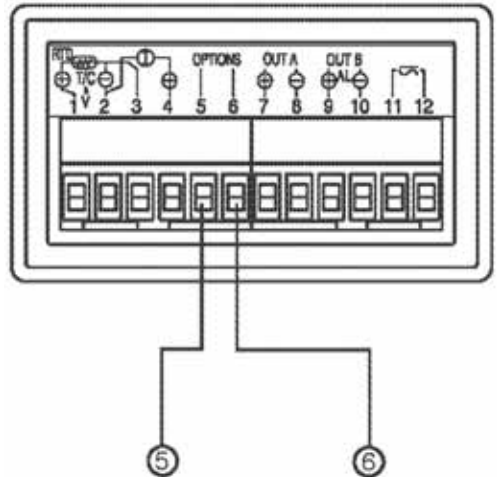

## Wiring for 4 to 20mA Transmitter Inputs

Wire power and outputs as shown above. Two-wire transmitters wire as shown below.

For three or four wire transmitters, follow the wiring instructions provided with your transmitter.



**DO NOT WIRE THE 24 VOLT POWER SUPPLY ACROSS THE INPUT OF THE CONTROL. DAMAGE TO THE CONTROL INPUT CIRCUITRY WILL RESULT.**

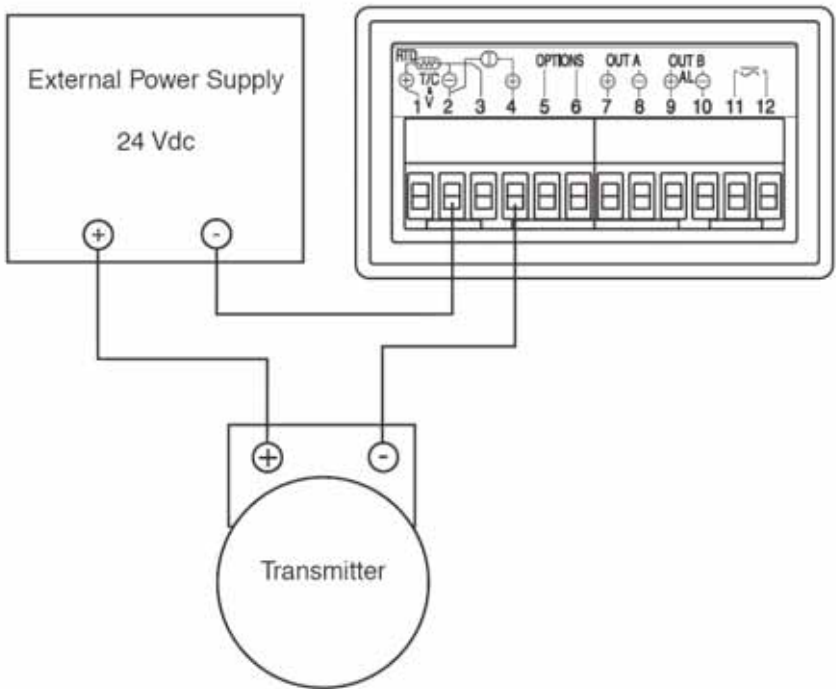

## FRONT PANEL KEY FUNCTIONS

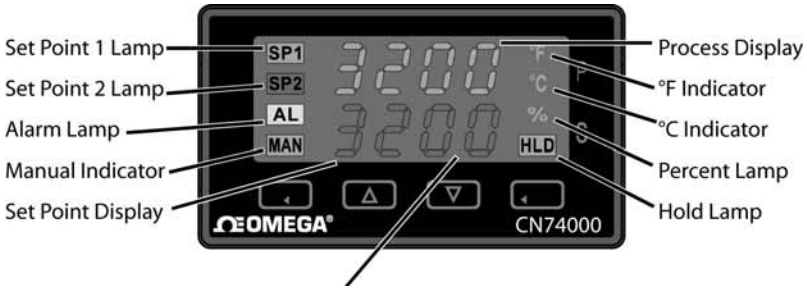

The decimal point flashes when Self-Tune is operating.  
Keys are illuminated when pressed. Key functions are as follows:



**INDEX:** Pressing the INDEX key advances the display to the next menu item. May also be used in conjunction with other keys as noted below.



**UP ARROW:** Increments a value, changes a menu item, or selects the item to ON. The maximum value obtainable is 9999 regardless of decimal point placement.



**DOWN ARROW:** Decrements a value, changes a menu item, or selects the item to OFF. The minimum value obtainable is -1999 regardless of decimal point placement.



**ENTER:** Pressing ENTER stores the value or the item changed. If not pressed, the previously stored value or item will be retained. The display will flash once when ENTER is pressed.

**UP ARROW & ENTER:** Pressing these keys simultaneously brings up the **secondary menu** starting at the alarm, tune, or cycle item (depending on programming). Pressing these keys for 5 seconds will bring up the **secure menu**.

**INDEX & DOWN ARROW:** Pressing these keys simultaneously will allow backing up one menu item, or if at the first menu item they will cause the display to return to the **primary menu**. If an alarm condition has occurred, these keys may be used to reset the alarm. To reset an alarm press and hold both keys for three seconds.

**INDEX & ENTER:** Pressing these keys simultaneously and holding them for 5 seconds allows recovery from the various error messages. The following menu items will be reset:

**ALiH:** Alarm inhibit

**OPeN InP:** Input error message

**bAd InP:** Input error message

**CHEC CAL:** Check calibration error

**Correct the problems associated with the above conditions before using these reset keys.** More than one error could be present. Caution is advised since several items are reset at one time.

While in the **Primary or Secondary Menu**, if no key is pressed for a period of 30 seconds, the display will return to the HOME position displaying the temperature value. While in the **Secure Menu**, if no key is pressed for a period of 60 seconds, the display will return to the HOME position displaying the temperature value. Outputs are disabled (turned off) when the **Secure Menu** is active.

**NOTE:** To move to the **Primary Menu** quickly from any other menu, press the **UP ARROW & ENTER** keys followed by pressing the **INDEX & DOWN ARROW** keys.

## SECURITY LEVEL SELECTION

Four levels of security are provided. The display shows the current security level. To change security levels change the password value using the **UP & DOWN ARROW** keys and pressing the **ENTER** key. Refer to the password table (following) for the correct value to enter for the security level desired. The **SECr** menu item security level may be viewed or changed at any time regardless of the present security level.

To set the access level to, for example, **2**, at the **SECr** menu item press the **UP ARROW** key until the upper display show the password, **1101**. Press the **ENTER** key. The display will blink, and return with the level value, **2**, in the upper display.

The password values shown in the table cannot be altered, so retain a copy of these pages for future reference. This is the only reference made to password values in this instruction book.

## PASSWORD TABLE

Security Level Menu Status	Displayed Value When Viewed	Password Value to Enter
Primary Locked Secondary Locked Secure Locked	1	1110
Primary Unlocked Secondary Locked Secure Locked	2	1101
Primary Unlocked Secondary Unlocked Secure Locked	3	1011
Primary Unlocked Secondary Unlocked Secure Unlocked	4	111

## NOTATION CONVENTIONS FOR THE MENUS

Because of the number of features available in this control, information is included that may not apply to your specific control. All usable features are included in this book, but may not be used in your process. To increase clarity the following conventions are used:

1. Certain features, Menu Items, and functions shown in this book may or may not appear on your control, depending on other Menu Item selections. At various places in the Menus there are notes identifying Menu Items that "control" or "direct" other menu items. If you are looking for a particular menu item and can't find it, check the menu item that is its "control" for proper setting.
2. The "#" symbol is used in two ways. It is used inside a group of characters to indicate which set point function (SP1 or SP2) is being affected. It is also used before a group of characters of a menu item to indicate that there may be more than one selection or value for that menu item. This is used for certain repeated items such as in the Ramp/Soak Program section.
3. *Features that apply only to Options will be printed in Italics.*

## THE HOME DISPLAY

The home display is the normal display while the control is operating. If no errors or functions are active, the HOME display will indicate the Process Variable (the temperature, pressure, flow, RH, etc., that is being measured) on the top display and the Set Variable (Set Point 1) on the bottom.

Items that can change the HOME display are the Auto/Manual function, the **Prog** function, the **PctO** function, and any error message. Description of these special displays follow.

If Auto/Manual is enabled, the Manual indicator lights, and the home display is changed. The upper display continues to show the Process Variable (PV), but the lower display changes to show the percentage of output in tenths of a percent to 99.9% (0.0 to 99.9), or 100 if 100%. The display digit to the right of the number shows a flashing letter **O** to indicate that the value displayed is no longer the SV, but percent output. The SP2 output is indicated by the use of an overline on the letter **O**. Access to the SP2 value is done by the INDEX key. See Auto/Manual Operation on Page 13 for further information.

If **Prog** is turned **On**, the HOME display changes the SV display from SP1 to the Present Set Variable as calculated by the Ramp/Soak Programmer function. See Programming and Operation for Ramp/Soak Feature for more information.

If **PctO** (Secondary Menu) is turned **On**, the lower display changes to show the active percentage of output as required to maintain SP1. The display is similar to the Auto/Manual display above, except that the letter indicators do not flash, and the output is displayed in whole percentages of output, not in tenths of a percent. If the control has both SP1 and SP2, the lower display will alternate between the SP1 percent output and the SP2 percent output.

Error messages are listed on Page 34 and 35.

## **PROGRAMMING AND OPERATION FOR RAMP / SOAK FEATURE**

The ramp / soak feature offers a great deal of flexibility by allowing changes in the set point to be made over a predetermined period of time. Soak (dwell) times can be programmed, and the alarm output relay can be programmed to open or close during any of the segments.

### **Theory of Operation**

The CN74000 Series controls offer a very simple approach to programming a ramp. Rather than requiring the operator to calculate an approach rate (usually in degrees per minute), the CN74000 does the calculation internally. Thus, the operator only needs to program the target set point and the time desired to reach that point. When the ramp segment is executed by the control, it calculates the ramp required to move the process from the starting value (current PV) to the desired value (programmed SP) in the time allowed.

Soaks (or dwells) are ramp segments where the target set point is the same as the beginning process value. This allows for multistage ramps without wasting intermediate soak steps. Care must be taken, however, that the process does actually reach the soak value before the soak time starts. If not, the next segment will calculate a slope from the starting PV to the target SP. Depending on your process requirements, this difference may be important. Make sure to test any program for desired results before running production material.

**Do not operate Self Tune while a ramp function is operating. The ramp function will prevent the Self Tune from operating properly. Make sure that all tuning is set up before operating Ramp / Soak.**

## Program Setup

All of the programming for the Ramp / Soak function is done in the Secondary Menu. You may wish to work out your program on paper before going into the programmer menu sequence.

In the Secondary Menu INDEX to **Prog** and make sure that **Prog** is set to **OFF**.

INDEX to **PSEt** and turn **On**.

Skip the **StAt** setting (this is discussed later) and press INDEX to **1ti**.

The following items repeat in the following order: **1ti, 1SP, 1AL** (if alarm is programmed as an event), **2ti, 2SP, 2AL, . . . , 16ti, 16SP, 16AL**. To avoid repetition each item will only be described once.

Set **1ti** to the amount of time you want for the first ramp. This value is in time units (determined by the **tbAS** menu item) from **0** to **9999**. Press **INDEX**.

Set **1SP** to the target value desired for the first ramp. This value is in actual units just like **SP1**. If the control is programmed for temperature, then the SP displays are in temperature. If the control is programmed for some other engineering unit, the SP is set in that unit.

Press INDEX to continue. If Alarm is programmed as an event, then **1AL** will appear. If you wish the Alarm contact to function for this segment, set **1AL** for **On**. If not, set for **OFF**. Press INDEX. If Alarm is not programmed as an event, then **1AL** will not appear. If **1AL** is set to **On**, the Alarm function will be active for the entire period as set in **1ti** above.

Complete setting the segment times (**2ti ... 16ti**), segment set points (**2SP... 16SP**), and event alarm (**2AL ... 16AL**) if it exists.

For unneeded or unused segments set the segment times (**2ti ... 16ti**) to **0**, and set the segment set points (**2SP ... 16SP**) to the same value as the last active set point. Event alarms may be set to indicate "end of run" as you feel necessary.

The last menu item for the ramp / soak function is **PEnd**. **PEnd** determines what the control does when the program has ended. You may choose to have the program repeat (**Loop**), **Hold** the last set point (**16SP**), revert to the local **SP1**, or turn the outputs off (**OoFF**).

It is important to remember that if you want the program to repeat, you must allow the process to return to the same condition that existed when the program first started. Remember that the ramp function calculates the slope by drawing a line from the beginning PV to the ramp target set point. If the PV at the end of the program is different than the PV at the initial start, the ramp will calculate differently.

## Ramp / Soak Operation

When you wish to start the program, enter the Secondary Menu and set the **Prog** menu item to **On**. Return to the HOME position by waiting for the display to time out or by pressing the UP ARROW / ENTER keys and then the DOWN ARROW / INDEX keys.

The home display will read as it normally does. The HOLD indicator over the RUN / HOLD key will be lit. To start the program press INDEX to display **Prog**. Press the UP ARROW key to select **run** and press ENTER. The HOLD indicator will go out, and the program will start.

To suspend the program at any time, INDEX to **Prog**, press the DOWN ARROW key to display **HOLd**, and press ENTER. To resume, INDEX to **Prog**, press the UP ARROW to select run, and press ENTER.

Entering the AUTO / MANUAL mode will also suspend the program operation. The difference is that AUTO / MANUAL also puts the control into manual mode. See Auto / Manual Operation.

The function of the Primary Menu will change depending on the setting of the **StAt** menu item in the Secondary Menu. If **StAt** is **OFF** then the Primary Menu is not changed.

If the **StAt** menu item is set to **On**, then the Primary Menu has three additional information items added before **SP1** appears. The first INDEX item, **###/ ti**, displays the time remaining in the current segment. The next INDEX item, **###/##ti**, displays the total time for the active segment (**1ti...16ti**). The third INDEX item, **###/##SP**, displays the segment set value (**1SP...16SP**). The next INDEX press resumes the normal Primary Menu.

## AUTO / MANUAL OPERATION

The AUTO / MANUAL function allows you to manually adjust the output of the control. This is normally used during process setup or start up. It can also be used for troubleshooting. To switch from AUTO to MANUAL press INDEX to **Auto**. Press the UP ARROW to select **OFF** and press ENTER. The MANual indicator will light and the lower display will change from normal to showing the actual output in percent. The value will be the actual percentage of output that was active when the key was pressed. This is usually known as "bumpless transfer".

If you wish to change the output while in manual, press the UP ARROW or DOWN ARROW keys to change the value, and press ENTER to retain it. It is important to remember that the value of the display can be read as 0 to 100% of the full control output, or 0 to 100% of the range between S1OL and S1OH or S2OL and S2OH. If **APct** is set for **rEAL**, a reading of 50% in MANUAL represents 10 mA. If **APct** is set for **AdJ**, then 50% in MANUAL will represent the mid point in output between **S1OL** and **S1OH**. (Assuming **S1OL** is **20** and **S1OH** is **100** [4 to 20 mA], 50% will represent 12 mA.)

To return to AUTOmatic control, press the ENTER until **Auto** is displayed. Press the DOWN ARROW key to **On**, and press ENTER. The MANual indicator will go out, and the set point will take over. If you want bumpless transfer back to AUTO, while in manual, slowly change the percentage of output until the process variable matches (or at least is close) to the set point. The further away the PV is from the set point, the greater the "bump" or upset there will be in the output.

## OPERATION OF SELF TUNE<sup>®</sup> FUNCTION

Self Tune<sup>®</sup> allows automatic selection of the necessary parameters to achieve best control operation from your CN74000 Series control. If you are using the control output as a simple on-off function (**Out1** set for **OnOF**), none of the following will apply.

### Theory of Operation

The Self Tune function calculates the **Pb1**, **rES**, and **rtE** parameters under the **PID tunE** selection, and the **Fbnd** and **FrtE** parameters, as shown in the Secondary Menu. These values are determined by measuring the response of the process connected to the control. When Self Tune is started, the control temporarily acts as an on-off control. While in this mode the control measures the overshoot and undershoot of the process, and the period of the process (the time from peak value to the next peak value). These measurements are collected over a period that lasts three periods of overshoot and undershoot. The data collected over this time is then compared and calculated into final PID and Fuzzy Logic values. The effect of Fuzzy Logic

on the process is still controlled by the **Fint** (fuzzy intensity) setting. If **Fint** is **0**, the **Fbnd** and **FrtE** will be calculated, but will have no effect. The calculations for the

PID values are the same as used in the standard Ziegler - Nichols equations that have been recognized as standard for decades.

The only modification to the application of the Ziegler - Nichols equations is controlled by the **dFAC** menu item. This menu item controls the amount of rate (derivative) that is applied. A **dFAC** setting of **3** (factory default) or less allows for less damping. A **dFAC** setting of **4** allows for critical damping as set forth in Ziegler - Nichols. A **dFAC** setting of **5** or more allows over damping of the process.

## Program Setup and Operation

In the secondary menu set **tunE** to **SELF**. Skip **LErn** and check to make sure that **dFAC** is set to the desired value. Back up to **LErn** and set to **YES**. The control will begin the Self Tune function. While the Self Tune function is active, the right hand decimal point on the lower display will blink. When Self Tune is complete, the blinking will stop.

After Self Tune is complete, the **tunE** setting automatically switches to **PID**. This allows examination and / or modification of the values calculated. We recommend that you do not change the calculated values unless you have a firm understanding of the parameters involved and their function. For more information on PID tuning, please contact your supplier.

## Option C4, Serial Communication.

The serial communications option allows the control to be written to and read from a remote computer or other similar digital device. Communication is allowed through a RS-485 (Option C4) port.

Wire the communication lines as shown on Page 6. Wiring for the RS-485 is run from control to control in a daisy chain fashion with a termination resistor (120 ohms) across the transmit and receive terminals of the last control in the chain.

Select the control address and communication baud rate with the **Addr** and **bAUD** menu items in the Secure Menu. THE BAUD RATE AND ADDRESS MENU ITEMS WILL TAKE EFFECT ON THE NEXT POWER UP OF THE CONTROL. BE SURE TO POWER CYCLE THE CONTROL BEFORE USING THE NEW BAUD RATE AND ADDRESS.

In operation, you have the option of preventing a write command from the host computer. To prevent the host from writing to the control change the **LORe** menu item in the Secondary Menu to **LOC**. To allow the host to write commands to the control set **LORe** to **rE**. (The host does have the ability to change the **LORe** state, but it is not automatic.)

If your system depends on constant reading or writing to and from the host, you may wish to set the No Activity Timer (**nAt**) to monitor the addressing of the control. When the **LOrE** is set to **rE** and the **nAt** is set to any value other than Off, the control will expect to be addressed on a regular basis. If the control is not addressed in the time set by the value of **nAt**, then the control will display the error message **CHEC LOrE**. To clear the message set **LOrE** to **LOC**.

## CHANGING PROGRAMMING FOR SET POINT 2 AND ALARM

Either Set Point 2 or the Alarm function as the second output of the CN74000. The ordering code determines whether the second output operates as a second set point or alarm.

When the CN74000 second output is programmed as **Control**, **SP2** appears in the Primary Menu and the appropriate **SP2** related menu items appear in the Secondary and Secure Menus. When the CN74000 second output is programmed as **ALarm**, the alarm related menu items appear in the Secondary and Secure Menus.

If you have a control with a second output and wish to change the function of the second output from **ALarm** to **Control** (or vice versa) use the Factory Default procedure.

## FACTORY DEFAULT PROCEDURE

If for any reason you wish to restore the factory settings or change the function of the second output between **ALarm** or **Control** follow the following procedure.

1. Turn off power to control
2. Turn on power to control
3. While control is performing **SELF tEst**, press and hold the INDEX and ENTER keys.
4. The control will display the ROM ID code. Press INDEX.
5. The control will display **FACT dFLt**. If you wish to just restore factory settings, Press ENTER and DOWN ARROW at the same time. The control will be reset to the original factory settings.
6. If you wish to change the operation of the second output, press INDEX.
7. Press INDEX to display **SP2**. Select **Cont** or **AL**.
  - Cont** Uses **SP2** menu items for second output.
  - AL** Uses **ALarm** menu items for second output.
8. Press INDEX to display **OPt**. If your control is equipped with an option, press the UP ARROW to display the option number. If the number is flashing, press ENTER. An enabled option does not flash.
9. Press INDEX to display **ACPt**. Select **YES** or **no**.
  - YES** Changes are accepted and control re-boots.
  - no** Changes are discarded and control re-boots.

## ALARM TYPE AND ACTION



**Caution:** In any critical application where failure could cause expensive product loss or endanger personal safety, a redundant limit controller is required.

The CN74000 Series allows Set Point 1 (and Set Point 2 is equipped) to operate as limit or alarm type outputs. This function is available on all outputs except the proportional current (output type 5). To enable a set point output to act as an alarm or limit, **Out1** (for SP1) or **Out2** (for SP2, if equipped) should be set for **OnOf**.

When **Out1** and / or **Out2** are set to **OnOF**, then the alarm function menu items will appear in the Secure Menu for the selected set point(s).

If the Alarm Programming code in the model number is set to 1, then set point 2 is pre-programmed as an alarm. If the alarm Programming code in the model number is set to 0 and the last number of the model number is not 0 then the second set point is pre-programmed as a cooling output. This programming may be changed in the field with the Factory Default procedure.

When setting **SP2** value (**S2t = AbS**) or the **ALLO** and **ALHi** values (**ALt = AbS**) for an absolute alarm, simply set the value at which the alarm is to occur.

When setting **SP2** value (**S2t = dE**) or the **ALLO** and **ALHi** values (**ALt = dE**) for a deviation alarm, set the difference in value from the Set Point 1 (**SP1**) desired. For example if a low alarm is required to be 5 degrees below the **SP1**, then set **SP2** or **ALLO** to **-5**. If a high alarm is required 20 degrees above the **SP1**, then set **SP2** or **ALHi** to **+20**. If **SP1** is changed, the alarm (**SP2, ALLO, ALHi**) will continue to hold the same relationship as originally set.

When Set Point Power Interrupt (**S#Pi**) or Alarm Power Interrupt (**ALPi**), is programmed **ON** and Set Point Reset (**S#rE**) or Alarm Reset (**ALrE**), is programmed for **Hold**, the alarm will automatically reset after a power failure and on subsequent power restoration if no alarm condition is present.

If Set Point Inhibit (**S#iH**) or Alarm Inhibit (**ALiH**), is selected **ON**, an alarm condition is suspended upon power up until the process value passes through the alarm set point once. Alarm inhibit can be restored as if a power up took place by pressing both the **INDEX** and **ENTER** keys for 5 seconds.



**Warning: Resetting a high set point inhibit will not cause an alarm to occur if the Process Value does not first drop below the high set point value. Do not use the Set Point Inhibit feature if a hazard is created by this action. Be sure to test all combinations of high and low set point inhibit actions before placing control into operation.**

## **Serial Communications Options and Non-volatile Memory**

There are many different types of memory used in computer driven devices. The terms RAM (random access memory) and ROM (read only memory) are a couple with which you may be familiar.

RAM is used in computers to run programs and hold data for a short period of time. This is the memory that is used primarily in PCs. RAM is very fast and can be read and written to over and over again.

ROM is used in computers to hold the 'permanent' programming that allows a PC to start. This memory is 'burned in' to the chip itself and can not be changed. Unlike RAM, however, this memory is permanent. While it can not be changed, it can not lose its programming when power is turned off.

There is a third type of memory that is now currently used to combine the characteristics of both RAM and ROM. This is known as EEPROM (electrically erasable programmable read only memory). While the name may be long and somewhat cryptic, the EEPROM can be erased and re-written many times, and yet hold the programmed data even over long periods of time when the power is off. This is the type of memory that all Omega products use to save the settings your program in your control. The reliability and longevity of the data retention is what allows us to guarantee a 10 year data retention without power.

In normal operation, the control uses RAM, just as any other computerized device. Whenever you make a change to one of the parameters in the control, the set point for example, the new value is written into the EEPROM. This way, if power goes off for whatever reason, when power resumes, the latest settings are preserved. When power is turned on, the data is copied from the EEPROM to the RAM to begin operation.

If EEPROM is such a wonderful thing, you might ask, why bother with RAM? One reason is that RAM is much faster than EEPROM. Faster speed gives you better performance in critical control functions.

Perhaps the most important reason is that EEPROM has a limit to the number of times it can be erased and re-written. Current technology now sets that limit at about one million erase/write cycles. In a dynamic control situation, it may be necessary to update RAM every few milliseconds. EEPROM can not keep up to that pace, and, even if it could, it would be 'used up' in a matter of days.

If you think about how long it would take a million changes to the control programming through the front key pad, you will see that it would take a very long time to get to use up the life of the EEPROM.

Adding one of the computer communications options (e.g. C4, LV) changes the picture. The speed of computer communications is such that hundreds of instructions can be made in less than a minute. In such a situation, the million erase/write cycles could be used up in a couple of months causing the control to fail.

Usually in such a situation, the control is under close observation by the host computer. It may not be necessary, then to the data written to the EEPROM, as it is 'transitory' in nature (changing set points for a ramp/soak sequence for example).

All CN74000 Series controls with communications options made before April 2001 are only able to write to the EEPROM. Controls manufactured after this date have a menu item in the Secure menu ( $5\text{tar}$ ) that allows the serial communications to write to RAM ( $5\text{tar} = \text{no}$ ) with a special write command that allows to EEPROM to be updated or written directly to EEPROM (protocol command 0442).

The factory default is 'write to EEPROM' ( $5\text{tar} = \text{YES}$ ).

If your computer system will be making frequent changes to the control we strongly recommend that you select the 'write to RAM' parameters ( $5\text{tar} = \text{no}$ ). If you are primarily reading from the control, there is no need to change the setting.



**Any instruments equipped with any Serial Communications are limited to one million WRITE cycles to the EEPROM through the Serial Communications Port. Exceeding this limit will generate a FAIL TEST error. There is no limit to the number of times you can READ from this instrument EEPROM.**

Make sure that the software you use does not write too often to the instrument.

If you have any questions regarding how your software works with the instrument(s), contact your System Administrator, Programmer, or Software Supplier.

# MENU SELECTIONS

## PRIMARY MENU

Press **INDEX** to advance to the next menu item. Press **UP ARROW** or **DOWN ARROW** to change the value in the display. Press **ENTER** to retain the value.

If **StAt** (Secondary Menu ) is **On**, the three program status menu items will appear.

**ti** Time remaining for current segment.

**##ti** Total run time for segment ##.

**##SP** Target Set Point for segment ##.

If **StAt** (Secondary Menu ) is **OFF**, the Primary menu operates as follows:

**SP1** Set Point 1 Adjust, Control Point 1.

**SP2** Set Point 2 Adjust (if equipped), Control Point 2.

**Auto** Auto/Manual Station, Select **On** or **OFF**.

**On** Output operation is automatic (normal operation).

**OFF** Output is controlled manually.

See Page 13 for operation of Auto/Manual Station Feature.

If **Prog** is **OFF** in the Secondary Menu, **Prog** (below) will not appear.

**Prog** Ramp/Soak Programmer Run/Hols function, Select **run** or **HoLd**.

**run** Ramp/Soak Programmer is in operation.

**HoLd** Ramp/Soak Programmer is on hold.

## SECONDARY MENU

Hold **UP ARROW & ENTER**. Press **INDEX** to advance to the next menu item. Press **UP ARROW** or **DOWN ARROW** to change the value in the display. Press **ENTER** to retain the value.

If the control is not equipped with alarm, or if the alarm functions (**AL**) are turned **OFF** or programmed as event (**Eunt**), **ALLO** and **ALHi** will not appear.

**ALLo** Alarm Low: The Low Alarm point is usually set below the Set Point. May not appear depending on **AL** setting in **Secure Menu**.

**ALHi** Alarm High: The High Alarm Point is usually set above the Set Point. May not appear depending on **AL** setting in **Secure Menu**.

**Out1** Output selection: Select **OnOf**, **1tP**, **1PuL**, or **ProP**.

**ONOF** A setting of **ONOF** allows the control to operate as a simple on/off mode. This setting forces the control to turn off at set point, and on at the set point plus the differential (**SP\_d**). When selected, the **Out1/OnOF** menu item is followed by **####/SP1d**, and the **tunE**, **Pb**, **rES**, **OFS**, **rtE**, and **ArUP** selections in the Secondary menu and the **S1OL** and **S1OH** selections in the Secure menu are suppressed.

**SP\_d** Set Point On-Off Differential (hysteresis). Select **1** to **9999** (direct acting), or **-1** to **-9999** (reverse acting). This value will be negative for reverse acting set points, and positive for direct acting outputs. Set the value for the amount of difference between the turn off point (set point) and the turn on point. The following drawing shows output behavior for reverse and direct action.

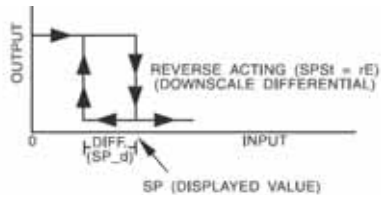
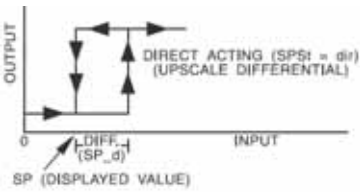

**##tP** Time Proportioning Cycle Time. Select **1tP** to **80tP**.

**1tP** A setting of **1tP** is recommended for solid state outputs (SSR or 15VDC).

**2tP to 80tP** Time Proportioning Control is adjustable in 1 second steps. Recommended for mechanical outputs (relays, solenoids, etc.). For best contact life, a time should be selected as long as possible without causing the process to wander.

**#PuL** Pulsed Time Proportioning Output: Select **1PuL** to **7PuL**. **1PuL** = Linear and **7PuL** = most nonlinear. Changes output linearity for use in cooling applications or for an extremely fast response processes. At the center of the proportional band, a pulse value of 1 provides an output of one second on and one second off (50% output). A pulse value of 2 provides an output of one second on and two seconds off (33% output). Output at center of band equals one second on,  $2^{(\text{pulse value}-1)}$  seconds off.

**ProP** For Current (Code 5) outputs only.

The following menu items apply only if your control is equipped with a second set point (last digit of model number is not zero and Alarm Programming code is zero). If your control does not have a second set point or if the second output is programmed as Alarm, jump to the "tunE" menu on the following pages.

**Out2** Output selection: Select **OnOf**, **2tP**, **2PuL**, or **ProP**.

**ONOF** A setting of **ONOF** allows the control to operate as a simple on/off mode. This setting forces the control to turn off at set point, and on at the set point plus the differential (**SP2d**). When selected, the **Out2/OnOF** menu item is followed by **###/SP2d**, and the **Pb2** selection in the Secondary menu and the **S2OL** and **S2OH** selections in the Secure menu are suppressed.

**SP2d** Set Point On-Off Differential (hysteresis). Select **1** to **9999** (direct acting), or **-1** to **-9999** (reverse acting). This value will be negative for reverse acting set points, and positive for direct acting outputs. Set the value for the amount of difference between the turn off point (set point) and the turn on point. The drawing on the previous page (See **SP1d**) shows output behavior for reverse and direct acting.

**##tP** Time Proportioning Cycle Time. Select **1tP** to **80tP**.

**1tP** A setting of **1tP** is recommended for solid state outputs (SSR or 15VDC).

**2tP to 80tP** Time Proportioning Control is adjustable in 1 second steps. Recommended for mechanical outputs (relays, solenoids, etc.). For best contact life, a time should be selected as long as possible without causing the process to wander.

**#PuL** Pulsed Time Proportioning Output: Select **1PuL** to **7PuL**. **1PuL** = Linear and **7PuL** = most nonlinear. Changes output linearity for use in cooling applications or for an extremely fast response processes. At the center of the proportional band, a pulse value of 1 provides an output of one second on and one second off (50% output). A pulse value of 2 provides an output of one second on and two seconds off (33% output). Output at center of band equals one second on,  $2^{(\text{pulse value}-1)}$  seconds off.

- tunE** Tuning Choice: Select **SELF**, **Pid**, **SLO**, **nor**, or **FAST**.
- SELF** The Controller will evaluate the Process and select the PID values to maintain good control. Active for SP1 only.
- LErn** Select **YES** or **no**
- YES** Start Learning the Process. After the process has been learned the menu item will revert to **no**.
- no** Learning will stay in present mode.
- dFAC** Damping factor, Select **OFF**, **1** to **7**. Sets the ratio of Rate to Reset for the SELF tunE mode. **7** = most Rate. Factory set to **3**. For a fast response process the value should be lowered (less Rate). For a slower process the value should be increased (more Rate).
- Pid** Manually adjust the PID values. PID control consists of three basic parameters, Proportional Band (Gain), Reset Time (Integral), and Rate Time (Derivative).
- Pb1** Proportional Band (Bandwidth). Select **1** to **9999** °F, °C, or counts.
- Pb2** Proportional Band (Bandwidth). Select **1** to **9999** °F, °C, or counts. Appears only if control is equipped with second set point and **Out2** is NOT selected as **ONOF**.
- rES** Automatic Reset Time. Select **OFF**, **0.1** to **99.9** minutes. Select **OFF** to switch to **OFS**.
- OFS** Manual Offset Correction Select **OFF**, **0.1** to **99.9%**. Select **OFF** to switch to **rES**.
- rtE** Rate Time. Select **OFF**, **0.01** to **99.99** minutes, Derivative.
- SLO** PID values are preset for a slow response process.
- nor** PID values are preset for a normal response process.
- FAST** PID values are preset for a fast response process.
- Pid2** Linkage of PID parameters between SP1 and SP2: Select **On** or **OFF**.
- On** Applies SP1 **rEs**, **rtE**, **Fbnd**, and **FrE** terms to SP2 for heat/cool applications.
- OFF** SP2 functions without **rEs**, **rtE**, **Fbnd** and **FrE**. Does not appear if not equipped with second output or if second output is programmed as alarm.
- ArUP** Anti-Reset Windup Feature: Select **On** or **OFF**.
- On** When ArUP is **On** the accumulated Reset Offset value will be cleared to 0% when the process input is not within the Proportional Band.
- OFF** When ArUP is **OFF**, the accumulated Reset Offset Value is retained in memory when the process input is not within the Proportional Band.

- ArtE** Approach Rate Time: Select **OFF**, **0.01** to **99.99** minutes. The function defines the amount of Rate applied when the input is outside of the Proportional Band. The ArtE time and the rtE time are independent and have no effect on each other. To increase damping effect and reduce overshoot set the approach rate time for a value greater than the natural rise time of the process (natural rise time = process value time to set point).
- Fint** Fuzzy Logic Intensity: Select **0** to **100%**. 0% is OFF (disables Fuzzy Logic). The function defines the amount of impact Fuzzy Logic will have on the output. If **Fint** is set to **0**, **Fbnd** and **FrtE** below will not appear.
- Fbnd** Fuzzy Logic Error Band: Select **0** to **4000** °F, °C, or counts. Sets the band width of the Fuzzy Logic. Set **Fbnd** equal to PID proportional band (**Pb1**) for best results. Will not appear if **Fint** is **OFF**.
- FrtE** Fuzzy Logic Rate of Change: Select **0.00** to **99.99** counts/second. For best initial setting, find the count/second change of process value near set point 1 with output ON 100%. Multiply this value by 3. Set **FrtE** to this calculated value. Will not appear if **Fint** is **OFF**.
- PEA** The Peak feature stores the highest input the control has measured since the last reset or Power On. At Power On PEA is reset to the present input. To manually reset the value **PEA** must be in the lower display. Press the **ENTER** key to reset. **PEA** will be reset and display the present input value.
- UAL** The Valley feature stores the lowest input the Instrument has measured since the last reset or Power On. At Power On **UAL** is reset to the present input. To manually reset the value **UAL** must be in the lower display. Press the **ENTER** key. **UAL** will be reset and display the present input value.
- PctO** Percent Output Feature: Select **On** or **OFF**.
- On** When selected **On**, the HOME lower display will indicate the output of the controller in percent. An "P" will appear in the right hand side of the lower display to indicate percent output for SP1. An "O" will appear on the right hand corner of the lower display to represent percent output for SP2, if the control is so equipped. The display will alternate between these values.
- OFF** Percent Output display is disabled.
- Prog** Ramp/Soak Feature: Select **On** or **OFF**
- On** Allows Programmed Ramp/Soak function to be started by the Run/Hold key on the control front panel.
- OFF** Turns Ramp/Soak function **OFF** and resets program to beginning.
- PSEt** Programmer function set. Select **On** or **OFF**.
- OFF** Skip Ramp/Soak Programming. Go to next Secondary Menu Item, In PC on the next page.
- On** Enable Ramp/Soak Programming.

- StAt** Programmer Status Display in the Primary Menu when Prog (above) is On: Select **On** or **OFF**.  
**OFF** The Primary Menu operates as normal.  
**On** The Primary Menu is altered to have the following items inserted before the SP1 menu item: **####/ti** (time remaining in segment), **####/##ti** (total time in active segment), and **####/##SP** (segment target set point).
- tbAS** Ramp/Soak Time Base. Select **1\_S** or **60\_S**.  
**1\_S** Ramp/Soak time base is in 1 second increments. Program time 1ti...16ti is measured in seconds.  
**60\_S** Ramp/Soak time base is in 60 second increments (minutes). Program time 1ti...16ti is measured in minutes.

**The following items repeat in the following order: 1ti, 1SP, 1A1 (if alarm 1 is programmed as an event), 2ti, 2SP, 2A1, . . . , 16ti, 16SP, 16A1. To avoid repetition each item will only be described once.**

- 1ti** Segment Time: Select **0** to **9999** units (minutes if **tbaS** is set to **60\_S**, seconds if **tbaS** is set to **1\_S**).
- 1SP** Segment Set Point: Select as desired.
- 1AL** Segment Alarm Event: Select **On** or **OFF**.  
**On** Alarm is active during segment 1 time (**1ti**).  
**OFF** Alarm is inactive during segment 1 time (**1ti**).
- PEnd** Program End action: Select **Hold** or **OoFF**.  
**Hold** Stay at the Present Set Point (**16SP**).  
**OoFF** Turn Off SP1 and SP2 Outputs at the end of the program.  
**Loop** Repeat program starting at **1ti**.  
**SP1** Revert to **SP1** value.
- InPC** Input Correction: Select **±500** °F, °C, or counts. This feature allows the input value to be changed to agree with an external reference or to compensate for sensor error. **Note:** InPC is reset to zero when the input type is changed, or when decimal position is changed.
- FiLt** Digital Filter: Select **OFF**, **1** to **99**. In some cases the time constant of the sensor, or noise could cause the display to jump enough to be unreadable. A setting of 2 is usually sufficient to provide enough filtering for most cases, (2 represents approximately a 1 second time constant). When the 0.1 degree resolution is selected this should be increased to 4. If this value is set too high, controllability will suffer.
- LPbr** Loop Break Protection: Select **OFF**, **1** to **9999** seconds. If, during operation, the output is minimum (0%) or maximum (100%), and the input moves less than 5°F (3°C) or 5 counts over the time set for LPbr, the **LOOP bAd** message will appear. This condition can also be routed to an Alarm Condition if alarms are present and turned On (see ALbr in the secure menu). The loop break error can be reset by pressing the **ENTER** key when at the LPbr menu item. The **INDEX & ENTER** keys may also be used.

**LOrE** (Option C4, Serial Communications) Local / Remote Status: Select **LOC** or **rE**.

**LOC** The host computer is advised not to send remote commands. Any write commands sent to the controls will be rejected.

**rE** The host computer is allowed to send write commands. If the control is not addressed within the time set in the **nAt** (No Activity Timer, see Secure Menu) the **CHEC LOrE** error message will be displayed.

**Addr** (Option C4, Serial Communications) Control Address: Set from 1 to 3FF. This number (hexadecimal, base 16) must match the address number used by the host computer. Viewed only in this menu. To change this parameter, see **Addr** in the Secure Menu.

### SECURE MENU

Hold **UP ARROW & ENTER** for 5 Seconds. Press **INDEX** to advance to the next menu item. Press **UP ARROW** or **DOWN ARROW** to change the value in the display. Press **ENTER** to retain the value.

**OUTPUTS ARE DISABLED (TURNED OFF) WHILE CONTROL IS IN SECURE MENU.**

**SECr** Security Code: See the Security Level Selection and the Password Table in this manual, in order to enter the correct password.

**InP** Input Type: Select one of the following. Refer to the Input wiring section for the proper wiring.

<b>J-IC</b>	Type "J" Thermocouple
<b>CA</b>	Type "K" Thermocouple
<b>E-</b>	Type "E" Thermocouple
<b>t-</b>	Type "T" Thermocouple
<b>L-</b>	Type "L" Thermocouple
<b>n-</b>	Type "N" Thermocouple
<b>r-13</b>	Type "R" Thermocouple
<b>S-10</b>	Type "S" Thermocouple
<b>b-</b>	Type "B" Thermocouple
<b>C-</b>	Type "C" Thermocouple
<b>P392</b>	100 ohm Platinum (NIST 0.00392 /°C)
<b>n120</b>	120 ohm Nickel
<b>P385</b>	100 ohm Platinum (DIN 0.00385 /°C)
<b>1P38</b>	1000 ohm Platinum (DIN 0.00385 /°C)
<b>Curr</b>	DC Current Input 0.0 to 20.0 or 4.0 to 20.0 mA.
<b>VoLt</b>	DC Voltage Input 0.0 to 5.0 or 1.0 to 5.0 volts.
<b>diFF</b>	DC Voltage Input -10 to +10 mV.
<b>----</b>	Reserved

**OSUP** Zero Suppression: Select **On** or **OFF**. Only with Current and Voltage input types.

**OFF** The input range will start at 0 (zero) Input.

**On** The input range will start at 4.00 mA or 1.00 V.

- Unit** **F, C** or **None**.
- F** °F descriptor is On and temperature inputs will be displayed in actual degrees Fahrenheit.
- C** °C descriptor is On and temperature inputs will be displayed in actual degrees Celsius.
- nonE** °F and °C descriptors will be Off. This is only available with Current and Voltage Inputs.
- dPt** Decimal Point Positioning: Select **0, 0.0, 0.00, or 0.000**. On temperature type inputs this will only effect the Process Value, SP1, SP2, ALLO, ALHi, and InPC. For Current and Voltage Inputs all Menu Items related to the Input will be affected.
- 0** No decimal Point is selected. This is available for all Input Types.
- 0.0** One decimal place is available for Type J, K, E, T, L, RTD's, Current and Voltage Inputs.
- 0.00** Two decimal places is only available for Current and Voltage Inputs.
- 0.000** Three decimal places is only available for Current and Voltage Inputs.
- InPt** Input Fault Timer: Select **OFF, 0.1** to **540.0** minutes. Whenever an Input is out of range (UFL or OFL displayed), shorted, or open the timer will start. When the time has elapsed, the controller will revert to the output condition selected by **InPb** below. If OFF is selected, the Input Fault Timer will not be recognized (time =infinite).
- InPb** Input Fail Action: Select **FAIL, AVE, or PrE**. When the Input is out of range (UFL or OFL displayed) and the Input timer (**InPt**) time has elapsed, the controller will revert to the selected condition.
- FAIL** Outputs are disabled (go to 0% output).
- AVE** The outputs will hold at the last known average percentage of output.
- PrE** The outputs will maintain a preprogrammed percentage of output as specified in **PrE1** and **PrE2**.
- PrE1** Preset output for Set Point 1. Select 0 to 100%.
- PrE2** Preset output for Set Point 2. Select 0 to 100%.
- APCt** Manual and PctO display adjustment. Select **rREAL** or **Adj**.
- rREAL** Manual display will display output 0 to 100% relative to actual range of the output.
- Adj** Manual display will display output 0 to 100% relative to the **S#OL** and **S#OH** settings.
- SEnC** Sensor Rate of Change: Select **OFF, 1** to **4000** °F, °C, or counts per 1 second period. This value is usually set to be slightly greater than the fastest process response expected during a 1 second period, but measured for at least 2 seconds. If the process is faster than this setting, the SEnC bAd error message will appear. The outputs will then be turned off. This function can be used to detect a runaway condition, or speed up detection of an open thermocouple. Use the **INDEX & ENTER** keys to reset.

**SCAL** Scale Low: Select **100** to **9999** counts below **SCAH**. The total span between **SCAL** and **SCAH** must be within 11998 counts. Maximum setting range is -1999 to +9999 counts. For Current and Voltage inputs, this will set the low range end. Viewable only for Thermocouple and RTD ranges.

**SCAH** Scale High: Select **100** to **9999** counts above **SCAL**. The total span between **SCAL** and **SCAH** must be within 11998 counts. Maximum setting range is -1999 to +9999 counts. For Current and Voltage inputs, this will set the high range end. Viewable only for Thermocouple and RTD ranges.

**SPL** Set Point Low: Select from the lowest input range value to **SPH** value. This will set the minimum SP1 or SP2 value that can be entered. The value for SP1 or SP2 will not stop moving when this value is reached.

**SPH** Set Point High: Select from the highest input range value to **SPL** value. This will set the maximum SP1 or SP2 value that can be entered. The value for SP1 or SP2 will not stop moving when this value is reached.

**SP10** Set Point 1 Output Select: Select **OutA** or **Outb**.

**OutA** Set Point 1 is routed through Output A, Set Point 2 (if equipped) is routed through Output B. Setting is forced to OutA if control is equipped with single output or if second output is programmed as alarm.

**Outb** Set Point 1 is routed through Output B, Set Point 2 (if equipped) is routed through Output A.

**S1St** Set Point 1 State: Select **dir** or **rE**.

**dir** Direct Action. As the input increases the output will increase. Most commonly used in cooling processes.

**rE** Reverse Action. As the input increases the output will decrease. Most commonly used in heating processes.

If **Out1** is set for **##tP**, **#PUL**, or **ProP**, then **S1OL** and **S1OH** (following) appear. If **Out1** is set for **ONOF**, then skip to **S1rE**.

**S1OL** Set Point Output Low Limit: Select **0** to **100%** but not greater than **S1OH**. This item limits the lowest output value. This is useful for adding a bias to the process when needed. Factory set to **0** for output codes 1,2, and 3. Factory set to **20** for output code 5 (20% output equals 4 mA output).

**S1OH** Set Point 1 Output High Limit: Select **0** to **100%** but not less than **S1OL** for output codes 1, 2, or 3. Select **0** to **102%** but not less than **S1OL** for output code 5. This item allows setting the maximum output limit. This is useful with processes that are overpowered. Adjustment to 102% allows setting current output to force a full on condition for output devices which do not have bias adjustments. Factory set to **100** for all output codes.

If **Out1** is set for **##tP**, **#PUL**, or **ProP**, then skip to **S1LP** on next page.

**S1rE** Set Point 1 Reset. Select **OnOF** or **Hold**.

**OnOF** Control will automatically reset when process passes back through **SP1d**.

**HoLd** Manual Reset. Reset (acknowledge) by simultaneously pressing the **INDEX & DOWN ARROW** keys for 5 seconds.

**S1Pi** Set Point 1 Power Interrupt. Select **On** or **OFF**.  
**On** Alarm Power Interrupt is **On**. Control will automatically reset on power-up if no alarm condition exists.  
**OFF** Alarm Power Interrupt is **OFF**. Control will power-up in alarm condition regardless of condition of process.

**S1iH** Set Point 1 Inhibit: Select **On** or **OFF**.  
**On** Alarm Inhibit is **On**. Alarm action is suspended until the process value first enters a non-alarm condition.  
**OFF** Alarm Inhibit is **OFF**.

**S1LP** Set Point Lamp: Select **O on** or **OoFF**.  
**O on** Lamp ON when Output is ON.  
**OoFF** Lamp OFF when Output is ON.

**If your control is not equipped with a second output or if the second output is programmed as an alarm, then proceed to the alarm section (next page).**

**S2t** Set Point 2 type: Select **Abs** or **dE**.  
**AbS** Absolute **SP2**. **SP2** is independent of **SP1**, and may be set anywhere between the limits of **SPL** and **SPH**.  
**dE** Deviation **SP2**. **SP2** is set as a deviation from **SP1**, and allows **SP2** to retain its relationship with **SP1** when **SP1** is changed (tracking **SP2**).

**S2St** Set Point 2 State: Select **dir** or **rE**.  
**dir** Direct Action. As the input increases the output will increase. Most commonly used in cooling processes.  
**rE** Reverse Action. As the input increases the output will decrease. Most commonly used in heating processes.

If **Out2** is set for **##tP**, **#PUL**, or **ProP**, then **S2OL** and **S2OH** (following) appear. If **Out2** is set for **ONOF**, then skip to **S2rE**.

**S2OL** Set Point Output Low Limit: Select **0** to **100%** but not greater than **S2OH**. This item limits the lowest output value. This is useful for adding a bias to the process when needed. Factory set to **0** for output codes 1, 2, and 3. Factory set to **20** for output code 5 (20% output equals 4 mA output).

**S2OH** Set Point 1 Output High Limit: Select **0** to **100%** but not less than **S2OL** for output codes 1, 2, or 3. Select **0** to **102%** but not less than **S2OL** for output code 5. This item allows setting the maximum output limit. This is useful with processes that are overpowered. Adjustment to 102% allows setting current output to force a full on condition for output devices which do not have bias adjustments. Factory set to **100** for all output codes.

- S2rE** Set Point 2 Reset. Select **OnOF** or **Hold**.
- OnOF** Control will automatically reset when process passes back through **SP2d**.
- HoLd** Manual Reset. Reset (acknowledge) by simultaneously pressing the **INDEX & DOWN ARROW** keys for 5seconds.
- S2Pi** Set Point 2 Power Interrupt. Select **On** or **OFF**.
- On** Alarm Power Interrupt is **On**. Control will automatically reset on power-up if no alarm condition exists.
- OFF** Alarm Power Interrupt is **OFF**. Control will power-up in alarm condition regardless of condition of process.
- S2iH** Set Point 2 Inhibit: Select **On** or **OFF**.
- On** Alarm Inhibit is **On**. Alarm action is suspended until the process value first enters a non-alarm condition.
- OFF** Alarm Inhibit is **OFF**.
- S2LP** Set Point 2 Lamp: Select **O on** or **OoFF**.
- O on** Lamp ON when Output is ON.
- OoFF** Lamp OFF when Output is ON.

The following menu item applies only to the alarm when programmed.

- AL** Alarm function: Select **OFF**, **Lo**, **Hi**, **HiLo**, or **Evnt**.
- OFF** Alarm is disabled. No Alarm menu items appear in the Secondary or Secure menus.
- Lo** Low Alarm Only. **ALLo** appears in the Secondary Menu.
- Hi** High Alarm Only. **ALHi** appears in the Secondary Menu.
- HiLo** High and Low Alarms. Both **ALLo** and **ALHi** appear in the Secondary Menu, and share the same Alarm Relay output.
- Evnt** Alarm is controlled by the Ramp/Soak program function. See pages 11-13 (**#AL**) for further information.

If **AL** is set to **OFF** and the control is not equipped with options, the Secure Menu ends. If **AL** is set to **OFF** or the second output is programmed as control, and the control is equipped with options, proceed to **Addr**.

If **AL** is set to **Evnt**, go to **ALSt**

- ALt** Alarm Type: Select **AbS** or **dE**
- AbS** Absolute Alarm that may be set anywhere within the values of **SCAL** and **SCAH** and is independent of **SP1**.
- dE** Deviation Alarm that may be set as an offset from **SP1**. As **SP1** is changed the Alarm Point will track with **SP1**. A deviation alarm will also track any active ramp or soak set point.

- ALrE** Alarm Reset: Select **OnOF** or **Hold**.  
**OnOF** Automatic Reset.  
**Hold** Manual Reset. Reset (acknowledge) by simultaneously pressing the **INDEX & DOWN ARROW** keys for 5 seconds.
- ALPi** Alarm Power Interrupt: Select **On** or **OFF**.  
**On** Alarm Power Interrupt is **On**.  
**OFF** Alarm Power Interrupt is **OFF**.
- ALiH** Alarm Inhibit: Select **On** or **OFF**.  
**On** Alarm Inhibit is **On**. Alarm action is suspended until the process value first enters a non-alarm condition.  
**OFF** Alarm Inhibit is **OFF**.
- ALSt** Alarm Output State: Select **CLOS** or **OPEn**.  
**CLOS** Closes Contacts at Alarm Set Point.  
**OPEn** Opens Contacts at Alarm Set Point.
- ALLP** Alarm Lamp: Select **O on** or **OoFF**.  
**O on** Alarm Lamp is ON when alarm contact is closed.  
**OoFF** Alarm Lamp is OFF when alarm contact is closed.
- ALLb** Alarm Loop Break. Select **On** or **OFF**.  
**On** Loop Break Condition will cause an Alarm Condition.  
**OFF** Loop Break will not affect the Alarm Condition.
- Addr** *(Option C4, Serial Communications) Control Address: Set from **1** to **3FF**. This number (hexadecimal, base 16) must match the address number used by the host computer.*
- bAUd** *(Option C4, Serial Communications) Communication Baud Rate: Select **300, 1200, 2400, 4800, 9600, or 19200**. This number must match the baud rate used by the host computer.*
- nAt** *(Option C4, Serial Communications) No Activity Timer: Set from **OFF** or **1** to **99** minutes.*  
**1 - 99** *Maximum time between host computer accesses. If timer counts to 0, CHEC/LorE will be displayed.*  
**OFF** *No Activity Timer function is disabled.*
- Stor** *(Option C4, Serial Communications) Store to EEPROM: Select **YES** or **no**. (See additional information on page 21).*  
**YES** *Menu Items changes made through the Serial Communications are stored directly to the EEPROM.*  
**no** *Menu items changes made through the Serial Communications are stored directly in RAM.*

## SPECIFICATIONS

**Selectable Inputs:** Thermocouple, RTD, DC Voltage, or DC Current selectable.

**Input Impedance:**

Thermocouple = 3 megohms minimum. RTD current = 200 $\mu$ A.  
Current = 10 ohms. Voltage = 5000 ohms.

**Sensor Break Protection:** De-energizes control output to protect system after customer set time. (See **InPt** in Secondary Menu.)

**Set Point Range:** Selectable (See Range Chart Page 39).

**Display:** Two 4 digit, 7 segment 6.35 mm (0.25") high LEDs.

**Control Action:** Reverse (usually heating), Direct (usually cooling) selectable.

**Proportional Band:** 1 to 9999 °F, °C, or counts.

**Reset Time (Integral):** Off or 0.1 to 99.9 minutes.

**Rate Time (Derivative):** Off or 0.01 to 99.99 minutes.

**Cycle Rate:** 1 to 80 seconds.

**On - Off Differential:** Adjustable 1° F, 1° C, or 1 count to full scale in 1° F, 1° C, or 1 count steps.

**Alarm On - Off Differential:** 1° F, 1° C, or 1 count.

**Fuzzy Percent:** 0 to 100%.

**Fuzzy Rate:** Off or 0.01 to 99.99 minutes.

**Fuzzy Band:** Off or 1 to 4000 °F, °C, or counts.

**Accuracy:**  $\pm 0.25\%$  of span,  $\pm 1$  least significant digit.

**Resolution:** 1 degree or 0.1 degree, selectable.

**Line Voltage Stability:**  $\pm 0.05\%$  over the supply voltage range.

**Temperature Stability:** 4 $\mu$ V/°C (2.3  $\mu$ V/°F) typical, 8  $\mu$ V/°C (4.5  $\mu$ V/°F) maximum  
(100 ppm / °C typical, 200 ppm / °C maximum).

**Common Mode Rejection:** 140 db minimum at 60 Hz.

**Normal Mode Rejection:** 65 db typical, 60 db at 60 Hz.

**Isolation:**

**Relay outputs:** 1500 Vac to all other inputs and outputs.

**SP1 Switched Voltage outputs:** Non-isolated, shares common ground with input.

**Supply Voltage:** 100 to 240 Vac, nominal., +10 -15%, 50 to 400 Hz. single phase;  
132 to 240 Vdc, nominal., +10 -20%.

**Supply Voltage (LV):** 12 to 24 Vdc, Vac 40-400 Hz,  $\pm 20\%$ .

**Power Consumption:** 5VA maximum.

**Operating Temperature:** -10 to +55 °C (+14 to 131 °F).

**Storage Temperature:** -40 to +80 °C (-40 to 176 °F).

**Humidity Conditions:** 0 to 90% up to 40 °C non-condensing, 10 to 50% at 55 °C non-condensing.

**Memory Backup:** Nonvolatile memory. No batteries required.

**Control Output Ratings:**

**Relay (Output A, Output B):** SPST, 3 A @ 240 Vac resistive; 1.5A@240 Vac inductive; 1/10 HP @ 120 Vac.

**Switched Voltage (non-isolated, Output A, Output B):** 5 Vdc @20 mA.

**Panel Cutout:** 45.0 mm x 22.2 mm (1.772" x 0.874").

**Depth Behind Mounting Surface:** 111.6 mm (4.395").

**Weight:** 114 g (4 oz).

**Agency Approvals:** CE.

**Front Panel Rating:** Type 4, IP66.

## DIAGNOSTIC ERROR MESSAGES

DISPLAY	MEANING	SP OUTPUTS	ACTION REQUIRED
<b>UFL</b> or <b>OFL</b>	Underflow or Overflow: Process value has exceeded input range ends	Set point outputs active Alarm active.	Input signals may normally go above or below range ends. If not, check input and correct.
	<b>UFL</b> or <b>OFL</b> will sequence to display one of these messages if the <b>InPt</b> is set for a time value.	Set point outputs inactive Alarm active.	To reset use the <b>INDEX</b> and <b>ENTER</b> keys. When <b>InPt</b> (input fault timer) has been set for a time, the outputs will be turned off after the set time. Setting the time to OFF causes the outputs to remain active, however <b>UFL</b> or <b>OFL</b> will still be displayed.
<b>bAd</b> <b>InP</b>	For RTD inputs RTD is open or shorted.		Correct or replace sensor. To reset use the <b>INDEX &amp; ENTER</b> keys.
<b>OPEn</b> <b>InP</b>	For THERMOCOUPLE inputs thermocouple is open.		Correct or replace sensor. To reset use the <b>INDEX &amp; ENTER</b> keys.
<b>LOOP</b> <b>bAd</b>	The sensor may be defective, heater fuse open, heater open, or the final power output device is bad.	Set point outputs inactive Alarm active.	Correct or replace sensor, or any element in the control loop that may have failed. Correct the problem, and reset the control by pressing <b>INDEX</b> and <b>ENTER</b> keys, or <b>INDEX</b> to <b>LPbr</b> and press <b>ENTER</b> .
<b>SEnC</b> <b>bAd</b>	Sensor Rate of Change exceeded the programmed limits set for <b>SEnC</b> .	Set point outputs inactive Alarm active.	Check for the cause of the error. The value setting may be too slow for the process, or the sensor is intermittent. Correct the problem and press <b>INDEX</b> and <b>ENTER</b> to reset.
<b>CHEC</b> <b>CAL</b>	Check calibration appears as an alternating message if the instrument calibration nears tolerance edge.	Set point outputs active Alarm active.	Remove the instrument for service and / or recalibration. To reset use the <b>INDEX &amp; ENTER</b> keys.
	Check calibration appears as an alternating message if the instrument calibration exceeds specification.	Set point outputs inactive Alarm active.	Remove the instrument for service and / or recalibration. To reset use the <b>INDEX &amp; ENTER</b> keys.

## DIAGNOSTIC ERROR MESSAGES

DISPLAY	MEANING	SP OUTPUTS	ACTION REQUIRED
<b>No display lighted</b>	Display is blank. Instrument is not getting power, or the supply voltage is too low.	Set point outputs inactive Alarm inactive.	Check that the power supply is on, or that the external fuses are good.
<b>FAIL tEst</b>	Fail test appears upon power up if the internal diagnostics detect a failure. This message may occur during operation if a failure is detected. Displays flash.	Set point outputs inactive Alarm inactive.	The display alternate between FAIL tEst and one of the following messages: <b>FACT dFLt</b> : Memory may be corrupted. Press the <b>ENTER</b> key and the <b>DOWN ARROW</b> key to start default factory procedure. Recheck controller programming. <b>rEt FACT</b> : Unrecoverable error, return to factory for service.
<b>CHEC SP1, CHEC SP2, CHEC 1SP, ..., CHEC 16SP</b>	This message will appear upon power up if SP1, SP2, #SP1, or ##SP is set outside of the <b>SPL</b> or <b>SPH</b> values.	Set point outputs inactive Alarm active.	Correct the <b>SP1, etc.</b> or adjust the <b>SPL</b> or <b>SPH</b> values by programming new values
<b>CHEC SPL or CHEC SPH</b>	This message appears at power up if <b>SPL</b> or <b>SPH</b> values are programmed outside the input range ends.	Set point outputs inactive Alarm inactive.	Correct the <b>SPL</b> or <b>SPH</b> values by programming new values.
<b>CHEC rSpt</b>	This message appears if the analog remote set point signal is out of range.	Set point outputs active Alarm inactive.	The control will revert to SP1. Correction of the analog signal allows the control to return to the remote.
<b>CHEC LorE</b>	This message appears if the Serial Communications has timed out.	Set point outputs active Alarm active.	Restore the communications line and switch the LorE to LOC.
<b>ArEA (Alternates with PV when near)</b>	This message appears if the ambient temperature of the control is out of range or RJC sensor is broken	Set point outputs active Alarm active.	Correct the ambient temperature conditions. Ventilate the area of the cabinet or check for clogged filters. If RJC broken, return to factor for service.

## Input Ranges (Field Selectable)

### Thermocouple Types

Input Type	Type J or L*	Type K*	Type T*	Type E*
Range 1° F 1° C	-100 to +1600 -73 to +871	-200 to +2500 -129 to +1371	-350 to +750 -212 to +398	-100 to +1800 -73 to +982
Input Type	Type R	Type S	Type B	Type C
Range 1° F 1° C	0 to 3200 -17 to +1760	0 to 3200 -17 to +1760	+75 to 3308 +24 to 1820	0 to 4208 -17 to 2320
Input Type	Type N*	* These Input Types can be set for 0.1° display. If temperature goes above 999.9° or less than -199.9° the display will return the whole degree resolution.		
Range 1° F 1° C	-100 to +2372 -73 to +1300			

### RTD Types

Input Type	100 Ohm Platinum 0.00385 DIN Curve*	100 Ohm Platinum 0.00392 Nist Curve*	120 Ohm Nickel 0.00628 US Ind. Curve*	1000 Ohm Platinum 0.00385 Nist Curve*
Range 1° F 1° C	-328 to +1607 -200 to +875	-328 to +1607 -200 to +875	-112 to +608 -80 to +320	-328 to +1607 -200 to +875

## **Process Input Types**

The 0 to 20 mA<sub>dc</sub>, 4 to 20 mA<sub>dc</sub>, 0 to 10 V<sub>dc</sub>, 2 to 10 V<sub>dc</sub>, and -10 to +10 mV<sub>dc</sub> inputs are fully scalable from a minimum of 100 counts span placed anywhere within the range of -1999 to +9999. Decimal point position is adjustable from zero places (9999), tenths (999.9), hundredth (99.99), or thousands (9.999).

## WARRANTY/DISCLAIMER

OMEGA ENGINEERING, INC. warrants this unit to be free of defects in materials and workmanship for a period of **13 months** from date of purchase. OMEGA's WARRANTY adds an additional one (1) month grace period to the normal **one (1) year product warranty** to cover handling and shipping time. This ensures that OMEGA's customers receive maximum coverage on each product.

If the unit malfunctions, it must be returned to the factory for evaluation. OMEGA's Customer Service Department will issue an Authorized Return (AR) number immediately upon phone or written request. Upon examination by OMEGA, if the unit is found to be defective, it will be repaired or replaced at no charge. OMEGA's WARRANTY does not apply to defects resulting from any action of the purchaser, including but not limited to mishandling, improper interfacing, operation outside of design limits, improper repair, or unauthorized modification. This WARRANTY is VOID if the unit shows evidence of having been tampered with or shows evidence of having been damaged as a result of excessive corrosion; or current, heat, moisture or vibration; improper specification; misapplication; misuse or other operating conditions outside of OMEGA's control. Components in which wear is not warranted, include but are not limited to contact points, fuses, and triacs.

**OMEGA is pleased to offer suggestions on the use of its various products. However, OMEGA neither assumes responsibility for any omissions or errors nor assumes liability for any damages that result from the use of its products in accordance with information provided by OMEGA, either verbal or written. OMEGA warrants only that the parts manufactured by the company will be as specified and free of defects. OMEGA MAKES NO OTHER WARRANTIES OR REPRESENTATIONS OF ANY KIND WHATSOEVER, EXPRESSED OR IMPLIED, EXCEPT THAT OF TITLE, AND ALL IMPLIED WARRANTIES INCLUDING ANY WARRANTY OF MERCHANTABILITY AND FITNESS FOR A PARTICULAR PURPOSE ARE HEREBY DISCLAIMED. LIMITATION OF LIABILITY: The remedies of purchaser set forth herein are exclusive, and the total liability of OMEGA with respect to this order, whether based on contract, warranty, negligence, indemnification, strict liability or otherwise, shall not exceed the purchase price of the component upon which liability is based. In no event shall OMEGA be liable for consequential, incidental or special damages.**

**CONDITIONS:** Equipment sold by OMEGA is not intended to be used, nor shall it be used: (1) as a "Basic Component" under 10 CFR 21 (NRC), used in or with any nuclear installation or activity; or (2) in medical applications or used on humans. Should any Product(s) be used in or with any nuclear installation or activity, medical application, used on humans, or misused in any way, OMEGA assumes no responsibility as set forth in our basic WARRANTY/ DISCLAIMER language, and, additionally, purchaser will indemnify OMEGA and hold OMEGA harmless from any liability or damage whatsoever arising out of the use of the Product(s) in such a manner.

## RETURN REQUESTS/INQUIRIES

Direct all warranty and repair requests/inquiries to the OMEGA Customer Service Department. **BEFORE RETURNING ANY PRODUCT(S) TO OMEGA, PURCHASER MUST OBTAIN AN AUTHORIZED RETURN (AR) NUMBER FROM OMEGA'S CUSTOMER SERVICE DEPARTMENT (IN ORDER TO AVOID PROCESSING DELAYS).** The assigned AR number should then be marked on the outside of the return package and on any correspondence.

The purchaser is responsible for shipping charges, freight, insurance and proper packaging to prevent breakage in transit.

FOR **WARRANTY** RETURNS, please have the following information available BEFORE contacting OMEGA:

1. Purchase Order number under which the product was PURCHASED,
2. Model and serial number of the product under warranty, and
3. Repair instructions and/or specific problems relative to the product.

FOR **NON WARRANTY** REPAIRS, consult OMEGA for current repair charges. Have the following information available BEFORE contacting OMEGA:

1. Purchase Order number to cover the COST of the repair,
2. Model and serial number of the product, and
3. Repair instructions and/or specific problems relative to the product.

OMEGA's policy is to make running changes, not model changes, whenever an improvement is possible. This affords our customers the latest in technology and engineering.

OMEGA is a registered trademark of OMEGA ENGINEERING, INC.

© Copyright 2006 OMEGA ENGINEERING, INC. All rights reserved. This document may not be copied, photocopied, reproduced, translated, or reduced to any electronic medium or machine-readable form, in whole or in part, without the prior written consent of OMEGA ENGINEERING, INC.

# Where Do I Find Everything I Need for Process Measurement and Control? **OMEGA...Of Course!** *Shop online at [omega.com](http://omega.com)*

## **TEMPERATURE**

- ☑ Thermocouple, RTD & Thermistor Probes, Connectors, Panels & Assemblies
- ☑ Wire: Thermocouple, RTD & Thermistor
- ☑ Calibrators & Ice Point References
- ☑ Recorders, Controllers & Process Monitors
- ☑ Infrared Pyrometers

## **PRESSURE, STRAIN AND FORCE**

- ☑ Transducers & Strain Gages
- ☑ Load Cells & Pressure Gages
- ☑ Displacement Transducers
- ☑ Instrumentation & Accessories

## **FLOW/LEVEL**

- ☑ Rotameters, Gas Mass Flowmeters & Flow Computers
- ☑ Air Velocity Indicators
- ☑ Turbine/Paddlewheel Systems
- ☑ Totalizers & Batch Controllers

## **pH/CONDUCTIVITY**

- ☑ pH Electrodes, Testers & Accessories
- ☑ Benchtop/Laboratory Meters
- ☑ Controllers, Calibrators, Simulators & Pumps
- ☑ Industrial pH & Conductivity Equipment

## **DATA ACQUISITION**

- ☑ Data Acquisition & Engineering Software
- ☑ Communications-Based Acquisition Systems
- ☑ Plug-in Cards for Apple, IBM & Compatibles
- ☑ Datalogging Systems
- ☑ Recorders, Printers & Plotters

## **HEATERS**

- ☑ Heating Cable
- ☑ Cartridge & Strip Heaters
- ☑ Immersion & Band Heaters
- ☑ Flexible Heaters
- ☑ Laboratory Heaters

## **ENVIRONMENTAL MONITORING AND CONTROL**

- ☑ Metering & Control Instrumentation
- ☑ Refractometers
- ☑ Pumps & Tubing
- ☑ Air, Soil & Water Monitors
- ☑ Industrial Water & Wastewater Treatment
- ☑ pH, Conductivity & Dissolved Oxygen Instruments