

OMEGA® TEST GAUGES—TYPE T

HIGH ACCURACY AND MONEL® WETTED PARTS

4½, 6, 8½" DIALS

PGT Series

Starts at
\$390



Optional†

Monel Wetted
Parts on
All Ranges

- ✓ High Accuracy: 0.25%
- ✓ Stem and Panel Mount
- ✓ Mirrored Scale
- ✓ Monel® Wetted Parts
- ✓ 4½, 6, or 8½" Dials

The OMEGA® test gauge line consists of highly accurate gauges designed for use in instrument shops, plants of all types, and laboratories throughout industry. Most models provide sustained accuracy to 0.25% full scale. Performance, reliability, and precision measurement are coupled with consistency in meeting the demanding service needs of numerous test gauge applications.

OMEGA® test gauges are used as master reference gauges, in test stand measurements, for production inspection, and for verifying the accuracy of general service gauges.

The gauge dial has a stainless steel mirror ring for pointer reflection, which prevents parallax error. This mirror surface reflects the pointer in any position and allows the gauge to be read with great accuracy. The lightweight, friction-adjustable balanced pointer with knife-edge tip ensures reading to the smallest subdivision. The accented dial graduations have a true width equivalent to 0.25% tolerance for quick and accurate gauge checking.

PGT-85L-100, \$745,
shown smaller than
actual size. See next
page for dimensions.



PGT-60B-100, back mount, \$480,
shown smaller than actual size.
See next page for dimensions.



PGT-45L-100, stem or flush
mount, \$390, shown smaller
than actual size. See next
page for dimensions.

Warning: To prevent misapplication, all gauge components should be chosen with an eye to the media and ambient operating conditions to which they will be exposed. Improper application can be detrimental to the gauge, causing failure and possible personal injury and property damage.

† Refer to the accessories chart on page G-62 for NIST calibration ordering information.

TEST GAUGES—HIGH ACCURACY WITH MONEL® WETTED PARTS

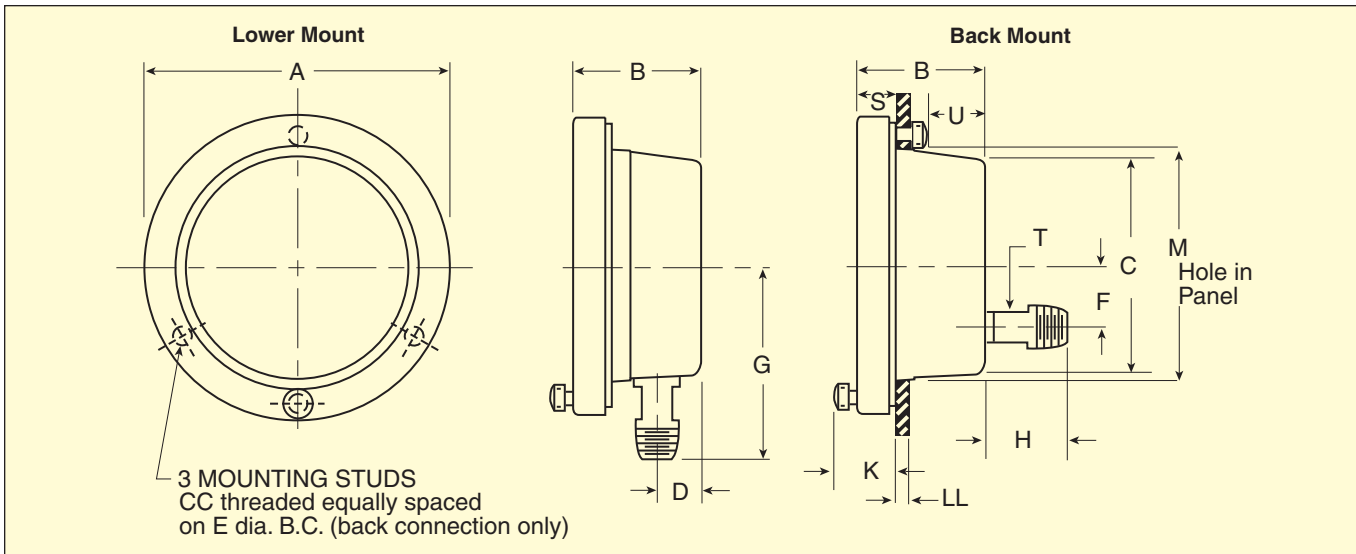

Dimensions: mm (in)

DIAL SIZE	A	B	C	D	E	F	G	H	K	M	S&T	U	CC	LL
4½"	155 (6⅜)	73 (2⅞)	121 (4¾)	30 (1⅙)	137 (5⅝)	41 (1⅝)	100 (3⅚)	35 (1⅝)	34 (1⅜)	124 (4⅞)	16 (⅝)	19 (¾)	#10-24	3 to 13 (⅙ to ½)
6"	192 (7⅝)	73 (2⅞)	121 (4¾)	30 (1⅙)	178 (7)	41 (1⅝)	114 (4½)	35 (1⅝)	34 (1⅜)	165 (6½)	16 (⅝)	19 (¾)	¼-20	3 to 13 (⅙ to ½)
8½"	257 (10⅙)	73 (2⅞)	121 (4¾)	30 (1⅙)	244 (9⅝)	41 (1⅝)	152 (6)	35 (1⅝)	34 (1⅜)	229 (9)	16 (⅝)	19 (¾)	¼-20	3 to 13 (⅙ to ½)

SPECIFICATIONS

Case: Solid aluminum with epoxy-coated black finish

Window: Glass

Movement: Stainless steel

Bourdon Tube: Monel

Connection: Monel

Fitting: ½ NPT

Dial: Externally adjustable, aluminum, white background, black graduations and polished mirror band

Mounting:

Stem: Lower connection

Panel or Stem: Back connection

Accuracy: 0.25% FS

Ring:

Lower Connection Model:

Threaded aluminum

Back Connection Model: Mounting flange, hinged cover ring secured by knurled screw

Safety Features: Solid front with pressure relief back

Media Temperature: 66°C (150°F)

[models will withstand continuous temperature up to 177°C (350°F), but there will be discoloration of case and dial face]

Temperature Compensation:

0.005% FS/°F



PGT-45L-100, stem or flush mount, \$390, shown smaller than actual size. See dimensions above.

Ordering Example:

1. Pressure Gauge:

Test Type

2. Dial Size: 4½"

3. Connection: Lower (L) or Back (B)

4. Range Code: See p. G-62

PGT-45 □ - Range Code

HOW TO ORDER TYPE T TEST GAUGES

DIAL DIA.	MODEL NO.	CONNECTION	PRICE
4½"	PGT-45L-[*]	Lower	\$390
	PGT-45B-[*]	Back	390
6"	PGT-60L-[*]	Lower	480
	PGT-60B-[*]	Back	480
8½"	PGT-85L-[*]	Lower	745
	PGT-85B-[*]	Back	745

[*] Insert range code from table below. To order cleaned for oxygen service, add suffix "X6B" to model number and \$65. Note: Precision test gauges cannot be oil filled. **Ordering Example:** PGT-45B-300, test gauge with 4½" dial, back connection, 0 to 300 psi range, \$390.

Standard psi Ranges Type T

 MOST POPULAR MODELS HIGHLIGHTED!

RANGE CODE	RANGE	FIGURE & TAB INTERVAL	4½" DIAL	6" DIAL	8½" DIAL
			MINOR GRAD	MINOR GRAD	MINOR GRAD
15	0/15	1	0.05	0.05	0.02
30	0/30	2.5	0.1	0.1	0.05
60	0/60	5	0.2	0.1	0.1
100	0/100	5	0.5	0.2	0.2
150	0/150	10	0.5	0.5	0.2
200	0/200	10	0.5	0.5	0.5
300	0/300	25	1	1	0.5
400	0/400	25	1	1	1
600	0/600	50	2	2	1
800	0/800	50	2	2	2
1000	0/1000	50	5	2	2
1500	0/1500	100	5	5	2
2000	0/2000	100	10	5	5
3000	0/3000	250	10	10	5
5000	0/5000	500	20	10	10
10,000	0/10,000	500	50	20	20

VACUUM

30V	30/0" Hg	2.5	0.1	0.1	0.05
-----	----------	-----	-----	-----	------

COMPOUND

RANGE CODE	RANGE		FIGURE		4½" DIAL		6" DIAL		8½" DIAL	
	INCHES MERCURY	psi	inHg	psi	inHg	psi	inHg	psi	inHg	psi
30V/15	30 inHg Vac	0/15 psi	5	3	0.2	0.1	0.2	0.1	0.1	0.05
30V/30	30 inHg Vac	0/30 psi	5	5	0.5	0.2	0.2	0.1	0.2	0.1
30V/60	30 inHg Vac	0/60 psi	5	5	0.5	0.2	0.5	0.2	0.5	0.2
30V/100	30 inHg Vac	0/100 psi	10	5	1	0.5	0.5	0.5	0.5	0.2
30V/150	30 inHg Vac	0/150 psi	10	10	1	0.5	1	0.5	0.5	0.5
30V/200	30 inHg Vac	0/200 psi	30	20	2	1	1	0.5	1	0.5
30V/300	30 inHg Vac	0/300 psi	30	20	2	1	2	1	1	0.5
30V/400	30 inHg Vac	0/400 psi	30	20	5	2	2	1	2	1

See the following page for custom and metric ranges.

ACCESSORIES

MODEL NO.	PRICE	DESCRIPTION
EI-CAL-3-PRESSURE†	\$150	NIST-traceable calibration
PGT-CC	140	Universal carrying case for all size test gauges



PRESSURE GAUGES G

PGT-45L-100, stem or flush mount, \$390, shown smaller than actual size. See dimensions on page G-61.



PGT-45B-100, back mount, \$390, shown smaller than actual size. See dimensions on page G-61.

Recommended Reference Book:
Pump Handbook,
ME-0341, \$150.
Visit omega.com/bobi
for Additional Books



SPECIAL METRIC RANGES FOR TYPE S (PAGES G-55 TO G-57) AND TYPE T GAUGES (PAGES G-60 TO G-62)

TYPE S RANGE		DIAL GRADUATIONS		RANGE	DIAL GRADUATIONS		OUTER SCALE WHEN DUAL RANGE SPECIFIED (psi)
kg/cm ²	bar	FIGURE INTERVAL	MINOR GRADUATION	kPa	FIGURE INTERVAL	MINOR GRADUATION	
PRESSURE							
0/1	0/1	0.1	0.01	0/100	10	1	0/14
0/1.6	0/1.6	0.2	0.02	0/160	20	2	0/22
0/2.5	0/2.5	0.5	0.05	0/250	50	5	0/35
0/4	0/4	0.5	0.05	0/400	50	5	0/55
0/6	0/6	0.5	0.1	0/600	50	10	0/85
0/10	0/10	1	0.1	0/1000	100	10	0/140
0/16	0/16	2	0.2	0/1600	200	20	0/220
0/25	0/25	5	0.5	0/2500	500	50	0/350
0/40	0/40	5	0.5	0/4000	500	50	0/550
0/60	0/60	5	1	0/6000	500	100	0/850
0/100	0/100	10	1	0/10,000	1000	100	0/1400
0/160	0/160	20	2	0/16,000	2000	200	0/2200
0/250	0/250	50	5	0/25,000	5000	200	0/3500
0/400	0/400	50	5	0/40,000	5000	500	0/5500
0/600	0/600	50	10	0/60,000	5000	500	0/8500
0/1000	0/1000	100	10	0/100,000	10,000	1000	0/14,000
VACUUM							
-1/0	-1/0	0.1	0.01	- 100/0 kPa	10	1	30/0 inHg
COMPOUND							
-1/0/1.5	-1/0/1.5	0.5	0.05	- 100/0/150 kPa	50	5	30 inHg/0/20
-1/0/3	-1/0/3	0.5	0.05	- 100/0/300 kPa	50	5	30 inHg/0/40
-1/0/5	-1/0/5	0.5	0.1	- 100/0/500 kPa	50	10	30 inHg/0/70
-1/0/9	-1/0/9	1	0.1	- 100/0/900 kPa	100	10	30 inHg/0/125
				- 100/0/1500 kPa	200	0	30 inHg/0/215

TYPE T RANGE		
kg/cm ²	bar	kPa
PRESSURE		
0/1	0/1	0/100
0/1.6	0/1.6	0/160
0/2.5	0/2.5	0/250
0/4	0/4	0/400
0/6	0/6	0/600
0/10	0/10	0/1000
0/16	0/16	0/1600
0/25	0/25	0/2500
0/40	0/40	0/4000
0/60	0/60	0/6000
0/100	0/100	0/10,000
0/160	0/160	0/16,000
0/250	0/250	0/25,000
0/400	0/400	0/40,000
0/600	0/600	0/60,000
VACUUM		
-1/0	-1/0	-100/0
COMPOUND		
-1/0/1.5	-1/0/1.5	-100/0/150
-1/0/3	-1/0/3	-100/0/300
-1/0/5	-1/0/5	-100/0/500
-1/0/9	-1/0/9	-100/0/900

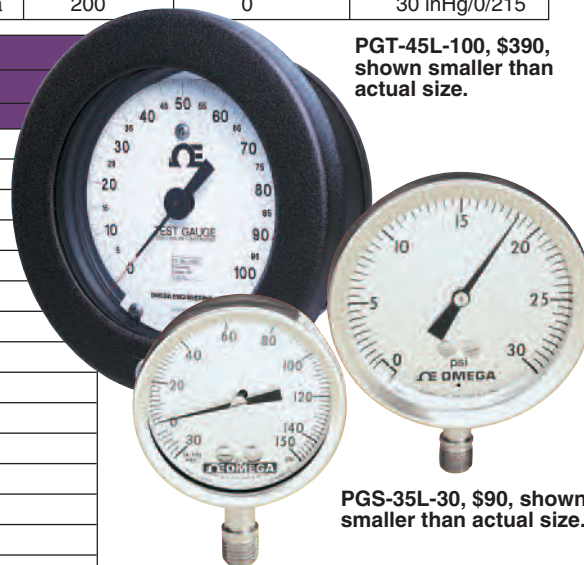

PGT-45L-100, \$390, shown smaller than actual size.

PGS-35L-30, \$90, shown smaller than actual size.

PGS-25L-150, \$80, shown smaller than actual size.

Ordering Special Ranges:
Type S and Type T custom dials are available to fulfill the varying needs of our customers. There is a **\$135 setup fee** and a **5-piece minimum order per customized dial**.



UNITED STATES

www.omega.com
1-800-TC-OMEGA
Stamford, CT.

CANADA

www.omega.ca
Laval(Quebec)
1-800-TC-OMEGA

GERMANY

www.omega.de
Deckenpfronn, Germany
0800-8266342

UNITED KINGDOM

www.omega.co.uk
Manchester, England
0800-488-488

FRANCE

www.omega.fr
Guyancourt, France
088-466-342

CZECH REPUBLIC

www.omegaeng.cz
Karviná, Czech Republic
596-311-899

BENELUX

www.omega.nl
Amstelveen, NL
0800-099-33-44



More than 100,000 Products Available!

• Temperature

Calibrators, Connectors, General Test and Measurement Instruments, Glass Bulb Thermometers, Handheld Instruments for Temperature Measurement, Ice Point References, Indicating Labels, Crayons, Cements and Lacquers, Infrared Temperature Measurement Instruments, Recorders Relative Humidity Measurement Instruments, RTD Probes, Elements and Assemblies, Temperature & Process Meters, Timers and Counters, Temperature and Process Controllers and Power Switching Devices, Thermistor Elements, Probes and Assemblies, Thermocouples Thermowells and Head and Well Assemblies, Transmitters, Wire

• Flow and Level

Air Velocity Indicators, Doppler Flowmeters, Level Measurement, Magnetic Flowmeters, Mass Flowmeters, Pitot Tubes, Pumps, Rotameters, Turbine and Paddle Wheel Flowmeters, Ultrasonic Flowmeters, Valves, Variable Area Flowmeters, Vortex Shedding Flowmeters

• pH and Conductivity

Conductivity Instrumentation, Dissolved Oxygen Instrumentation, Environmental Instrumentation, pH Electrodes and Instruments, Water and Soil Analysis Instrumentation

• Data Acquisition

Auto-Dialers and Alarm Monitoring Systems, Communication Products and Converters, Data Acquisition and Analysis Software, Data Loggers Plug-in Cards, Signal Conditioners, USB, RS232, RS485 and Parallel Port Data Acquisition Systems, Wireless Transmitters and Receivers

• Pressure, Strain and Force

Displacement Transducers, Dynamic Measurement Force Sensors, Instrumentation for Pressure and Strain Measurements, Load Cells, Pressure Gauges, Pressure Reference Section, Pressure Switches, Pressure Transducers, Proximity Transducers, Regulators, Strain Gages, Torque Transducers, Valves

• Heaters

Band Heaters, Cartridge Heaters, Circulation Heaters, Comfort Heaters, Controllers, Meters and Switching Devices, Flexible Heaters, General Test and Measurement Instruments, Heater Hook-up Wire, Heating Cable Systems, Immersion Heaters, Process Air and Duct, Heaters, Radiant Heaters, Strip Heaters, Tubular Heaters