



1/16 DIN Limit Controller

CN6221 Series Starts at

\$205



- ✓ Dual Display
- ✓ Universal Input
- ✓ High or Low Limit
- ✓ Digital Input for Remote Reset
- ✓ RS485 Communications (Optional)
- ✓ Alarms (Optional)
- ✓ Retransmission Output (Optional)

The CN6221 Series is an FM approved limit controller that can be configured either as a high limit or as a low limit controller. The CN6221 features universal input, 2 alarm outputs, retransmission output, a timer to count the total time the setpoint is exceeded, and a register to retain the maximum. The RS485 communication interface is available as an option.

Specifications

Power Supply

Voltage: 100 to 240 Vac ($\pm 10\%$),

Frequency: 50 or 60 Hz

Maximum Power Consumption: 8 Va max (4 W max)

Memory: Non-volatile memory

Withstanding Voltage (Between Primary and Secondary Terminals): 1500 Vac for 1 min (see Note 1)

Insulation Resistance (Between Primary and Secondary Terminals): 20 M Ω or more at 500 Vdc (see Note 1)

Note 1: The primary terminals are the power supply terminals and relay output terminals. The secondary terminals are the analog input and output terminals, the voltage pulse output terminals, and the contact input terminals.

Contact Input

Function: Resetting "exceeded status"

Input: 1 point

Type: Non-voltage contact or transistor contact

Contact Capacity: At least 12V/10 mA

On/Off Judgment: On state for 1 k Ω or less; off state for 20 k Ω or greater

Measured Value (PV)

Input: 1 point

Type: Universal; selectable by software

Accuracy (At 23 $\pm 2^\circ\text{C}$ Ambient Temperature):

Thermocouple: $\pm 2^\circ\text{C} \pm 1$ digit

At -200 to -100 $^\circ\text{C}$: $\pm 4^\circ\text{C}$

At -100 to 0 $^\circ\text{C}$: $\pm 3^\circ\text{C}$

Types R and S: $\pm 5^\circ\text{C}$ [$\pm 9^\circ\text{C}$ for 0 to 500 $^\circ\text{C}$ (32 to 932 $^\circ\text{F}$)]

Type B: $\pm 9^\circ\text{C}$ (accuracy is not guaranteed for 0 to 400 $^\circ\text{C}$)

RTD: $\pm 1^\circ\text{C} \pm 1$ digit

Voltage (mV, V): $\pm 0.3\% \pm 1$ digit

Sampling Period for Measured Value

Input: 500 ms

Burn-Out Detection: Functions for thermocouple or RTD input (burn-out upscale only; cannot be switched off)

Input Resistance: 1 M Ω or greater for thermocouple or DC mV inputs; approx 1 M Ω for DC V input

Maximum Allowable Signal Source

Resistance: 250 Ω for thermocouple or DC mV input; 2 k Ω for DC V input

Maximum Allowable Wiring

Resistance for RTD Input: 10 Ω /wire (resistance values of 3 wires must be the same)

Allowable Input Voltage: ± 10 Vdc for thermocouple or DC mV input; ± 20 Vdc for DC V input

Panel Punches Available Visit omega.com/panelpunches



CN6221-R, \$205, shown smaller than actual size.

Noise Rejection Ratio:

Normal Mode Noise: Minimum 40 dB (50/60 Hz)

Common Mode Noise: Minimum 120 dB (90 dB for DC V input)

Reference Junction Error

Compensation: $\pm 1.5^\circ\text{C}$ (at 15 to 35 $^\circ\text{C}$), $\pm 2.0^\circ\text{C}$ (at 0 to 50 $^\circ\text{C}$)

Note: The reference junction compensation cannot be switched off

Applicable Standards: RTD, Thermocouple, JIS/IEC/DIN (ITS90)

Input Table

Input Type		Range ($^\circ\text{C}$)	Range ($^\circ\text{F}$)
Thermocouple	K	-270 to 1370	-300 to 2500
		0 to 600	32 to 999.9
		0 to 400	32 to 750
	J	-199.9 to 200	-300 to 400
		-199.9 to 999.9	-300 to 2100
		-199.9 to 400	-300 to 750
		-199.9 to 999.9	-300 to 1800
		0 to 1700	32 to 3100
		0 to 1700	32 to 3100
		0 to 1800	32 to 3200
		-200 to 1300	-300 to 2400
		-199.9 to 900	-300 to 1600
-199.9 to 400	-300 to 750		
Platinel 2	0 to 1390	32 to 2500	
RTD	Pt100	-199.9 to 850	-199.9 to 999.9
		0 to 400	32 to 750
		-199.9 to 200	-300 to 400
		-19.9 to 99.9	-199.9 to 999.9
		-199.9 to 500	
DC Voltage	JPt100	0 to 100 mV	0 to 100
		0 to 5V	0 to 5
		1 to 5V	1 to 5
		0 to 10V	0 to 10



Control Output

Output: 1 point

Type: Relay contact

Contact Capacity: 3 A @ 240 Vac or 3 A @ 30 Vdc (with resistance load)

Note: The control output relay cannot be replaced by users.

Alarm Functions (Optional)

Alarm Types: 22 types (waiting action can be set by software): PV high-limit, PV low-limit, deviation high-limit, deviation low-limit, de-energized on deviation highlimit, deenergized on deviation low-limit, deviation high- and low-limits, high- and low-limits within deviation, de-energized on PV high-limit, de-energized on PV low-limit, fault diagnosis output, fail output

Alarm Output: 2 relay contacts

Relay Contact Capacity: 1 A @ 240 Vac or 1 A @ 30 Vdc (with resistance load)

Note: The alarm output relays cannot be replaced by users.

Retransmission Output (Optional)

The retransmission output is provided only when the "/RET" option is specified.

Output Signal: Measured value in 4 to 20 mA_{dc}

Maximum Load Resistance: 600 Ω

Output Accuracy: ±0.3% of span (at 23 ±2°C ambient temperature)

Communication Interface

Applicable Standards: Complies with EIA RS485

Number of Controllers: Up to 31

Maximum Communication Distance: 1200 m (3937')

Communication Method: 2-wire half-duplex, start-stop synchronization, non-procedural

Construction, Mounting, and Wiring Construction: Dust-proof and drip-proof front panel conforming to IP65; for side-by-side close installation, controller loses its dust-proof and drip-proof protection

Casing: ABS resin and polycarbonate

Case Color: Black

Mounting: Flush panel mounting

Environmental Conditions

Normal Operating Conditions

Warm-Up Time: At least 30 minutes

Ambient Temperature: 0 to 50°C (0 to 40°C when mounted side-by-side)

Rate of Change of Temperature: 10°C/h or less

Ambient Humidity: 20 to 90% RH (no condensation allowed)

Magnetic Field: 400 A/m or less

Continuous Vibrations of 5 to 14 Hz: Amplitude of 1.2 mm or less

Continuous Vibrations of 14 to 150 Hz: 4.9 m/s² (0.5 G) or less

Short-Period Vibrations: 14.7 m/s² (1.5 G) for 15 seconds or less

Shock: 98 m/s² (10 G) for 11 ms or less

Mounting Angle: Upward incline of up to 30 degrees; no downward incline

Altitude: ≤2000 m above sea level

Maximum Effects from Operating Conditions

Temperature Effects

Thermocouple, mVdc and Vdc

Inputs: ±2 μV/°C or ±0.02% of FS/°C, whichever is the larger

Resistance Temperature

Detector: ±0.05°C/°C

Analog Output: ±0.05% of FS/°C

Effect from Fluctuation of Power Supply Voltage (Within Rated Voltage Range)

Analog Input: ±0.2 μV/V or ±0.002% of FS/V, whichever is larger

Analog Output: ±0.05% of FS/V

Transportation and Storage Conditions

Temperature: -25 to 70°C (-13 to 158°F)

Humidity: 5 to 95% RH

(no condensation allowed)

Shock: Package drop height 90 cm (35") (when packed in the dedicated package)

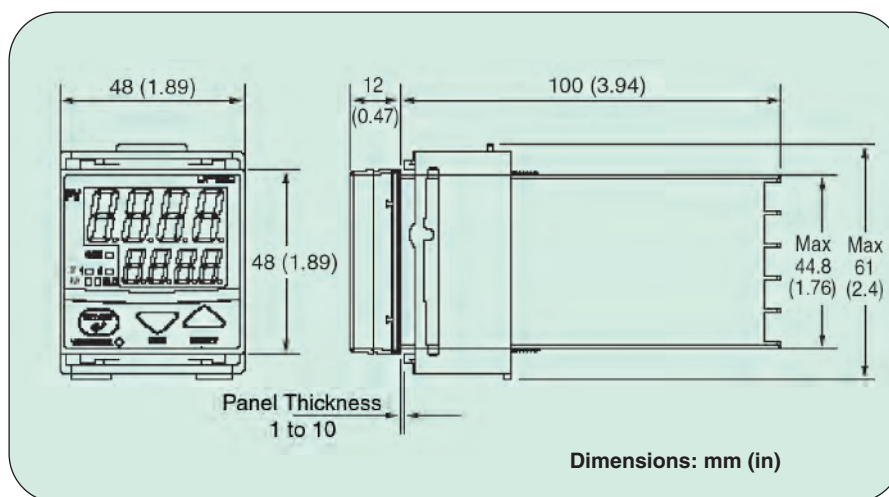

AVAILABLE FOR FAST DELIVERY!

To Order (Specify Model Number)

Model No.	Price	Description
CN6221-R	\$205	Limit controller, single relay output

Options

Ordering Suffix	Add'l Price	Description
-AL	\$20	Dual alarms
-PV	40	4 to 20 mA retransmission output
-C4*	95	RS485 communications
-DI *	20	Digital input switching

* Only one option can be ordered.

Accessories (Field Installable)

Model No.	Price	Description
CNQUENCHARC	\$8	Noise suppression kit, 110 to 230 Vac
DPP-4	475	1/16 DIN panel punch

Comes complete with operator's manual.

Ordering Example: CN6221-R-C4, single output limit controller, mechanical relay, RS485 communications, \$205 + 95 = \$300.

Recommended Reference Book: Grounding and Shielding Techniques, EE-1319, \$95, See Section Y For Additional Books



UNITED STATES

www.omega.com
1-800-TC-OMEGA
Stamford, CT.

CANADA

www.omega.ca
Laval(Quebec)
1-800-TC-OMEGA

GERMANY

www.omega.de
Deckenpfronn, Germany
0800-8266342

UNITED KINGDOM

www.omega.co.uk
Manchester, England
0800-488-488

FRANCE

www.omega.fr
Guyancourt, France
088-466-342

CZECH REPUBLIC

www.omegaeng.cz
Karviná, Czech Republic
596-311-899

BENELUX

www.omega.nl
Amstelveen, NL
0800-099-33-44



More than 100,000 Products Available!

• Temperature

Calibrators, Connectors, General Test and Measurement Instruments, Glass Bulb Thermometers, Handheld Instruments for Temperature Measurement, Ice Point References, Indicating Labels, Crayons, Cements and Lacquers, Infrared Temperature Measurement Instruments, Recorders Relative Humidity Measurement Instruments, RTD Probes, Elements and Assemblies, Temperature & Process Meters, Timers and Counters, Temperature and Process Controllers and Power Switching Devices, Thermistor Elements, Probes and Assemblies, Thermocouples Thermowells and Head and Well Assemblies, Transmitters, Wire

• Flow and Level

Air Velocity Indicators, Doppler Flowmeters, Level Measurement, Magnetic Flowmeters, Mass Flowmeters, Pitot Tubes, Pumps, Rotameters, Turbine and Paddle Wheel Flowmeters, Ultrasonic Flowmeters, Valves, Variable Area Flowmeters, Vortex Shedding Flowmeters

• pH and Conductivity

Conductivity Instrumentation, Dissolved Oxygen Instrumentation, Environmental Instrumentation, pH Electrodes and Instruments, Water and Soil Analysis Instrumentation

• Data Acquisition

Auto-Dialers and Alarm Monitoring Systems, Communication Products and Converters, Data Acquisition and Analysis Software, Data Loggers Plug-in Cards, Signal Conditioners, USB, RS232, RS485 and Parallel Port Data Acquisition Systems, Wireless Transmitters and Receivers

• Pressure, Strain and Force

Displacement Transducers, Dynamic Measurement Force Sensors, Instrumentation for Pressure and Strain Measurements, Load Cells, Pressure Gauges, Pressure Reference Section, Pressure Switches, Pressure Transducers, Proximity Transducers, Regulators, Strain Gages, Torque Transducers, Valves

• Heaters

Band Heaters, Cartridge Heaters, Circulation Heaters, Comfort Heaters, Controllers, Meters and Switching Devices, Flexible Heaters, General Test and Measurement Instruments, Heater Hook-up Wire, Heating Cable Systems, Immersion Heaters, Process Air and Duct, Heaters, Radiant Heaters, Strip Heaters, Tubular Heaters