

Intrinsic Safety

Introduction

Intrinsically safe equipment is defined as "equipment and wiring which is incapable of releasing sufficient electrical or thermal energy under normal or abnormal conditions to cause ignition of a specific hazardous atmospheric mixture in its most easily ignited concentration." (ISA-RP12.6) This is achieved by limiting the amount of power available to the electrical equipment in the hazardous area to a level below that which will ignite the gases.

In order to have a fire or explosion, fuel, oxygen and a source of ignition must be present. An intrinsically safe system assumes the fuel and oxygen is present in the atmosphere, but the system is designed so the electrical energy or thermal energy of a particular instrument loop can never be great enough to cause ignition.

Traditionally, protection from explosion in hazardous environments has been accomplished by either using EXPLOSION PROOF apparatus which can contain

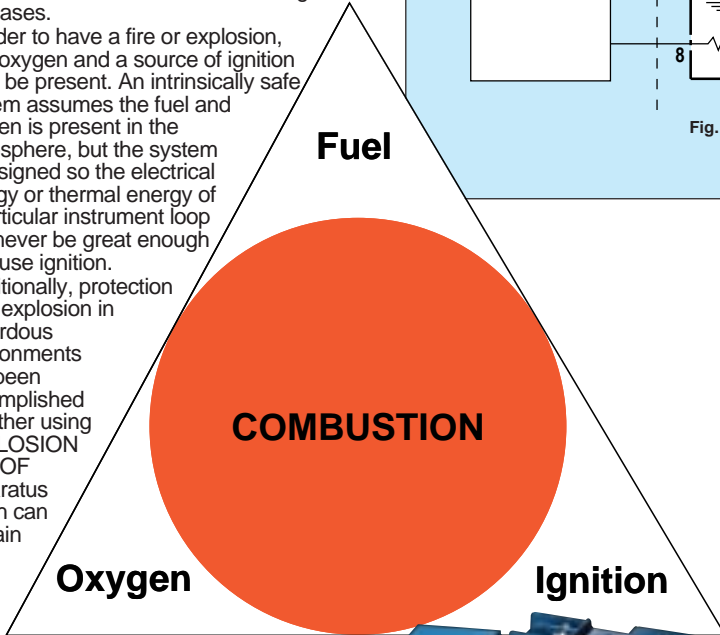

an explosion inside an enclosure, or PRESSURIZATION or purging which isolates the explosive gas from the electrical equipment. Intrinsically safe apparatus cannot replace these methods in all applications, but where possible can provide significant cost savings in installation and maintenance of the equipment in a Hazardous area. The basic design of an intrinsic safety barrier uses Zener Diodes to limit voltage, resistors to limit current and a fuse.

Applications

A Hazardous Area may contain flammable gasses or vapors, combustible dusts, or ignitable fibers or flyings. There are different systems used in Europe or the United States to classify the type of hazard and whether the Hazard is always present or only present in an emergency condition such as a spill or failure of venting equipment. Refer to Section Z, Technical Reference, for additional information. In most cases the equipment is designed for the worst case, which would be to assume the explosive atmosphere is always present and the electrical or thermal energy is the lowest required to cause a fire or explosion.



OMEGA offers the SBG Series Single & Dual Channel Zener Barriers and Solid State Relays for Intrinsic Safety. See Section K of the OMEGA Complete Flow and Level Measurement Handbook and Encyclopedia®

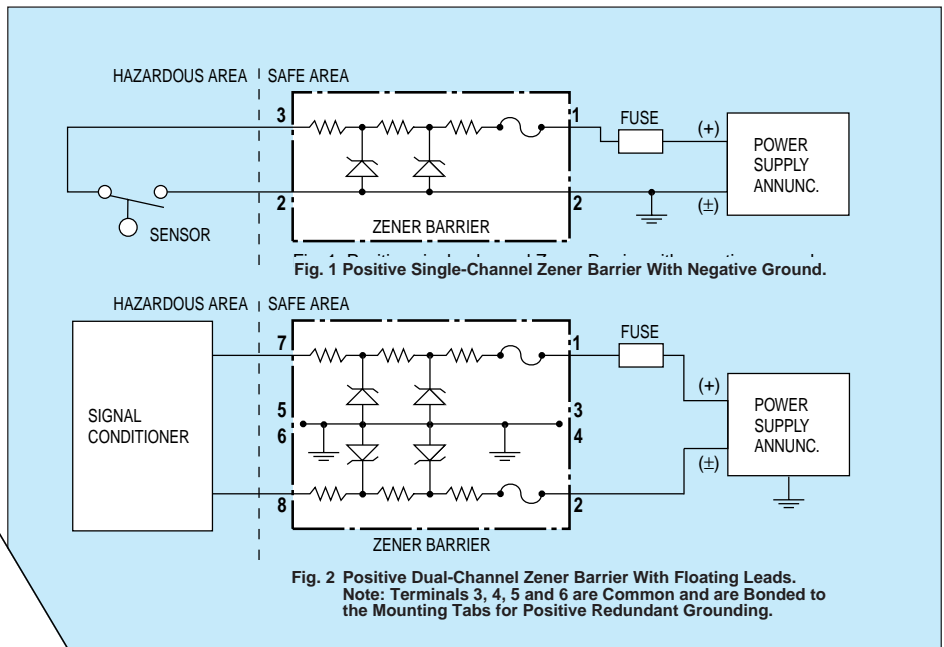

Fig. 1 Positive Single-Channel Zener Barrier With Negative Ground.

Fig. 2 Positive Dual-Channel Zener Barrier With Floating Leads. Note: Terminals 3, 4, 5 and 6 are Common and are Bonded to the Mounting Tabs for Positive Redundant Grounding.

Most applications require a signal to be sent out of or into the hazardous area. The equipment mounted in the hazardous area must first be approved for use in an intrinsically safe system. The barriers designed to protect the system must be mounted outside of the hazardous area in an area designated as Non-hazardous or Safe in which the hazard is not and will not be present.

Equipment which has been designed for and is available for use in hazardous areas with intrinsically safe barriers includes:

- 4 to 20 mAdc Two Wire Transmitters
- Thermocouples
- RTD's
- Strain Gages
- Pressure, Flow, & Level Switches
- I/P Converters
- Solenoid Valves
- Proximity Switches
- Infrared Temperature Sensors
- Potentiometers
- LED Indicating Lights
- Magnetic Pickup Flowmeters

Most of the apparatus that is mounted in the Hazardous area will have to be approved and certified for use in the Hazardous area with that apparatus. Some simple devices like thermocouples, RTD's, LED's and contacts can be used in the hazardous area without certification as long as it is wired in conjunction with an approved barrier.

Approvals

Intrinsic safety equipment must have been tested and approved by an independent agency to assure its safety. The customer should specify the type of

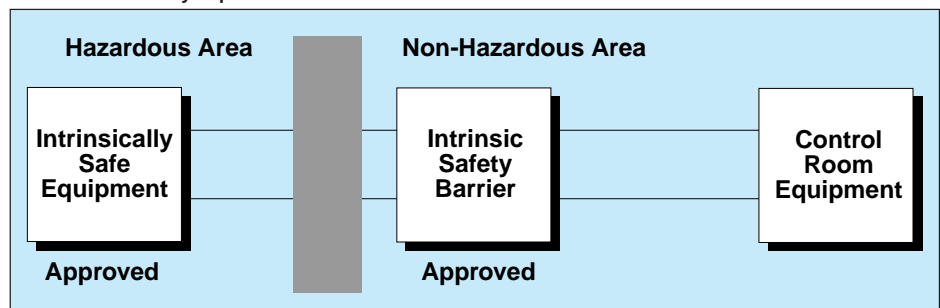



UNITED STATES

www.omega.com
1-800-TC-OMEGA
Stamford, CT.

CANADA

www.omega.ca
Laval(Quebec)
1-800-TC-OMEGA

GERMANY

www.omega.de
Deckenpfronn, Germany
0800-8266342

UNITED KINGDOM

www.omega.co.uk
Manchester, England
0800-488-488

FRANCE

www.omega.fr
Guyancourt, France
088-466-342

CZECH REPUBLIC

www.omegaeng.cz
Karviná, Czech Republic
596-311-899

BENELUX

www.omega.nl
Amstelveen, NL
0800-099-33-44



More than 100,000 Products Available!

• Temperature

Calibrators, Connectors, General Test and Measurement Instruments, Glass Bulb Thermometers, Handheld Instruments for Temperature Measurement, Ice Point References, Indicating Labels, Crayons, Cements and Lacquers, Infrared Temperature Measurement Instruments, Recorders Relative Humidity Measurement Instruments, RTD Probes, Elements and Assemblies, Temperature & Process Meters, Timers and Counters, Temperature and Process Controllers and Power Switching Devices, Thermistor Elements, Probes and Assemblies, Thermocouples Thermowells and Head and Well Assemblies, Transmitters, Wire

• Flow and Level

Air Velocity Indicators, Doppler Flowmeters, Level Measurement, Magnetic Flowmeters, Mass Flowmeters, Pitot Tubes, Pumps, Rotameters, Turbine and Paddle Wheel Flowmeters, Ultrasonic Flowmeters, Valves, Variable Area Flowmeters, Vortex Shedding Flowmeters

• pH and Conductivity

Conductivity Instrumentation, Dissolved Oxygen Instrumentation, Environmental Instrumentation, pH Electrodes and Instruments, Water and Soil Analysis Instrumentation

• Data Acquisition

Auto-Dialers and Alarm Monitoring Systems, Communication Products and Converters, Data Acquisition and Analysis Software, Data Loggers Plug-in Cards, Signal Conditioners, USB, RS232, RS485 and Parallel Port Data Acquisition Systems, Wireless Transmitters and Receivers

• Pressure, Strain and Force

Displacement Transducers, Dynamic Measurement Force Sensors, Instrumentation for Pressure and Strain Measurements, Load Cells, Pressure Gauges, Pressure Reference Section, Pressure Switches, Pressure Transducers, Proximity Transducers, Regulators, Strain Gages, Torque Transducers, Valves

• Heaters

Band Heaters, Cartridge Heaters, Circulation Heaters, Comfort Heaters, Controllers, Meters and Switching Devices, Flexible Heaters, General Test and Measurement Instruments, Heater Hook-up Wire, Heating Cable Systems, Immersion Heaters, Process Air and Duct, Heaters, Radiant Heaters, Strip Heaters, Tubular Heaters