

Infrared Thermocouples

OS36 Series
Starts at
\$255



For a complete selection of meters and controllers for use with OMEGA's infrared thermocouples, see section M

OS36
\$255

Dimensions: mm (in)

OS36-2
\$355

OS36-5
\$475

OS36-10
\$499

- ✓ No Thermal Mass Errors
- ✓ No Moving Parts
- ✓ Self-Powered with No Internal or External Power Requirements
- ✓ No Frictional Heat Errors for Moving Surfaces
- ✓ Temperature Compensated
- ✓ Use with Standard Thermocouple Indicators and Controllers

The unique OS36 infrared thermocouple combines low cost with the advantages of non-contact temperature measurement. It produces an output signal compatible with any standard J, K, T, or E thermocouple instrumentation. The thermocouple's accuracy is specified for target emissivity between 0.8 and 1.0. For other emissivity values, readings can be corrected to provide accurate measurements. Even without correction, the readings are extremely repeatable, for use in process and quality-control applications.

Specifications

Accuracy: ±2% of nominal range; blackbody source

Repeatability: ±1% rdg

Temperature Coefficient: ±0.02% nominal range per °F

Temperature Compensation Range: Complies with ASTM standards over 27 to 93°C (80 to 200°F) range

Operating Ambient Temperature Range: -18 to 85°C (0 to 185°F) with internal cold junction compensation

Ambient Temperature Compensation: Internal temperature cold junction compensation up to 538°C (1000°F) water-cooled, 400°C (750°F) air-cooled, with cooling jacket option model OS36-APC

Storage Temperature Range: -45 to 121°C (-50 to 250°F)

Output Impedance: 3 kΩ

Response Time: 80 ms

Spectral Response: 6.5 to 14 microns

Field of View: 60°; specified accuracy for target distances up to 12.7 mm (0.5")

Dimensions: 44.5 L x 12.7 mm Dia. (1.75 x 0.5"); 2.4 m (8') PFA coated lead wires

Housing: Stainless steel with silicon window, hermetically encapsulated

Weight: 15 g (0.5 oz) head only



The DP41 thermocouple indicator is a high-accuracy meter, with 0.01° resolution; computer interface and analog/digital outputs are available. See section M for details.

Range Chart

Range Code	Temperature Range (2% Accuracy)
50F	-18 to 27°C (0 to 80°F)
80F	10 to 49°C (50 to 120°F)
98.6F	16 to 39°C (60 to 102°F)
140F	25 to 80°C (80 to 180°F)
180F	70 to 104°C (160 to 220°F)
240F	95 to 130°C (200 to 270°F)
280F	125 to 155°C (260 to 310°F)
340F	145 to 175°C (290 to 350°F)
440F	170 to 250°C (340 to 480°F)

MOST POPULAR MODEL HIGHLIGHTED!

To Order (Specify Model Number)

Model No.†	Price	Description
OS36-J-*	\$255	J thermocouple
OS36-K-*	255	K thermocouple
OS36-T-*	255	T thermocouple
OS36-E-*	255	E thermocouple
OS36-#-KIT (Save \$153!)	1377	6-unit kit, includes 1 of each temperature range
OS36-MB	25	Mounting bracket
OS36-MR	40	Mounting ring
OS36-APC	439	Cooling jacket

* Specify temperature range code from range chart above.

(#) Specify calibration, J, K, E, T. **Note:** Kit includes 1 unit each of the most popular ranges (6 total) of 1 thermocouple calibration.

Note: Standard unit configuration is stripped leads. To order with GMP subminiature low-noise thermocouple connector pair, add suffix “-GMP” to model number and \$12 to price. To order with GST standard size low-noise thermocouple connector pair, add suffix “-GST” to model number and \$12 to price.

Ordering Examples: OS36-K-180F, infrared thermocouple sensor, Type K, with 160 to 220°F range, \$255.

OS36-J-140F-GMP, infrared thermocouple sensor, Type J, with 80 to 180°F range, GMP low-noise subminiature connectors, \$255 + 12 = \$267.

†Right-Angle Models

To order with right-angle view, for use in difficult-to-view applications, change model number from “OS36” to “OS36-RA” and add \$24 to price.

†8-angle models come with 0.9 m (3') leads

Ordering Example: OS36-RA-K-240F, infrared thermocouple, Type K, 95 to 130°C range, right-angle view, stripped lead termination, \$255 + 24 = \$279.



OS36 Series with Stainless Steel housing, \$255 each, shown actual size.

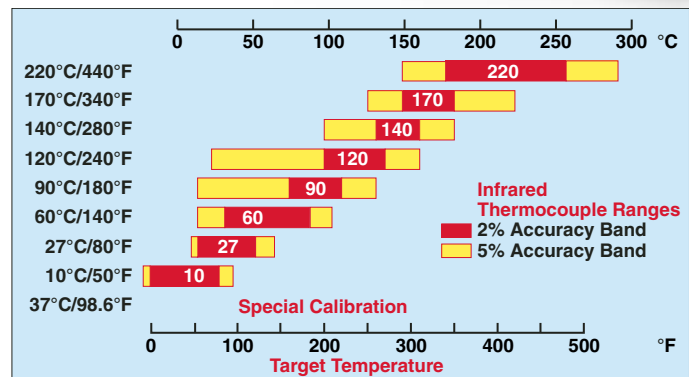

Termination Styles

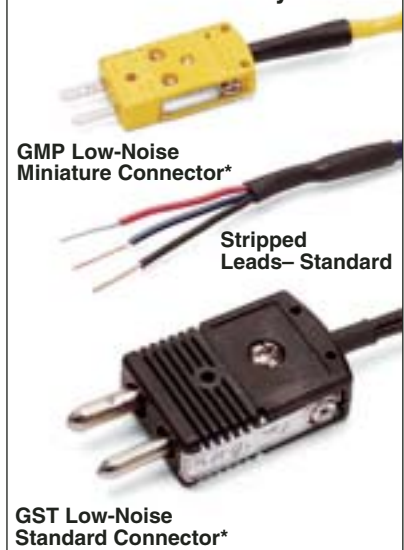

* Both the GMP and GST termination styles include the mating connector.



UNITED STATES

www.omega.com
1-800-TC-OMEGA
Stamford, CT.

CANADA

www.omega.ca
Laval(Quebec)
1-800-TC-OMEGA

GERMANY

www.omega.de
Deckenpfronn, Germany
0800-8266342

UNITED KINGDOM

www.omega.co.uk
Manchester, England
0800-488-488

FRANCE

www.omega.fr
Guyancourt, France
088-466-342

CZECH REPUBLIC

www.omegaeng.cz
Karviná, Czech Republic
596-311-899

BENELUX

www.omega.nl
Amstelveen, NL
0800-099-33-44



More than 100,000 Products Available!

• Temperature

Calibrators, Connectors, General Test and Measurement Instruments, Glass Bulb Thermometers, Handheld Instruments for Temperature Measurement, Ice Point References, Indicating Labels, Crayons, Cements and Lacquers, Infrared Temperature Measurement Instruments, Recorders Relative Humidity Measurement Instruments, RTD Probes, Elements and Assemblies, Temperature & Process Meters, Timers and Counters, Temperature and Process Controllers and Power Switching Devices, Thermistor Elements, Probes and Assemblies, Thermocouples Thermowells and Head and Well Assemblies, Transmitters, Wire

• Flow and Level

Air Velocity Indicators, Doppler Flowmeters, Level Measurement, Magnetic Flowmeters, Mass Flowmeters, Pitot Tubes, Pumps, Rotameters, Turbine and Paddle Wheel Flowmeters, Ultrasonic Flowmeters, Valves, Variable Area Flowmeters, Vortex Shedding Flowmeters

• pH and Conductivity

Conductivity Instrumentation, Dissolved Oxygen Instrumentation, Environmental Instrumentation, pH Electrodes and Instruments, Water and Soil Analysis Instrumentation

• Data Acquisition

Auto-Dialers and Alarm Monitoring Systems, Communication Products and Converters, Data Acquisition and Analysis Software, Data Loggers Plug-in Cards, Signal Conditioners, USB, RS232, RS485 and Parallel Port Data Acquisition Systems, Wireless Transmitters and Receivers

• Pressure, Strain and Force

Displacement Transducers, Dynamic Measurement Force Sensors, Instrumentation for Pressure and Strain Measurements, Load Cells, Pressure Gauges, Pressure Reference Section, Pressure Switches, Pressure Transducers, Proximity Transducers, Regulators, Strain Gages, Torque Transducers, Valves

• Heaters

Band Heaters, Cartridge Heaters, Circulation Heaters, Comfort Heaters, Controllers, Meters and Switching Devices, Flexible Heaters, General Test and Measurement Instruments, Heater Hook-up Wire, Heating Cable Systems, Immersion Heaters, Process Air and Duct, Heaters, Radiant Heaters, Strip Heaters, Tubular Heaters