

**FLOW CHART**

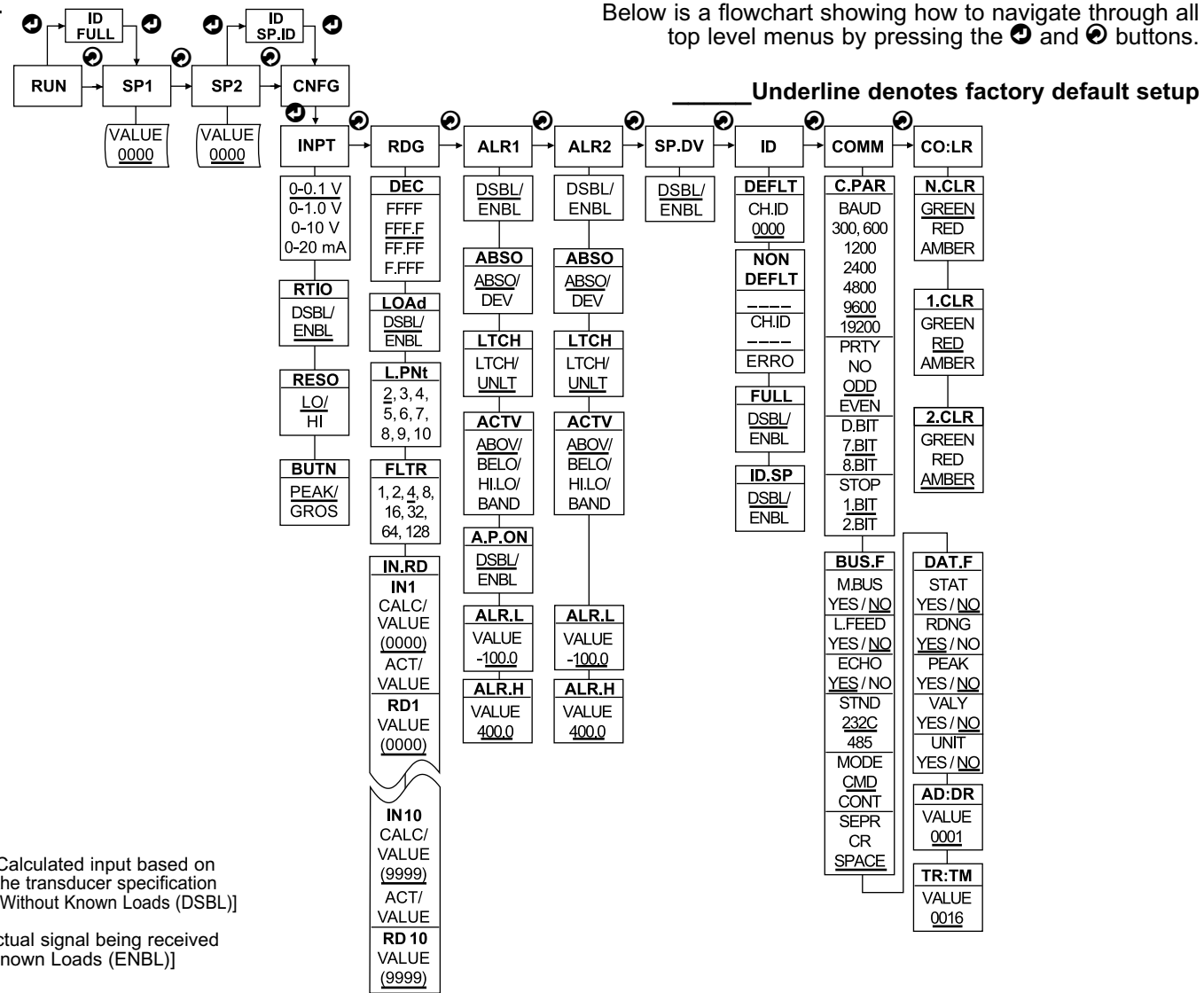

Below is a flowchart showing how to navigate through all top level menus by pressing the **↶** and **↷** buttons.

Underline denotes factory default setup

<sup>†</sup>Where:  
CALC/VALUE = Calculated input based on the transducer specification [Without Known Loads (DSBL)]

ACT/VALUE = Actual signal being received [Known Loads (ENBL)]

**READING CONFIGURATION SETUP (operation example)**

Below is a flowchart showing how to navigate through the submenus of the Reading Configuration menu item by pressing the front buttons.

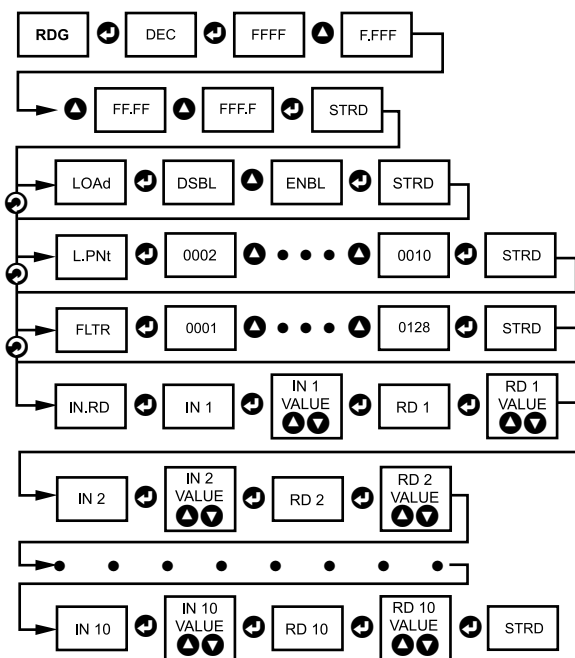

**DISPLAY COLOR SETUP (examples)**

**Example 1:**  
Output 1 & Output 2: SSR  
Alarm setup: Absolute, Above, Alarm 2 HI Value "ALR.H" =200, Alarm 1 HI Value "ALR.H"=400  
Color Display setup: Normal Color "N.CLR"=Green, Alarm 1 Color "1.CLR"=Amber, Alarm 2 Color "2.CLR"=Red

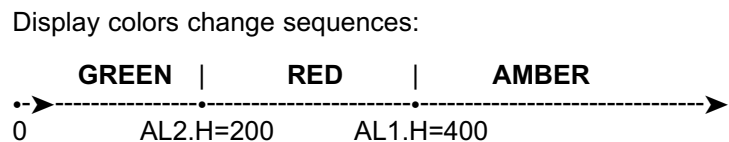

**Example 2:**  
Output 1: Relay, Set Point 1 = 200,  
Output 2: Relay, Set Point 2 = 200  
Alarm 1 setup: Deviation, Band, "ALR.H" = 20  
Alarm 2 setup: Deviation, Hi/Low, "ALR.H = 10", "ALR.L = 5"  
Color Display setup: "N.CLR"=Green, "1.CLR"=Amber, "2.CLR"=Red

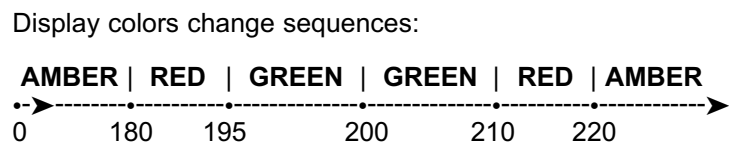

**SPECIFICATION**

- Accuracy:** 0.03% rdg.
  - Resolution:** 10 / 1 µV process
  - Linearization Points:** 10 points
  - Temperature Stability:** 50 ppm/°C process
  - Display:** 4-digit, 7-segment LED, 57.2 mm (2.25") with red, green and amber programmable colors.
  - Input Types:** Analog Voltage and Current
  - Voltage:** 0 to 100 mV, 0 to 1 V (±100 mV), 0 to 10 Vdc
  - Input Impedance:** 10 MΩ for 100 mV, 1 MΩ for 1 or 10 Vdc
  - Current:** 0 to 20 mA (5 Ω load)
- Options: Communication**  
RS-232 / RS-485 or  
**Excitation** 5Vdc @40mA, 10Vdc @60mA
- Power Supply:**  
100-240 Vac ±10%, 50/60 Hz, 22.5 W
- Operating Temperature:** 0 to 40°C  
**Storage Temperature:** -20 to 60°C  
**Relative Humidity:** 0 to 85%
- Protection:**  
NEMA-4x (IP65)
- Dimensions:**  
289 L x 137 W x 73 D mm  
(11.75" L x 5.375" W x 2.875" D)
- Panel Cutout:**  
279.4 L x 116.8 W mm  
(11.00" L x 4.60" W)
- Weight:**  
1,360 g (3 lbs)
- Approvals:**  
CE per EN50081-1, EN50082-2, EN61010-1

**WARNING:** These products are not designed for use in, and should not be used for, patient-connected applications.

This device is marked with the international caution symbol. It is important to read the Setup Guide before installing or commissioning this device, as the guide contains important information relating to safety and EMC.

It is the policy of OMEGA to comply with all worldwide safety and EMC/EMI regulations that apply. OMEGA is constantly pursuing certification of its products to the European New Approach Directives. OMEGA will add the CE mark to every appropriate device upon certification.

The information contained in this document is believed to be correct, but OMEGA Engineering, Inc. accepts no liability for any errors it contains, and reserves the right to alter specifications without notice.

**TRADEMARK NOTICE:**

Ω, omega.com, OMEGA, and Ω are Trademarks of OMEGA ENGINEERING, INC.

**WARRANTY/DISCLAIMER**

OMEGA ENGINEERING, INC. warrants this unit to be free of defects in materials and workmanship for a period of one (1) year from the date of purchase. In addition to OMEGA's standard warranty period, OMEGA Engineering will extend the warranty period for four (4) additional years if the warranty card enclosed with each instrument is returned to OMEGA.

If the unit malfunctions, it must be returned to the factory for evaluation. OMEGA's Customer Service Department will issue an Authorized Return (AR) number immediately upon phone or written request. Upon examination by OMEGA, if the unit is found to be defective, it will be repaired or replaced at no charge. OMEGA's WARRANTY does not apply to defects resulting from any action of the purchaser, including but not limited to mishandling, improper interfacing, operation outside of design limits, improper repair, or unauthorized modification. This WARRANTY is VOID if the unit shows evidence of having been tampered with or shows evidence of having been damaged as a result of excessive corrosion, or current, heat, moisture or vibration; improper specification, misapplication, misuse or other operating conditions outside of OMEGA's control. Components which wear are not warranted, including but not limited to contact points, fuses, and triacs.

OMEGA is pleased to offer suggestions on the use of its various products. However, OMEGA neither assumes responsibility for any omissions or errors nor assumes liability for any damages that result from the use of its products in accordance with information provided by OMEGA, either verbal or written. OMEGA warrants only that the parts manufactured by it will be as specified and free of defects. OMEGA MAKES NO OTHER WARRANTIES OR REPRESENTATIONS OF ANY KIND WHATSOEVER, EXPRESS OR IMPLIED, EXCEPT THAT OF TITLE, AND ALL IMPLIED WARRANTIES INCLUDING ANY WARRANTY OF MERCHANTABILITY AND FITNESS FOR A PARTICULAR PURPOSE ARE HEREBY DISCLAIMED. LIMITATION OF LIABILITY: The remedies of purchaser set forth herein are exclusive, and the total liability of OMEGA with respect to this order, whether based on contract, warranty, negligence, indemnification, strict liability or otherwise, shall not exceed the purchase price of the component upon which liability is based. In no event shall OMEGA be liable for consequential, incidental or special damages.

CONDITIONS: Equipment sold by OMEGA is not intended to be used, nor shall it be used: (1) as a "Basic Component" under 10 CFR 21 (NRC), used in or with any nuclear installation or activity; or (2) in medical applications or used on humans. Should any Product(s) be used in or with any nuclear installation or activity, medical application, used on humans, or misused in any way, OMEGA assumes no responsibility as set forth in our basic WARRANTY/DISCLAIMER language, and, additionally, purchaser will indemnify OMEGA and hold OMEGA harmless from any liability or damage whatsoever arising out of the use of the Product(s) in such a manner.

**RETURN REQUESTS/INQUIRIES**

Direct all warranty and repair requests/inquiries to the OMEGA Customer Service Department, BEFORE RETURNING ANY PRODUCT(S) TO OMEGA. PURCHASER MUST OBTAIN AN AUTHORIZED RETURN (AR) NUMBER FROM OMEGA'S CUSTOMER SERVICE DEPARTMENT (IN ORDER TO AVOID PROCESSING DELAYS). The assigned AR number should then be marked on the outside of the return package and on any correspondence.

The purchaser is responsible for shipping charges, freight, insurance and proper packaging to prevent breakage in transit.

FOR WARRANTY RETURNS, please have the following information available BEFORE contacting OMEGA:

- Purchase Order number under which the product was PURCHASED.
- Model and serial number of the product under warranty.
- Repair instructions and/or specific problems relative to the product.

FOR NON-WARRANTY REPAIRS, consult OMEGA for current repair charges. Have the following information available BEFORE contacting OMEGA:

- Purchase Order number to cover the COST of the repair.
- Model and serial number of product, and
- Repair instructions and/or specific problems relative to the product.

OMEGA's policy is to make running changes, not model changes, whenever an improvement is possible. This affords our customers the latest in technology and engineering.

OMEGA is a registered trademark of OMEGA ENGINEERING, INC.

© Copyright 2003 OMEGA ENGINEERING, INC. All rights reserved. This document may not be copied, photocopied, reproduced, translated, or reduced to any electronic medium or machine-readable form, in whole or in part, without the prior written consent of OMEGA ENGINEERING, INC.

PATENT AND TRADEMARK NOTICE: This product is covered by one or more of the following patents: U.S. Pat. No. Des. 336,895; 5,274,577; 6,243,021/ CANADA 2052599; 2052600/ ITALY 1249456; 1250938/ GERMANY DE 41 34398 C2/ SPAIN 2039150; 2048066/ UK Patent No. GB 2 249 837; GB 2 248 954/ FRANCE BREVET NO. 91 12756. Other U.S. and International Patents pending or applied for.



**iSeries** iLD24 Big Display Universal Strain & Process Monitor



<b>OMEGAnet® On-Line Service</b> www.omega.com	<b>Internet e-mail</b> info@omega.com
---	--

**Servicing North America:**

<b>USA:</b> ISO 9001 Certified	One Omega Drive, P.O. Box 4047 Stamford CT 06907-0047 TEL: (203) 359-1660 e-mail: info@omega.com	FAX: (203) 359-7700
<b>Canada:</b>	976 Bergar Laval (Quebec) H7L 5A1 TEL: (514) 856-6928 e-mail: info@omega.ca	FAX: (514) 856-6886

**For immediate technical or application assistance:**

**USA and Canada:** Sales Service: 1-800-826-6342 / 1-800-TC-OMEGA®  
Customer Service: 1-800-622-2378 / 1-800-622-BEST®  
Engineering Service: 1-800-872-9436 / 1-800-USA-WHEN®

**Mexico and Latin American:** TEL: (001)800-TC-OMEGA® FAX: (001) 203-359-7807  
En Español: (001) 203-359-7803  
e-mail: espanol@omega.com

**Servicing Europe:**

<b>Benelux:</b>	Postbus 8034, 1180 LA Amstelveen, The Netherlands TEL: +31 20 3472121 Toll Free in Benelux: 0800 0993344 e-mail: sales@omegaeng.nl	FAX: +31 20 6434643
<b>Czech Republic:</b>	Frystatska 184, 733 01 Karviná TEL: +420 59 6311899 e-mail: info@omegashop.cz	FAX: +420 59 6311114
<b>France:</b>	11, rue Jacques Cartier, 78280 Guyancourt TEL: +33 1 61 37 29 00 Toll Free in France: 0800 466 342 e-mail: sales@omega.fr	FAX: +33 1 30 57 54 27
<b>Germany/Austria:</b>	Daimlerstrasse 26, D-75392 Deckenpfronn, Germany TEL: +49 7056 9398-0 Toll Free in Germany: 0800 639 7678 e-mail: info@omega.de	FAX: +49 7056 9398-29
<b>United Kingdom:</b> ISO 9002 Certified	One Omega Drive River Bend Technology Centre Northbank, Irlam Manchester M44 5BD United Kingdom TEL: +44 161 777 6611 Toll Free in England: 0800 488 488 e-mail: sales@omega.co.uk	FAX: +44 161 777 6622



This Quick Start Reference provides information on setting up your instrument for basic operation. The latest complete Communication and Operational Manual as well as free Software and ActiveX Controls are available at [www.omega.com](http://www.omega.com) or on the CD-ROM enclosed with your shipment.

### SAFETY CONSIDERATION



**This device is marked with the international Caution symbol.**

The instrument is a panel mount device protected in accordance with Class II of EN61010-1. Remember that the unit has no power-on switch. Building installation should include a switch or circuit-breaker that must be compliant to IEC 947-1 and 947-3.

### SAFETY:

- Do not exceed voltage rating on the label located on the back of the instrument housing.
- Always disconnect power before changing signal and power connections.
- Do not use this instrument on a work bench without its case for safety reasons.
- Do not operate this instrument in flammable or explosive atmospheres.

### EMC:

- Whenever EMC is an issue, always use shielded cables.
- Never run signal and power wires in the same conduit.
- Use signal wire connections with twisted-pair cables.
- Install Ferrite Bead(s) on signal wire close to the instrument if EMC problems persist.

### MOUNTING

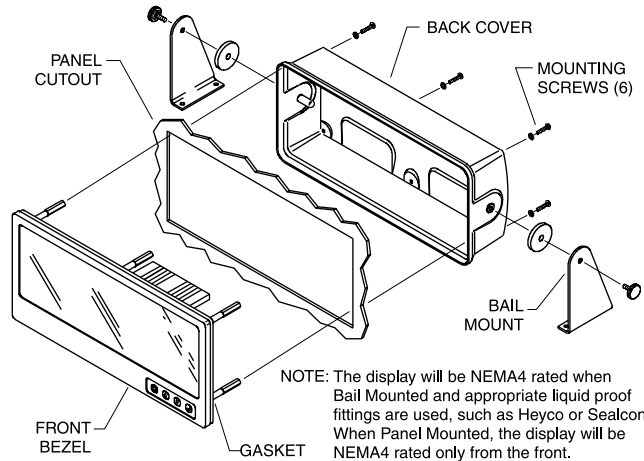
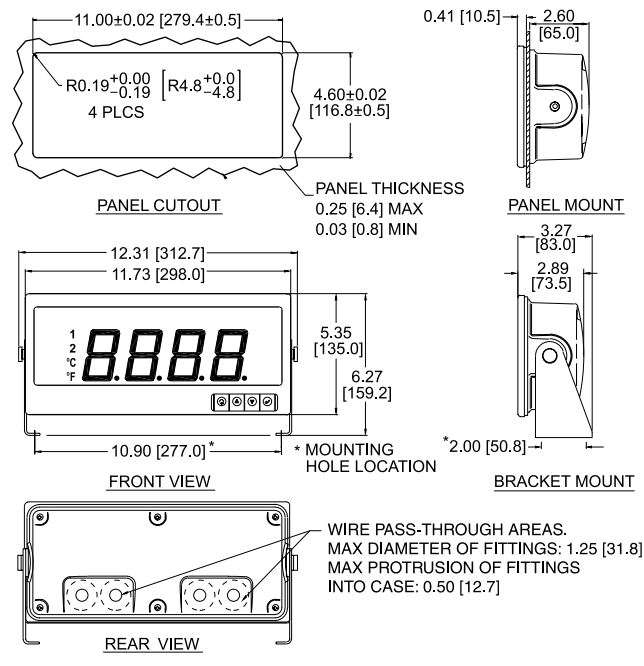

### Mounting Big Display Through Panel:

- Using the panel cutout diagram shown above, cut an opening in the panel.
- Remove six screws at the back of Big Display to remove back cover.
- Insert the unit into the opening from the front of the panel, so the gasket seals between the bezel and the front of the panel.
- Align back cover to Big Display and reinstall screws.

### Mounting Big Display on Bail:

- Mark the location of mounting screws on the flat surface.
- Be sure to leave enough room around the bail to allow for removal and rotation of the display.
- The display can be rotated for the best viewing angle.

### Disassembly Instruction:



**Warning: Disconnect all ac power from the unit before proceeding.**

- Remove all wiring connections from the rear of the instrument, by unscrewing the power and input connectors.
- Remove six screws at the back of the display and back cover.
- Remove the Big Display from the panel.
- To remove the Big Display from the bail, unscrew the two knobs at each end of the mounting brackets.

### WIRING

Wire the instrument according to the figure shown below.



**Warning: Do not connect ac power to your device until you have completed all input and output connections. This device must only be installed by a specially trained electrician with corresponding qualifications. Failure to follow all instructions and warnings may result in injury!**

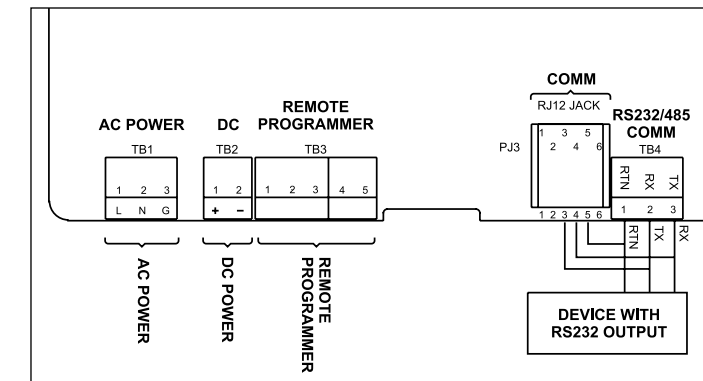

Connect the main power connections as shown in the figure below.

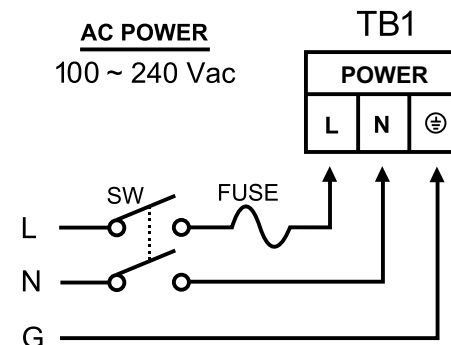

### CONFIGURATION

#### MENU Mode:

Flashing display in MENU Mode means you can make your selection by pressing **⏏** button. If the flashing display is not a four digit value, pressing **⏏** button will always direct the instrument one step backward of the top menu item. The second push on the **⏏** button will reset the instrument except after the setpoint and the alarms, that will go to the RUN Mode without resetting the instrument. The **⏏** button will always sequence the instrument thru the menu items.

#### The **⏏** button has two functions:

- To save a selected flashing display
- To direct the instrument to the next submenu level

#### RUN Mode:

- ⏏** causes the display to flash the PEAK with the corresponding value. Press again to go back to RUN Mode.
- ⏏** causes the display to flash VALLEY with the corresponding value. Press again to go back to RUN Mode.
- ⏏** causes flashing PEAK or VALLEY to reset corresponding values. Pressing **⏏** twice will cause the display to flash **SEtBy** and put the instrument into standby, which disables all outputs and alarms. Press **⏏** one more time to go back to RUN Mode.

#### Button Functions in Configuration Mode

<b>⏏</b> MENU	<ul style="list-style-type: none"> <li>To enter the Menu, the user must first press <b>⏏</b> button.</li> <li>Use this button to advance/navigate to the next menu item. The user can navigate through all the top level menus by pressing <b>⏏</b>.</li> <li>While a parameter is being modified, press <b>⏏</b> to escape without saving the parameter.</li> </ul>
<b>⏏</b> PK/GRS (UP)	<ul style="list-style-type: none"> <li>Press the up <b>⏏</b> button to scroll through "flashing" selections. When a numerical value is displayed press this key to increase value of a parameter that is currently being modified.</li> <li>Holding the <b>⏏</b> button down for approximately 3 seconds will speed up the rate at which the setpoint value is incremented.</li> <li>In the Run Mode pressing <b>⏏</b> causes the display to flash the PEAK or GROSS value – press again to return to the Run Mode.</li> </ul>
<b>⏏</b> TARE (DOWN)	<ul style="list-style-type: none"> <li>Press the down <b>⏏</b> button to go back to a previous Top Level Menu item.</li> <li>Press this button twice to reset the controller to the Run Mode.</li> <li>When a numerical value is flashing (except setpoint value) press <b>⏏</b> to scroll digits from left to right allowing the user to select the desired digit to modify.</li> <li>When a setpoint value is displayed press <b>⏏</b> to decrease value of a setpoint that is currently being modified. Holding the <b>⏏</b> button down for approximately 3 seconds will speed up the rate at which the setpoint value is decremented.</li> <li>In the Run Mode pressing <b>⏏</b> causes the display to flash TARE value to tare your reading (zeroing).</li> </ul>
<b>⏏</b> ENTER	<ul style="list-style-type: none"> <li>Press the enter <b>⏏</b> button to access the submenus from a Top Level Menu item.</li> <li>Press <b>⏏</b> to store a submenu selection or after entering a value — the display will flash a <b>SEtBy</b> message to confirm your selection.</li> <li>To reset flashing PEAK or GROSS press <b>⏏</b>.</li> <li>In the Run Mode, press <b>⏏</b> twice to enable Standby Mode with flashing <b>SEtBy</b>.</li> </ul>



Reset: Except for Alarms, modifying any settings of the menu configuration will reset the meter prior to resuming Run Mode.

### DISPLAY ABBREVIATIONS

SP1	Set Point 1 Value	SP2	Set Point 2 Value
CNFG	Configuration Menu	INPt	Input Type (Range)
INPt	Input Type (range)	0 - 0.1	100 mV Input Voltage
0 - 1.0	1 V Input Voltage	0 - 10	10 V Input Voltage
0 - 20	20 mA Input Current	RESO	Display Resolution
Rtio	Ratiometric Operation	PEAK	Peak Value
bUtN	Button Peak/Gross		
GROS	Gross Value		
RdG	Reading Configuration		
dEC	Decimal Point	F.FFF	Decimal Point Position
		..FFF	Decimal Point Position
LOAd	Input Load	EnbL	Scaling with Known Loads (Actual Value)
DSbL	Scaling without Known Loads (Calculated Value)	L.PNt	Linearization Points
0002..	Number of Linearization Points	FLtR	Filter Constant
..0010	Filter Constant Value	IN.Rd	Input/Reading Scale and Offset Menu
0001..	Filter Constant Value	Rd 1	Reading 1
..0128		Rd 2	Reading 2
IN 1	Input 1	....	....
IN 2	Input 2	....	....
....	....	....	....
IN 10	Input 10	Rd 10	Reading 10
ALR1	Alarm 1 Menu	AbSo	Absolute Mode
dEV	Deviation Mode	Ltch	Latched Mode
UNLt	Unlatched Mode	Ct.CL	Contact Closure
N.o.	Normally Open	N.c.	Normally Closed
ActV	Active Type	AboV	Active Above
bELo	Active Below	Hi.Lo	Above High/Below Low
bANd	Above or Below Band	A.P.oN	AlarmEnable/Disable at Power On
ALR.L	Alarm Low Value	ALR.H	Alarm High Value
ALR.2	Alarm 2 Menu		
SP.dN	Set Point Deviation		
Id	ID Code Menu	CH.Id	Change ID Code
FULL	Full ID	SP.Id	Set Point ID
COMM	Communication Option*	NONE	Communication is Not Installed
C.PAR	Communication Parameters	bAUd	Baud Rate
PrtY	Parity	odd	Odd
EVEN	Even	No	No
dAtA	Data Bit	7.bit	7 Data Bit
8.bit	8 Data Bit	StOP	Stop Bit
1.bit	1 Data Bit	2.bit	2 Stop Bit
bus.F	Bus Format	M.bus	Modbus Protocol
LF	Line Feed	ECHO	Echo
StNd	Communication Standard	232C	RS-232
485	RS-485	ModE	Data Flow Mode
CMd	Command Mode	CoNt	Continuous Mode
SEPR	Data Separation Character	SPCE	Space
cR	Carriage Return	dAt.F	Data Format
stAt	Alarm Status	RdNG	Transmit Reading Value
PEAK	Transmit Peak Value	GROS	Transmit Gross Value
UNIT	Units of Measurement	AddR	Multipoint Address
tR.tM	Transmit Color Selection		
COLR	Display Color Selection	N.CLR	Normal Color Display
1.CLR	Alarm 1 Color Display	2.CLR	Alarm2 Color Display
REd	Display Color is Red	AMbR	Display Color is Amber
GRN	Display Color is Green		
dSbL	Disable	ENbL	Enable
ERRO	Error	+ OL	Input (+) Overload

\* For abbreviations of Communication Option see Communication Manual.