

iR2 ULTRA HIGH PERFORMANCE 2-COLOR RATIO FIBER OPTIC INFRARED TEMPERATURE MEASUREMENT AND CONTROL SYSTEM.



- ✓ 300 to 3000°C (572-5432°F)
- ✓ High Quality
- ✓ 5 Year Warranty
- ✓ Ethernet and RS232/485
- ✓ Full Autotune PID control

5 YEAR
WARRANTY

MADE IN
USA



\$2995
Complete!

The OMEGA iR2™ Series

is the state-of-the-art instrument for difficult and demanding high temperature (300°C-3000°C) applications. It is ideally suited for measurement and control applications involving metals, glass, semiconductors and more. The iR2 is extremely fast and accurate with a response time of 10 msec and accuracy of 0.2% of full scale. Despite its extraordinary technological sophistication and performance, the iR2 is also incredibly user friendly and simple to configure. The iR2 is designed and manufactured in the USA to the highest quality standards backed by a 5 year extended warranty.

2-COLOR RATIO MEASUREMENT

The iR2 measures temperature using a 2-color ratio technique in which a temperature is computed from the ratio of two different infrared frequencies, unlike a standard infrared thermometer that measures the absolute amount of infrared energy.

The 2-color ratio technique is essential for accurate measurements in many common applications: when the target is obscured by smoke or steam, when the target is viewed through a window or screen that reduces energy, or when the emissivity of the target is unknown or changes.

Unlike a standard infrared thermometer that determines an average temperature for everything within its field of view, the iR2 does not require that the target completely fill the lens field of view as long as the temperature of the target is higher than the background or material in the foreground.

This capability allows the iR2 lens to be installed farther from the target, or outside a window or screen as well as more accurately measure temperatures of small and moving targets. The iR2 can also be switched to one-color operation if required.

CAST ALUMINUM or PANEL MOUNT ENCLOSURE

The iR2 is available in two practical packages: The iR2C model is an extremely rugged cast aluminum enclosure (with NEMA 4 rating) that can be mounted on any surface and is powered by 20-36 Vdc. The iR2P model is a 1/8 DIN panel mount package with a NEMA 4 front bezel for rack or cabinet mounting with other instrumentation, and runs on 90-240 Vac/dc power.

FULL PID CONTROL

The iR2 is much more than the typical infrared transmitter. It is a complete autotune PID TEMPERATURE CONTROLLER in a single extremely compact enclosure (an important, unique feature). The iR2 features a totally programmable analog output that can be programmed within a range of 0-10 Vdc or 0-20mA. The analog output is selectable as either a control output or as a calibrated retransmission of the temperature. The iR2 also offers a choice of two Form C (SPDT) Relays or Solid State Relays for controlling or alarms. The control functions feature the full suite of capabilities from simple on-off to full Proportional Integral Derivative (PID) control. Instead of connecting a simple infrared transmitter to a separate temperature controller, the iR2 can do it all.

BIG BRIGHT DISPLAY

The iR2 features a big bright LED dual display. The smaller numbers display the set points or alarm points. The larger numbers (a full 21mm, .83" high) display the measured temperature. The display can be programmed to change color between green, amber and red at any set point or alarm point and the change in color is quickly seen from a distance.



Available Probe Types
L1 Lens Probe
L2 Ceramic/Metal Tip
L3 Polymer Bolt
L4 Ejector Pin Probe

Custom application-specific lens assemblies and fiber optic probes.

FIBER OPTICS

The iR2 comes complete with a compact NEMA 4 lens and a flexible fiber optic cable assembly. With the iR2 it's possible to measure the temperature of targets that would simply not be visible with conventional instruments. The fiber optic cable and lens allows the instrument electronics to be kept away from the target environment where it would be subjected to higher temperatures, smoke, dust, steam or powerful electromagnetic emissions such as generated by induction heating.

Both the stainless steel lens and rugged cable assembly can be replaced in the field without returning the instrument for calibration (a unique feature). The lens can operate in ambient temperatures up to 200°C without external cooling. The variable focus lens can focus on targets from any distance between 200 millimeters (8 inches) to more than 4 meters (14 feet). The 25:1 field of view is ideal for most applications.

OMEGA also offers a wide selection of compatible application-specific lens assemblies and fiber optic probes developed during three decades of experience servicing the most demanding infrared temperature applications.

UNIQUE BUILT IN LASER SIGHT

The iR2 features a built-in laser that shows the operator precisely what the lens is seeing (a unique feature). This innovative laser illuminates the precise spot on the target that the lens is viewing, and allows the operator to focus on the target with absolute precision. The laser can be turned on to sight the target and off to make a measurement with the simple push button on the front panel, or remotely via network or serial communications. The cable and lens do not have to be disconnected and connected to a separate apparatus to provide a conventional or laser light for sighting.

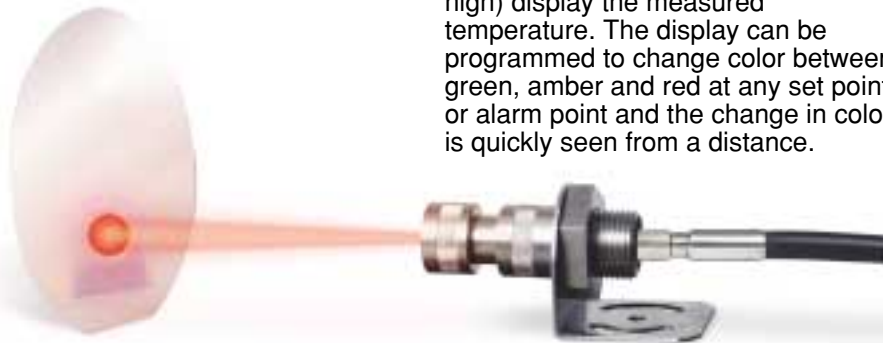

UNIQUE BUILT IN LASER SIGHT

The iR2 features a built-in laser that shows the operator precisely what the lens is seeing

RUGGED CAST ALUMINUM OR PANEL MOUNT ENCLOSURE



**iR2P
1/8 DIN PANEL
MOUNT**

**iR2C
CAST ALUMINUM
ENCLOSURE**



Output Type: Analog voltage or current, Relay, DC Pulse
Analog Output Response: 1 second
Pulse Output Response: 1 second
Laser Sighting: Built-into the Controller for Optical assembly alignment
Wavelength (Color): 650nm (RED)
Operating Distance: 20 cm to 4 m (8" to 14")
Max. Laser Power output: <1mW
Safety Classification: Class 2, complies with FDA 21 CFR 1040.10, CE EN60825-1/11.2001
Laser Power Switch: Set via the Controller Menu
Laser Indicator: Displays on the Controller

SPECIFICATIONS:

Accuracy: 0.2% of Full Scale
Repeatability: 0.2% of Full Scale
Temperature Resolution: 1 Degree
Temperature Range:
 300 to 1300°C (572 to 2372°F)
 single color: 300 to 1300°C
 dual color: 450 to 1300°C
 600 to 1800°C (1112 to 3272°F)
 single and dual color
 1000 to 3000°C (1832 to 5432°F)
 single and dual color
Response time: 10 msec (0 to 63% of final value)
Spectral Response: 0.8 to 1.7 microns
IR Temperature Measurement: Selectable between single and dual color
Emissivity: Adjustable 0.1-1.0 (Single)
Slope: 0.85 – 1.15 (Two Color)
Optical Field of View: 25 : 1, Adjustable Focus from 200 mm to more than 4 meters distance (8"to14')

Laser Beam Diameter: Smallest Spot Size 8 mm (0.32"), Minimal focus distance is 200 mm (8")
Dimensions (Optical Assembly): Ø 20 x 62 mm (Ø 0.79 x 2.43") Maximum Length
Fiber Cable: 1 m included, 2 and 3 m optional (3, 6 and 10').
Power: 90 to 240 Vac for iR2P model; 20-36 Vdc or 24Vac for iR2C model
Operating Ambient temperature:
Controller: 0 to 50°C (32 to 122°F)
Optical Assembly: 0 to 200°C (32 to 392°F), without cooling required
Display: Three Color Dual Display (Amber, Green & Red), Programmable
Environmental Rating: IP65 , NEMA4 (Both the Optical Assembly and the Front Panel)
Serial Communication: RS232 and RS485/422 or Ethernet and RS485/422
Controller: ON / OFF or PID
Controller with Autotune
Outputs: 2 Control or Alarm Outputs

The iR2 can control a process with simple ON-OFF control through full Autotune PID control, and everything in between. The dual control outputs can be configured for a variety of independent control and alarm applications such as heat/heat, heat/cool, heat/alarm, and more. The ramp-to-setpoint feature allows the user to define the rate of rise to setpoint, minimizing thermal shock to the load during start-up.

IR TEMPERATURE METER/CONTROLLER

iR2C

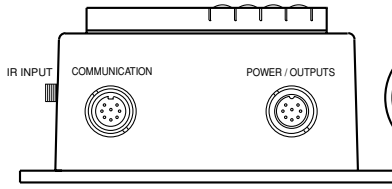

iR2C



- 1 OUTPUT#2 N.O.
- 2 OUTPUT#1 N.C.
- 3 DC (-) RETURN
- 4 OUTPUT#1 COM.
- 5 OUTPUT#1 N.O.
- 6 OUTPUT#2 N.C.
- 7 DC (+)
- 8 OUTPUT#2 COM.

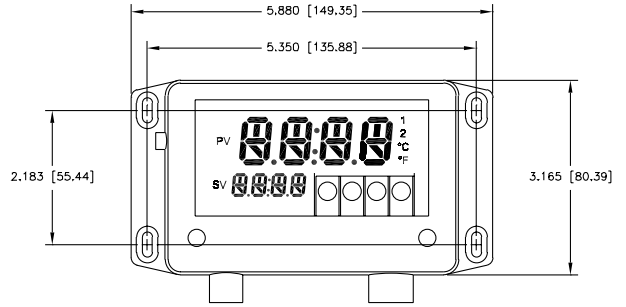

iR2P

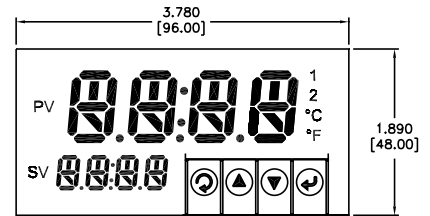
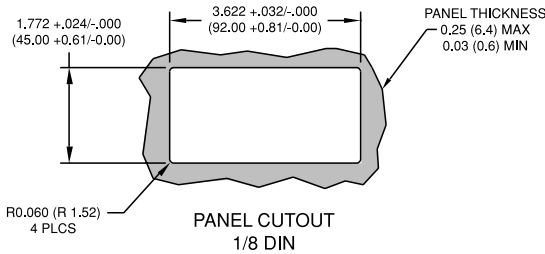
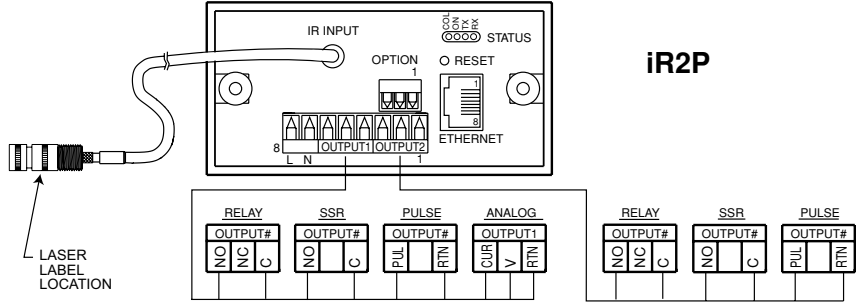
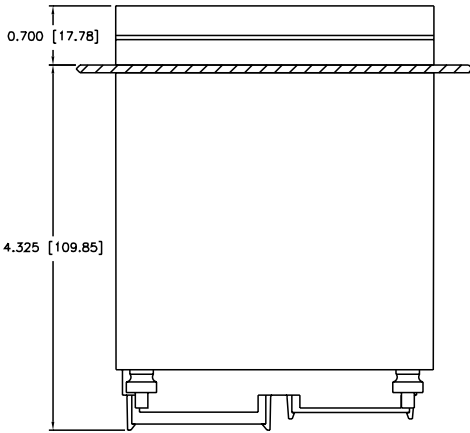

Dimensions shown in inches (mm)

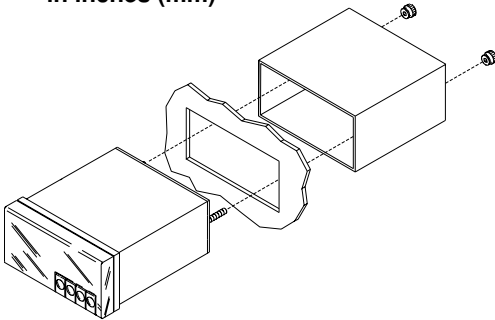

To Order (Specify Model No.)

Model No.	Range	Outputs*	Description	Price
iR2C			Controller: cast aluminum enclosure, 20-36 Vdc powered unit	\$2995
iR2P			Controller: 1/8 DIN Panel mount 90-240 Vac powered unit	\$2995
	-300		300 to 1300°C (572 to 2372°F)	N/C
	-600		600 to 1800°C (1112 to 3272°F)	N/C
	-1000		1000 to 3000°C (1832 to 5432°F)	N/C
		-53	1 Programmable Analog Output selectable as either control or retransmission of the process value, 0-10 Vdc or 4-20mA, plus One (1) SPDT Relay	N/C
		-43	Pulsed 10 Vdc @ 20 mA (for use with external SSR) and relay: Form "C" SPDT 3 A @ 120 Vac, 3 A @ 240 Vac	N/C
		-33	2 Relays: Form "C" SPDT 3 A @ 120 Vac, 3 A @ 240 Vac	N/C

* Other output combinations are available.

NETWORK OPTIONS	Price
-C24 Isolated RS-232 and RS-485/422. 300 to 19.2k Baud (if required)	N/C
-C4EI Ethernet with Embedded Web Server + Isolated RS-485/422/MODBUS	N/C

ORDERING EXAMPLE: iR2C-1000-53-C4EI is a 2-Color Infrared Temperature Controller in a rugged cast aluminum enclosure with optic lens assembly, temperature range 1000 to 3000°C. Programmable Analog Output, 1 SPDT Form C relay, Ethernet, RS-485/422/MODBUS and an iR2-06 6 ft. Fiber Optic Cable, substituted for the standard 3ft cable. \$2995+200 = \$3195

ACCESSORIES	Price
iR2-03 3 ft. Fiber Optic Cable* (for ranges -600 and -1000 only)	\$100
iR2-06 6 ft. Fiber Optic Cable (for ranges -600 and -1000 only)	\$200
iR2-10 10 ft. Fiber Optic Cable (for ranges -600 and -1000 only)	\$300
iR2-30 32.8 ft. (10m) Fiber Optic Cable (for ranges -600 and -1000 only)	\$550
iR2-03Q 3 ft. Fiber Optic Quartz Cable* (for range -300 only)	\$200
iR2-06Q 6 ft. Fiber Optic Quartz Cable (for range -300 only)	\$300
iR2-10Q 10 ft. Fiber Optic Quartz Cable (for range -300 only)	\$400
CAL3-IR2 Calibration traceable to NIST with 5 data points	\$400

* 3 ft. is standard with controller, unless different cable length is selected. Note: Lens assembly supplied with controller.

iSeries DISPLAYS
change color
at any set point*



Totally Programmable Color Displays

