

User's Guide



*<http://www.omega.com>
e-mail: info@omega.com*

LDP-124 AND LDP-144 SERIES

FOR PROCESS SIGNAL



OMEGAnet® On-Line Service
<http://www.omega.com>

Internet e-mail
info@omega.com

Servicing North America:

USA :
ISO 9001 Certified One Omega drive, Box 4047
Stamford, CT 06907-0047
Tel : (203) 359-1660 Fax : (203) 359 7700
e-mail : info@omega.com

Canada : 976 Bergar
Laval (Quebec) H7L 5A1
Tel : (514) 856-6928 Fax : (514) 856-6886
e-mail : info@omega.com

For immediate technical or application assistance:

USA and Canada : Sales Service : 1-800-826-6342 / 1-800-TC-OMEGASM
Customer Service : 1-800-622-2378 / 1-800-622-BESTSM
Engineering Service : 1-800-872-9436 / 1-800-USA-WHENSM
Telex : 996404 EASYLINK : 62968934 CABLE : OMEGA

Mexico and Latin America : Tel : (95) 800-826-6342 Fax : (95) 203-359-7807
En Español : (203) 359-7803 e-mail : espanol@omega.com

Servicing Europe:

Benelux: Postbus 8034, 1180 LA Amstelveen, The Netherlands
Tel : (31) 20 6418405 Fax : (31) 20 6434643
Toll Free in Benelux : 0800 0993344
e-mail : nl@omega.com

Czech Republic : ul. Rude armady 1868, 733 01 Karvina-Hranice
Tel : 420 (69) 6311899 Fax : 420 (69) 6311114
Toll Free : 0800-1-66342 e-mail : czech@omega.com

France : 9, rue Denis Pappin, 78190 Trappes
Tel : (33) 130-621-400 Fax : (33) 130-699-120
Toll Free in France : 0800-4-06342
e-mail : france@omega.com

Germany/Austria : Daimlerstrasse 26, D-75392 Deckenpfronn, Germany
tel : 49 (07056) 3017 Fax : 49 (07056) 8540
Toll Free in Germany : 0130 11 21 66
e-mail : info@omega.de

United Kingdom : One Omega Drive, River Bend Thecnology Centre
ISO 9002 Certified Northbank, Irlam, Manchester
M44 5EX, England
Tel : 44 (161) 777-6611 Fax : 44 (161) 777-6622
Toll Free in the United Kingdom : 0800-488-488
e-mail : info@omega.co.uk

It is the policy of OMEGA to comply with all worldwide safety and EMC/EMI regulations that apply. OMEGA is constantly pursuing certification of its products to the European New Approach Directives. OMEGA will add the CE mark to every appropriate device upon certification.

The information contained in this document is believed to be correct, but OMEGA Engineering, Inc. accepts no liability for any errors it contains, and reserves the right to alter specifications without notice.

WARNING : These products are not designed for use in, and should not be user for, patient connected applications.

CONTENTS

DESCRIPTION	SECTION	PAGE
IMPORTANT SAFETY CONSIDERATIONS	1	3
UNPACKING AND INSPECTION	2	4
MAIN FEATURES	3	5
MODELS	4	6
LDP-1XX-P1		6
LDP-1XX-P2.		6
GENERAL SPECIFICATIONS	5	7
FRONT VIEW, DESCRIPTION	6	7
REAR VIEW, DESCRIPTION	7	7
WIRING	8	8
POWER SUPPLY, RECOMMENDED WIRING	8.1	8
FUSES	8.2	8
MODEL P1	8.3	8
MODEL P2	8.4	8
CONTROL BOARDS & SIGNAL CONDITIONER, LOCATION	9	9
SIGNAL INPUT, SPAN & OFFSET RANGE SELECTION	10	9
INSTRUMENT LDP-1XX-P1 (SIGNAL CONDITIONER MODEL MB-32)	10.1	9
INSTRUMENT LDP-1XX-P2 (SIGNAL CONDITIONER MODEL MB-36/A)	10.2	10
ADJUSTMENT AND CALIBRATION PROCEDURE	11	10
INSTALLATION	12	11
MECHANICAL DIMENSIONS	13	11
WARRANTY		12
OTHER PRODUCTS		13

1.- IMPORTANT SAFETY CONSIDERATIONS

INSTALLATION

PRECAUTIONS.-

The installation and the future use of this unit must be done by suitable qualified personnel.

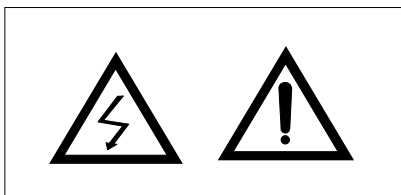

The unit has not AC (mains) switch, it will be in operation as soon as power is connected. The installation must incorporate an external main switch.

The unit has a protection fuse incorporated on the AC socket, if it is necessary to change or replace, use the time-lag fuse according IEC 127/2 and the values indicated below.

200 mA when the unit is operating at 230 Vac
400 mA when the unit is operating at 115 Vac.

Install also the necessary devices to protect the operator and the process when using the unit to control a machine or process where injury to personnel or damage to equipment or process, may occur as a result of failure of the unit.

See paragraph 8, WIRING and paragraph 10, SIGNAL INPUT, SPAN & OFFSET RANGE SELECTION and check that all jumpers are on the correct position.

SAFETY PRESCRIPTIONS.-

The unit has been designed and tested under EN-61010-1 rules and is delivered in good condition. This operator's manual contains useful information for electrical connections. Do not make wiring signal changes or connections when power is applied to the unit. Make signal connections before power is applied and, if reconnection is required, disconnect the AC (mains) power before such wiring is attempted.

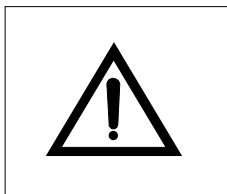

Install the unit in places with a good ventilation to avoid the excessive heating. And far from electrical noise source or magnetic field generators such as power relays, electrical motors, speed controls etc...

The unit cannot be installed in open places. Do not use until the installation is finished.

POWER SUPPLY.-

The power supply must be connected to the adequate terminals (see the connection instructions). The characteristics of the power supply are showed on the label on the rear part. Please make sure that the unit is correctly connected to a power supply of the correct voltage and frequency.

Do not use other power supply otherwise permanent damage may be caused to the unit.

Do not connect the unit to power sources heavily loaded or to circuits which power loads in cycle ON-OFF or to circuits which power inductive loads.

SIGNAL WIRING.-

Certain considerations must be given when install the signal input and control wires. If the wires are long can act like an antenna and introduce the electrical noise to the unit, therefore :

Do not install the signal input wires in the same conduit with power lines, heaters, solenoids, SCR controls etc....and always far from these elements.

When shielded wires are used, connect the shield to the common terminal and leave unconnected the other end of the shield and do not connect to the machine ground.

EXCITATION SUPPLY V_{exc}.-

Models P1 and P2 supply the excitation voltage adjustable from 10 to 24 Vdc @ 50 mA to power pressure transducers or other types of transducers.

Do not connect the V_{exc}. output terminal to other external power supply, permanent damages may result to the unit.

SAFETY CONSIDERATIONS

PRESCRIPTIONS.-

Before starting any operation of adjustment, replacement, maintenance or repair, the unit must be disconnected from any kind of power supply.

Keep the unit clean, to assure good functioning and performance. Use for it a clean and humid rag. Do not use for the frontal lens abrasive products, solvents, alcohol, etc... because its transparence could be damaged and this may cause difficulty for a correct vision

of the reading.

To prevent electrical or fire hazard, do not expose the unit to excessive moisture.

Do not operate the unit in the presence of flammable gases or fumes, such as environment constitutes a definite

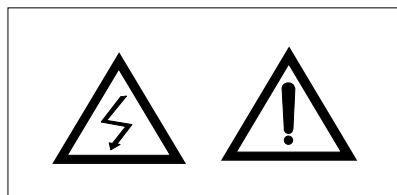

safety hazard. The unit is designed to be mounted in a metal panel.

If the unit shows signs of damage, or is not able to show the expected measures, or has been stored in a bad conditions or a protection failure can occur, then do not attempt to operate and keep the unit out of service.

IN CASE OF FIRE

- 1.- Disconnect the unit from the power supply.
- 2.- Give the alarm according to the local rules.
- 3.- Switch off all the air conditioning devices.
- 4.- Attack the fire with carbonic snow, do not use water in any case.

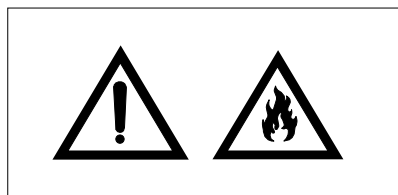

WARNING : In closed areas do not use systems with vaporized liquids.

CONNECTIONS

All wiring connections are made using push-in cable connectors. There is a separate connector block for power supply and input signals. Please make sure that each connector block is connected on the adequate place.

The wire cross section recommended for signal inputs is 1 mm² and for power supply 2.5 mm².

PANEL MOUNTING

Verify that the panel cut-out is correctly according to the dimensions indicated on page 11 with a minimum depth of 150 mm. (5.9"). Install the fixation pieces in the lateral guides of the unit by its rear part and then turn the screw firmly against the panel, until the unit is totally hold on.

2.- UNPACKING AND INSPECTION

It is advisable to do a detailed reading of this Manual before mounting the instrument. This Operator's Manual contains all the technical specifications : electricals as well as mechanics, both necessary to do a correct installation and also a good use of the instrument.

At the same time the user will acquire the knowledge needed to obtain the best performances of the product.

Check that inside the present cardboard box, there are the following :

- 1 Instrument Model LDP-1XX-P1 or P2.
- 1 Operator's Manual.
- 1 Connector for Power Supply.
- 1 Screw-clamp connectors, 4 pins female for signal inputs.
- 2 Pieces for fixing the unit against the panel.

REFERENCE KEY

All models have a label on the rear part with their references printed on the following format :

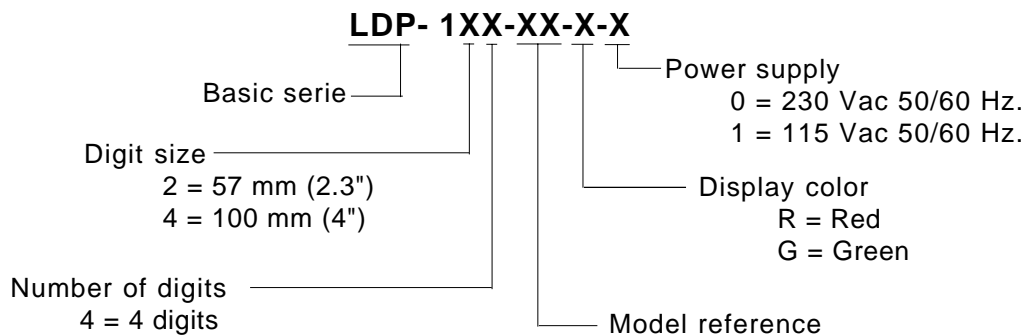

If there are some doubts or inquiries about the present instrument, please contact **OMEGA ENGINEERING'S customer service department**.

When the shipment arrives remove the Packing List and verify that you have received all equipment. Then inspect the box and the instrument, and if there is evidence of damage caused by bad handling during the transport, it is advisable to make a careful inspection of all damages making a note of all of them and to pass on this information directly to the Transport Company.

If this occurs but with insured material, ask the Transport Company for instructions about submitting a claim.

3.- MAIN FEATURES

On this paragraph is detailed the main features for every one of the series which are the following :
Instruments of four digits plus polarity (only minus) to show process signals generated by Tachogenerators, Converters, Pressure transducers, Transmitters or any process signal in DC voltage or current.
These two models allow to display any reading in engineering units for any DC voltage or current input.
Models P1 and P2 allow the user the Zero displacement for signals such as 4...20 mA, 1...5 Vdc, etc...

Serie LDP-124-XX : 4 digits type LED, seven segments, red or green colour with 57 mm (2.3") height and minus sign for polarity.

Serie LDP-144-XX : 4 digits type LED, seven segments, red or green colour with 100 mm (4") height and minus sign for polarity.

The complete reference for each instrument is obtained replacing the XX by the corresponding reference of each model.

The common features for all series are the following:

MECHANICAL.-

Housed in a rugged extruded aluminium profile housing for panel mounting or free standing.
Finished in anodized black colour. The frontal lens is mounted with a special rubber profile which provides the front part of the unit with an IP-65 protection.

CONNECTIONS.-

Connections for Signal Inputs are made using one screw-clamp connector of four terminals located on the rear part of the unit.

The recommended wire cross section for signal input is 1 mm².

Connection for Power Supply uses a push-in cable connector with 2 terminals for power and 1 terminal for earth.

The fuse is located in the Power Supply socket, as well as the spare fuse.

4.- MODELS

LDP-1XX-P1

Indicator for the most popular process signals in current or voltage such as 4...20 mA, 1...5 V., etc,... 10 of these process signals can be selected on the signal conditioner using plug-in jumpers. See paragraph 10.1

However if your signal input is not indicated on the table but is within one of them, then select this value and adjust the instrument following the calibration procedure. For example for 0...15 mA select the signal input as 0...20 mA; for 5...18 mA. select the signal input as 4...20 mA.

Reading on the display can be scaled to any value in engineering units, selecting the adequate Span range on the signal conditioner and using the trimmer PT1. Jumpers to select Span range and trimmer PT1 are located on the signal conditioner.

The control board for this model is provided with trimmer P3 and the necessary circuitry to obtain the displacement of the Zero. It has 3 selectable ranges using plug-in jumpers located on the signal conditioner.

The reading on the display for the low level signal input can be displaced 10000 counts in positive or negative.

Overrange function will be activated if reading is over 9999 and display will start to flash.

LDP-1XX-P2

Indicator for process signals up to 200 Vdc. with four selectable ranges on the signal conditioner by plug-in jumpers. See paragraph 10.2.

Reading on the display can be scaled to any value in engineering units, selecting the adequate Span range and using the trimmer PT1.

However if your signal input is not indicated on the table but is within one of them, then select this value and adjust the instrument following the calibration procedure. For example for 0...15 V. or 2...20 V. select the signal input as 0...100 V.

Reading on the display can be scaled to any value in engineering units selecting the adequate Span range on the signal conditioner and using the trimmer PT1.

Jumpers to select Span range and trimmer PT1 are located on the signal conditioner.

The control board for this model is provided with trimmer P3 and the necessary circuitry to obtain the displacement of the zero. It has 3 selectable ranges using plug-in jumpers located on the signal conditioner.

The reading on the display for the low level signal input can be displaced 10000 counts in positive or negative.

Overrange function will be activated if reading is over 9999 and display will start to flash.

NOTE : If the instrument can not be adjusted at the reading desired for the signal input applied, please contact factory for instructions.

5.- GENERAL SPECIFICATIONS

DISPLAY

TYPE	4 digits, 7 segments, red or green LED.
HEIGHT DIGIT	57 mm. (2.3") or 100 mm. (4").
RANGE	-9999 a 9999
POLARITY	Minus only (-).
OVERRANGE	Display flashing.
DECIMAL POINT	Jumper selectable.

ANALOG-to-DIGITAL CONVERSION

INPUT CONFIGURATION	Single ended.
TECHNIQUE	Dual slope, average value.
POLARITY	Automatic, only minus sign.
SIGNAL INTEGRATION PERIOD ..	100 ms.
READ RATE	2.5/s.
OSCILLATOR	400 KHz. quartz crystal.

ACCURACY for both models . . . [(0,1 % FS of the Offset range selected) + (0,1 % FS of the Span selected)] ±1 digit.

ENVIRONMENTAL

OPERATING TEMPERATURE	0 to +50 °C (32 to 122 °F).
STORAGE TEMPERATURE ..	-20 to +85 °C (-4 to 185 °F).
RELATIVE HUMIDITY	0 to 85 % not condensed.
PROTECTION	IP65. (Front part only).

MECHANICAL

DIMENSIONS	See table in page 11.
PANEL CUT OUT	See table in page 11
DEPTH	See table in page 11.
WEIGHT	See table in page 11.
CASE MATERIAL	Aluminium extruded.
FINISHED	Anodized, black colour.

ELECTRICAL

STANDARD POWER SUPPLY	115 Vac. ±10% 50 / 60 Hz. (Optionally 230 Vac)
POWER CONSUMPTION	See table in page 11.
VOLTAGE OUTPUT FOR TRANSDUCERS	10...24 Vdc @50 mA

6.- FRONT VIEW, for both series

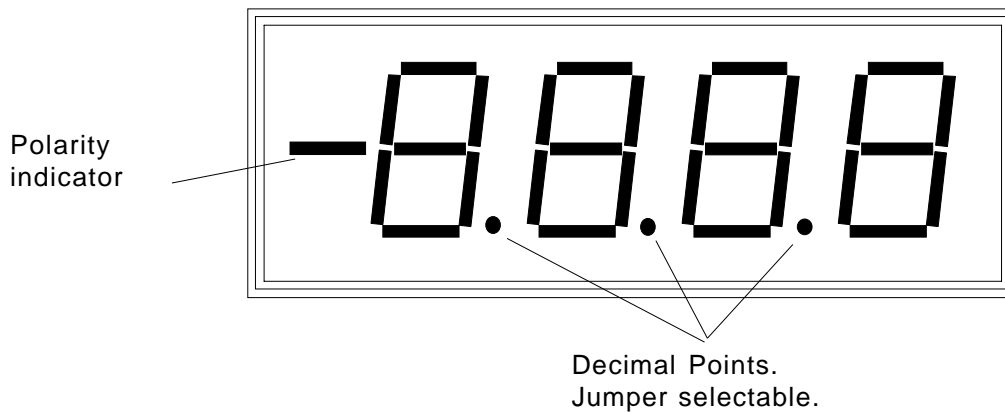

7.- REAR VIEW, for both series

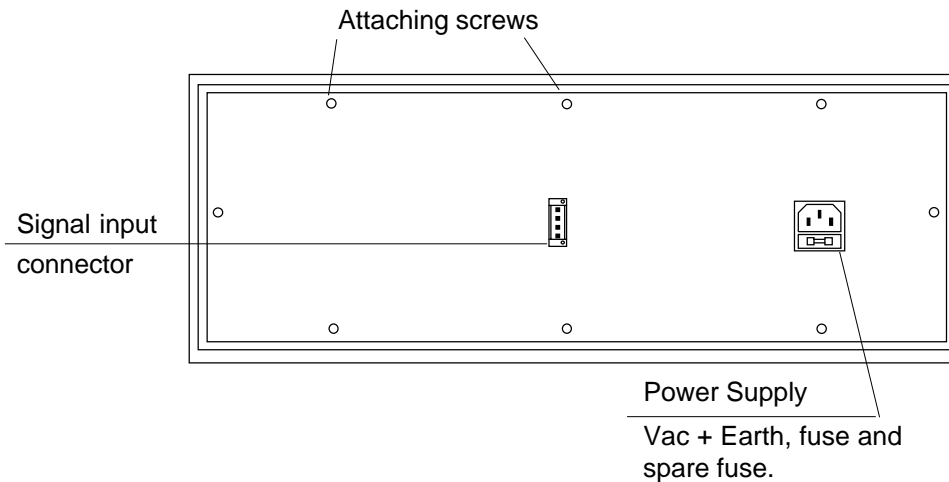

9.- CONTROL BOARD & SIGNAL CONDITIONER, location

Control board is installed inside the instrument behind the display circuit and it is accessible only when the rear cover is open. Only authorised personnel can open the instrument, because personnel injury can occur due to the high internal voltage.

Control board is mounted in horizontal position on instruments series LDP-124 and in vertical position on instruments series LDP-144.

Installation on LDP-124 shown.

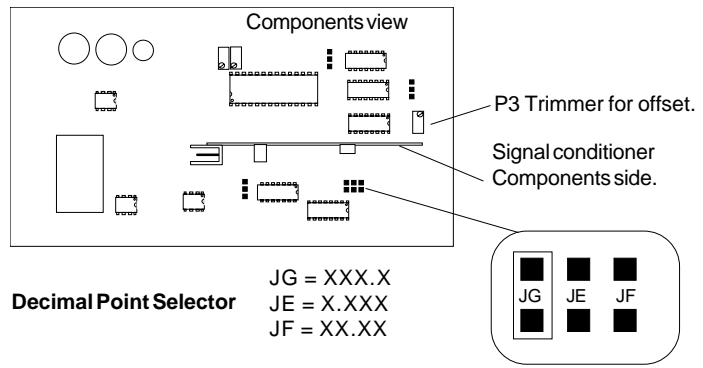

The control board has the Analog/Digital converter, Offset trimmer, Signal Conditioner and jumpers to select the decimal point on three different positions.

Trimmer for Offset (P3) is located on the control board near the signal conditioner, see the above figure. It allows the operator to adjust the Zero for the low level signal or displace the Zero in positive or negative range.

The function of the Signal Conditioner is amplifier or divide the signal received to provide the A/D converter with a maximum signal of 1 V. (10,000 counts). It contains all necessary jumpers to select the most popular process signals and three ranges for Span and Offset.

The signal conditioner has two trimmers. One, trimmer PT1, allows the operator to adjust the Span range to obtain the maximum reading available. The other, trimmer PT3, allows to adjust the voltage excitation output from 10 to 24 Vdc. Factory set-up is 24 Vdc.

There is one signal conditioner for every model.

10.- SIGNAL INPUT, SPAN AND OFFSET RANGE SELECTION

10.1.- INSTRUMENT LDP-1XX-P1 (SIGNAL CONDITIONER MODEL MB-32)

Close jumpers on S1 & S2 selectors according to the signal input.

Use jumpers on S3 selector for Span and Offset range selection.

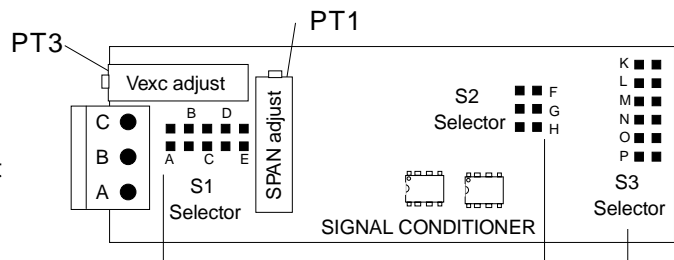

SIGNAL INPUT SELECTION

Signal Input	Close Jumpers	Input Impedance	I _{max.} mA.
0...1 V.	E, G	1.1 MΩ	----
0...5 V.	E, F, G	1.1 MΩ	----
1...5 V.	E, F	1.1 MΩ	----
0...1 mA.	A, D, G	100 Ω	35
0...5 mA.	A, D, F, G	100 Ω	35
1...5 mA.	A, D, F	100 Ω	35
0...20 mA.	A, C, F, G	24.9 Ω	70
4...20 mA.	A, C, F	24.9 Ω	70
0...50 mA.	A, B, F, G	10 Ω	100
10...50 mA.	A, B, F	10 Ω	100

SPAN RANGE

Display Reading	Close Jumper
0 to 5000	K
5000 to 10000	---
10000 to 20000	L

OFFSET RANGE

Display Reading	Close Jumper
0 to 2500	P
2500 to 5000	---
5000 to 10000	N

OFFSET RANGE

If the display reading for the low level signal must be Zero or in negative range, then close jumper marked **M**, but if the reading must be in positive range, then open jumper M and close jumper marked **O**.

i.e.: For a signal input 4...20 mA : Display reading 0...4000, close jumper M.

Display reading -100...4000, close jumper M.

Display reading 100...4000, close jumper O.

10.2.- INSTRUMENT LDP-1XX-P2 (SIGNAL CONDITIONER MODEL MB-36/A)

Close jumpers on S1 & S2 selectors according to the signal input.
Use jumpers on S3 selector for Span and Offset range selection.

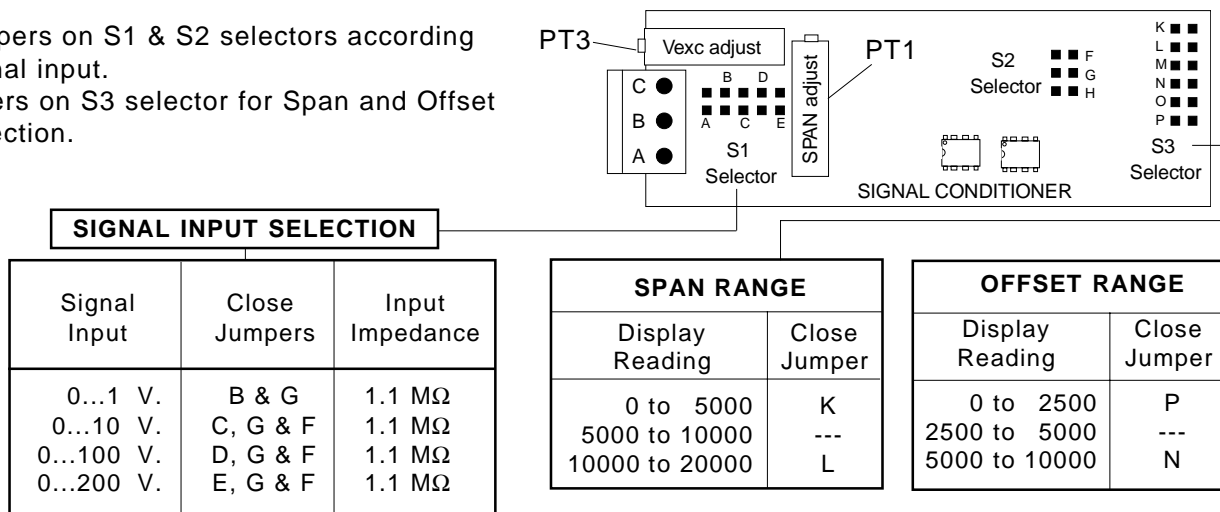

OFFSET RANGE

If the display reading for the low level signal must be Zero or in negative range, then close jumper marked **M**, but if the reading must be in positive range, then open jumper M and close jumper marked **O**.

i.e.: For a signal input 0...10 Vdc : Display reading 0...4000, close jumper M.

Display reading -100...4000, close jumper M.

Display reading 100...4000, close jumper O.

11.- ADJUSTMENT AND CALIBRATION PROCEDURE

Follow the same calibration procedure for model **LDP-1XX-P1** and for model **LDP-1XX-P2**

- 1.- Check that the instrument is not powered.
- 2.- Connect the current or voltage generator to the signal input connector (See paragraph 8.3 or 8.4).
- 3.- Remove the rear cover taking off all the screws to obtain access to the control board. (See page 7 paragraph 7).
- 4.- Remove all jumpers on the signal conditioner. (See paragraph 10)
- 5.- Close jumpers corresponding to the signal input selected, Span and Offset.
- 6.- Power-up the instrument with the appropriate power supply and wait until 3 minutes before to start the adjust.
- 7.- Adjust the current or voltage generator until generate the low signal level.
- 8.- Turn the trimmer P3 located on the Circuit Board until display shows the value corresponding to the low signal level.
- 9.- Adjust the current or voltage generator until generate the high signal level.
- 10.- Turn the trimmer PT1 located on the Signal Conditioner until display shows the value corresponding to the high signal level.
- 11.- Repeat steps 8 to 10 until both values are correct.
- 12.- Check that the linearity remains correct, testing some other points of the range.
- 13.- Check the voltage excitation output connecting a digital voltmeter to the signal input connector (rear cover) terminals A and C.
- 14.- Turn the trimmer PT3 if it necessary to adjust the voltage excitation to the desired value.

12.- INSTALLATION

- 1.- Prepare a panel cut-out with the dimensions indicated on paragraph 13.
- 2.- Slide the instrument (1) into the cut-out.
- 3.- Slide the two fixation pieces (3) with T shape by both lateral sides of the instrument, such as it is shown on the drawing below.
- 4.- Turn the screw bolt until it is pressed firmly against the panel (4) and the instrument (1) remains totally fixed.
- 5.- The front part of the instrument has the necessary elements to provide an IP 65 protection. If the panel where this instrument must be installed, it must to comply some protection standards against water splashes, then a rubber profile (5) on the place indicated and shown on the drawing below.

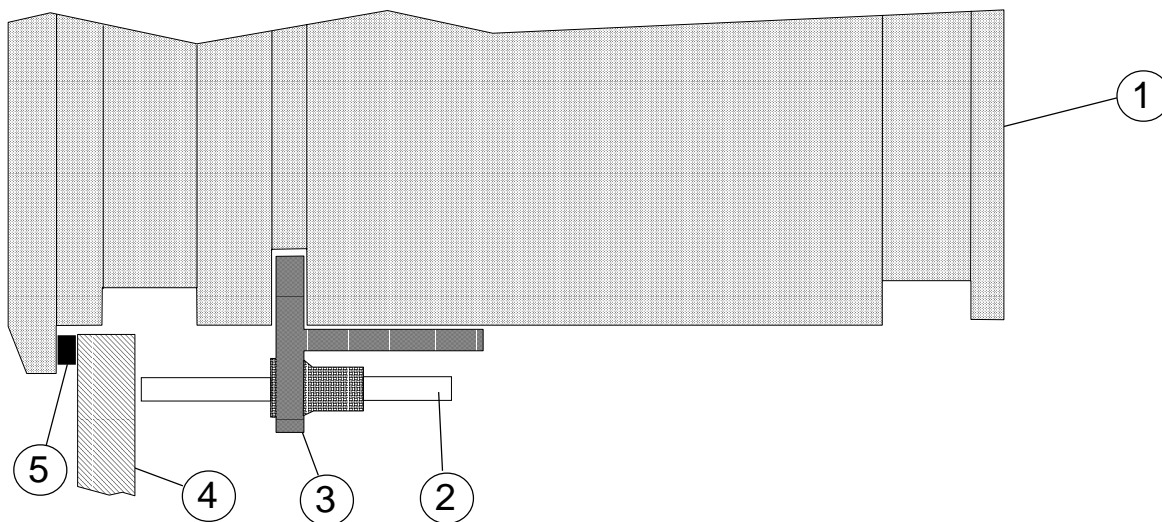

13.- MECHANICAL DIMENSIONS mm (inches)

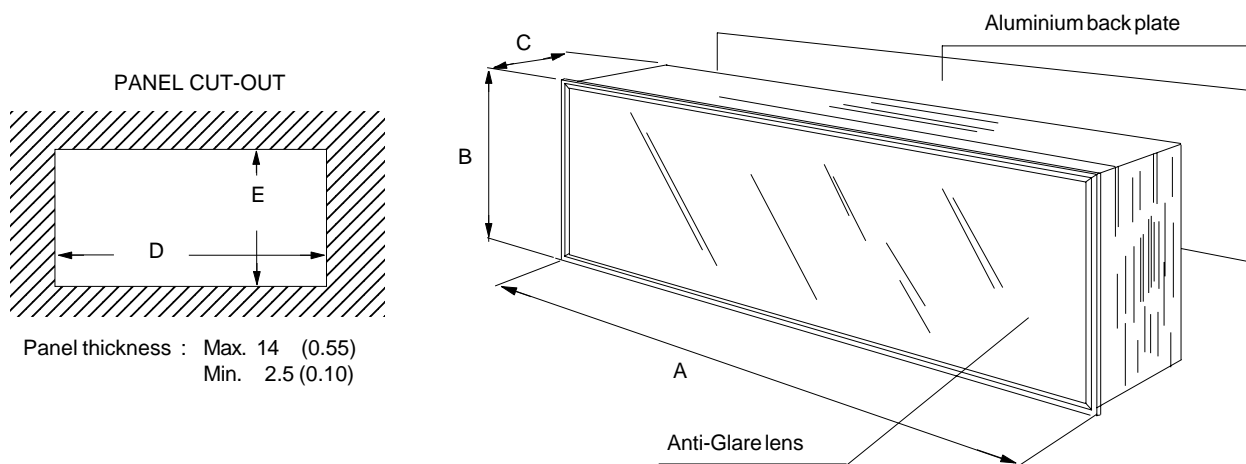

		DIMENSIONS			PANEL CUT-OUT		WEIGHT	POWER
Digits	Height	A	B	C	D	E		
4	57 (2.3)	264 (10.4)	120 (4.75)	112 (4.41)	256 (10.07)	112 (4.4)	2.3 Kg (5 lbs)	6 VA
4	100 (4)	480 (18.9)	180 (7.09)	112 (4.41)	472 (18.58)	172 (6.77)	5 Kg (11 lbs)	12 VA

Dimensions in mm. Parenthesis are in inches or pounds.
Add 27 mm (1.1) to the dimension C for power connector.

WARRANTY/DISCLAIMER

OMEGA ENGINEERING, INC. warrants this unit to be free of defects in materials and workmanship for a period of **13 months** from date of purchase. OMEGA warranty adds an additional one (1) month grace period to the normal **one (1) year product warranty** to cover handling and shipping time. This ensures that OMEGA's customers receive maximum coverage on each product.

If the unit malfunction, it must be returned to the factory for evaluation. OMEGA's Customer Service Department will issue an Authorized Return (AR) number immediately upon phone or written request. Upon examination by OMEGA, if the unit is found to be defective it will be repaired or replaced at no charge. OMEGA's WARRANTY does not apply to defects resulting from any action of the purchaser, including but not limited to mishandling, improper interfacing, operation outside of design limits, improper repair, or unauthorized modification. This WARRANTY is VOID if the unit shows evidence of having been tampered with or shows evidence of having been damaged as a result of excessive corrosion; or current, heat, moisture or vibration; improper specification; misapplication; misuse or other operating conditions outside of OMEGA's control. Components which wear are not warranted, including but not limited to contact points, fuses and triacs.

OMEGA is pleased to offer suggestions on the use of its various products. However OMEGA neither assumes responsibility for any omissions or errors nor assumes liability for any damages that result from the use of its products in accordance with information provided by OMEGA, either verbal or written. OMEGA warrants only that the parts manufactured by it will be as specified and free of defects. OMEGA MAKES NO OTHER WARRANTIES OR REPRESENTATIONS OF ANY KIND WHATSOEVER, EXPRESS OR IMPLIED, EXCEPT THAT OF TITLE, AND ALL IMPLIED WARRANTIES INCLUDING ANY WARRANTY OF MERCHANTABILITY AND FITNESS FOR A PARTICULAR PURPOSE ARE HEREBY DISCLAIMED.

LIMITATION OF LIABILITY: The remedies of purchaser set forth herein are exclusive, and the total liability of OMEGA with respect to this order, whether based on contract, warranty, negligence, indemnification, strict liability or otherwise, shall not exceed the purchase price of the component upon which liability is based. In no event shall OMEGA be liable for consequential, incidental or special damages.

CONDITIONS: Equipment sold by OMEGA is not intended to be used, nor shall it be used: (1) as a "Basic Component" under 10 CFR 21 (NRC), used in or with any nuclear installation or activity; or (2) in medical applications or used on humans. Should any Product(s) be used in or with any nuclear installation or activity, medical application, used on humans, or misused in any way. OMEGA assumes no responsibility as set forth in our basic WARRANTY/DISCLAIMER language, and, additionally, purchaser will indemnify OMEGA and hold OMEGA harmless from any liability or damage whatsoever arising out of the use of the Product(s) in such a manner.

RETURN REQUESTS/INQUIRIES

Direct all warranty and repair requests/inquiries to the OMEGA Customer Service Department. BEFORE RETURNING ANY PRODUCT(S) TO OMEGA, PURCHASER MUST OBTAIN AN AUTHORIZED RETURN (AR) NUMBER FROM OMEGA'S CUSTOMER SERVICE DEPARTMENT (IN ORDER TO AVOID PROCESSING DELAYS). The assigned AR number should then be marked on the outside of the package and on any correspondence.

The purchaser is responsible for shipping charges, freight, insurance and proper packaging to prevent breakage in transit.

FOR **WARRANTY** RETURNS, please have the following information available BEFORE contacting OMEGA:

1. Purchase Order number under which the product was PURCHASED,
2. Model and serial number of the product under warranty, and
3. Repair instructions and/or specific problems relative to the product.

FOR **NON-WARRANTY** REPAIRS, consult OMEGA for current repair charges. Have the following information available BEFORE contacting OMEGA:

1. Purchase Order number to cover the COST of the repair,
2. Model and serial number of the product, and
3. Repair instructions and/or specific problems relative to the product.

OMEGA's policy is to make running changes, not model changes, whenever an improvement is possible. This affords our customers the latest in technology and engineering.

OMEGA is a registered trademark of OMEGA ENGINEERING, INC.

© Copyright 1998 OMEGA ENGINEERING, INC. All rights reserved. This document may not be copied, photocopied, reproduced, translated, or reduced to any electronic medium or machine-readable form, in whole or in part, without prior written consent of OMEGA ENGINEERING, INC.

Where Do I Find Everything I Need for Process Measurement and Control? OMEGA...Of Course!

TEMPERATURE

- Thermocouple, RTD & Thermistor Probes, Connectors, Panels & Assemblies
- Wire: Thermocouple, RTD & Thermistor
- Calibrators & Ice Point References
- Recorders, Controllers & Process Monitors
- Infrared Pyrometers

PRESSURE, STRAIN AND FORCE

- Transducers & Strain Gauges
- Load Cells & Pressure Gauges
- Displacement Transducers
- Instrumentation & Accessories

FLOW/LEVEL

- Rotameters, Gas Mass Flowmeters & Flow Computers
- Air Velocity Indicators
- Turbine/Paddlewheel Systems
- Totalizers & Batch Controllers

pH/CONDUCTIVITY

- pH Electrodes, Testers & Accessories
- Benchtop/Laboratory Meters
- Controllers, Calibrators, Simulators & Pumps
- Industrial pH & Conductivity Equipment

DATA ACQUISITION

- Data Acquisition & Engineering Software
- Communications-Based Acquisition Systems
- Plug-in Cards for Apple, IBM & Compatibles
- Datalogging Systems
- Recorders, Printers & Plotters

HEATERS

- Heating Cable
- Cartridge & Strip Heaters
- Immersion & Band Heaters
- Flexible Heaters
- Laboratory Heaters

ENVIRONMENTAL MONITORING AND CONTROL

- Metering & Control Instrumentation
- Refractometers
- Pumps & Tubing
- Air, Soil & Water Monitors
- Industrial Water & Wastewater Treatment
- pH, Conductivity & Dissolved Oxygen Instruments

M3193 / 1298