

CE

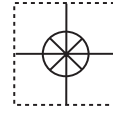

User's Guide

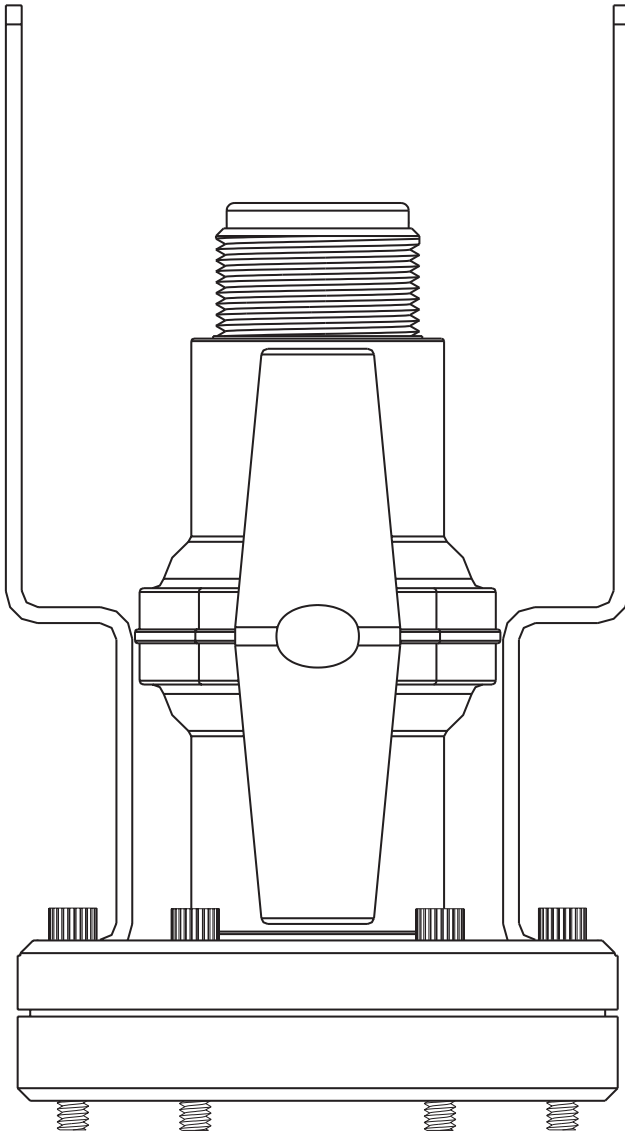

Shop online at

omega.com™

Ω OMEGA®

www.omega.com

e-mail: info@omega.com

ISO 9001

CERTIFIED
CORPORATE QUALITY

STAMFORD, CT

ISO 9002

CERTIFIED
CORPORATE QUALITY

MANCHESTER, UK

FP-319 Flow Wet-Tap Assembly



OMEGAnet® Online Service www.omega.com	Internet e-mail info@omega.com
---	---

Servicing North America:

USA: One Omega Drive, P.O. Box 4047
ISO 9001 Certified Stamford CT 06907-0047
TEL: (203) 359-1660 FAX: (203) 359-7700
e-mail: info@omega.com

Canada: 976 Bergar
Laval (Quebec) H7L 5A1
TEL: (514) 856-6928 FAX: (514) 856-6886
e-mail: info@omega.ca

For immediate technical or application assistance:

USA and Canada: Sales Service: 1-800-826-6342 / 1-800-TC-OMEGA®
Customer Service: 1-800-622-2378 / 1-800-622-BEST®
Engineering Service: 1-800-872-9436 / 1-800-USA-WHEN®
TELEX: 996404 EASYLINK: 62968934 CABLE: OMEGA

Mexico: En Español: (001) 203-359-7803 e-mail: espanol@omega.com
FAX: (001) 203-359-7807 info@omega.com.mx

Servicing Europe:

Benelux: Postbus 8034, 1180 LA Amstelveen, The Netherlands
TEL: +31 (0)20 3472121 FAX: +31 (0)20 6434643
Toll Free in Benelux: 0800 0993344
e-mail: nl@omega.com

Czech Republic: Rudé armády 1868, 733 01 Karviná 8
TEL: +420 (0)69 6311899 FAX: +420 (0)69 6311114
Toll Free: 0800-1-66342 e-mail: czech@omega.com

France: 9, rue Denis Papin, 78190 Trappes
TEL: +33 (0)130 621 400 FAX: +33 (0)130 699 120
Toll Free in France: 0800-4-06342
e-mail: france@omega.com

Germany/Austria: Daimlerstrasse 26, D-75392 Deckenpfronn, Germany
TEL: +49 (0)7059 9398-0 FAX: +49 (0)7056 9398-29
Toll Free in Germany: 0800 639 7678
e-mail: germany@omega.com

United Kingdom: One Omega Drive, River Bend Technology Centre
ISO 9002 Certified Northbank, Irlam, Manchester
M44 5EX United Kingdom
TEL: +44 (0)161 777 6611 FAX: +44 (0)161 777 6622
Toll Free in United Kingdom: 0800-488-488
e-mail: sales@omega.co.uk

It is the policy of OMEGA to comply with all worldwide safety and EMC/EMI regulations that apply. OMEGA is constantly pursuing certification of its products to the European New Approach Directives. OMEGA will add the CE mark to every appropriate device upon certification.

The information contained in this document is believed to be correct, but OMEGA Engineering, Inc. accepts no liability for any errors it contains, and reserves the right to alter specifications without notice.

WARNING: These products are not designed for use in, and should not be used for, patient-connected applications.

OMEGA FP-319 Flow Wet-Tap Assembly

WARNING!



SAFETY INSTRUCTIONS

1. The FP-319 Flow Wet-Tap Valve may only be installed into, and removed from, non-pressurized systems (0 psig).
2. System pressure must be 25 psi or less prior to sensor insertion or removal.
3. Stay clear of sensor stroke area and safety cable during sensor removal.
4. Confirm chemical compatibility before use.
5. Do not exceed maximum temperature/pressure specifications.
6. Wear safety goggles or faceshield during installation/service.
7. Do not alter product construction.

Failure to follow safety precautions may result in severe personal injury!

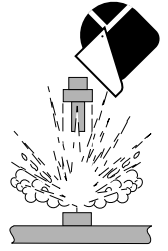

1. Wet-Tap Valve Installation

The OMEGA FP-319 Flow Wet-Tap Assembly attaches directly to OMEGA installation fittings to enable flow sensor removal without system shutdown. It consists of a flange and support plate which thread onto the pipe fitting insert, and a PVC ball valve through which an extended length flow sensor is inserted into the pipe.



Caution: The FP-319 Flow Wet-Tap Valve may only be installed into, and removed from, non-pressurized systems (0 psig).

Procedure

1. Remove six hex nuts and bolts from the Wet-Tap flange. Separate the support plate from the main assembly. Be sure that the Viton O-ring is properly seated in the support plate groove.
2. Apply sealant to the pipe fitting insert threads to prevent leaks.
3. Screw support plate onto pipe fitting insert (O-ring side facing up). It must be threaded completely down until the notches at the top of the pipe fitting insert are exposed.
4. Mount the main Wet-Tap Assembly on the support plate. Make certain the alignment keys on the flange mate with the notches on the pipe fitting insert.
5. Loosen support plate (holding the main Wet-Tap Assembly in place) until it resists slightly. Loosen an additional 1/4-turn to seat O-ring.
6. Replace the six hex nuts and bolts to secure the Wet-Tap Assembly in place. Adjust the support plate position as necessary to align screws.
7. Check the pressure relief plug on Wet-Tap Assembly. It must be closed finger tight to prevent leaks.
8. Close ball valve by turning the handle to the fully closed position (parallel with pipe).

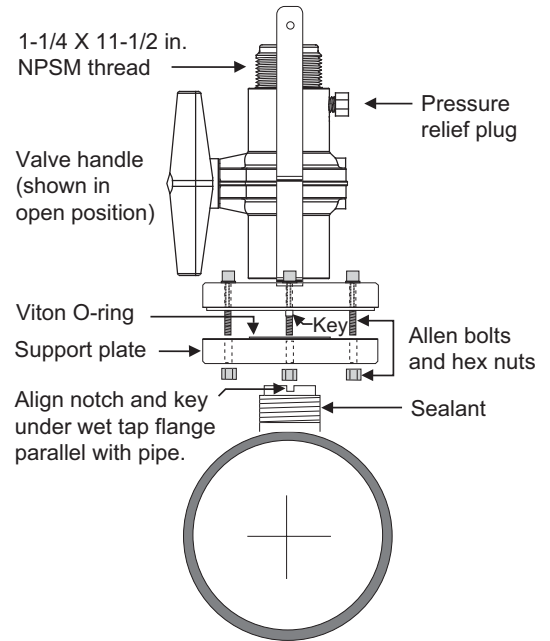

2. Specifications

Materials

- Body: PVC
- Ball seat: PTFE
- O-rings: FPM

Standards

- Manufactured under ISO 9001 and 14001

Fluid Conditions

Pressure/Temperature Ratings:

- 7 bar max. @ -18 to 20°C (100 psi max. @ 0 to 68°F)
- 1.4 bar max. @ 66°C (20 psi max. @ 150°F)

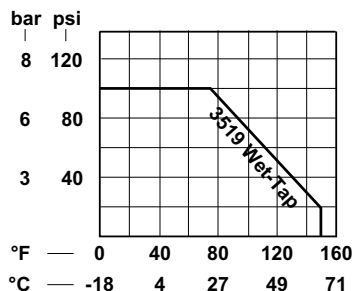

Dimensions

Total minimum clearance for sensor insertion and removal:

- 1/2 to 4 inch pipe: 737 mm (29 inches)
- 5 to 8 inch pipe: 762 mm (30 inches)
- 10 inch and up: 813 mm (32 inches)

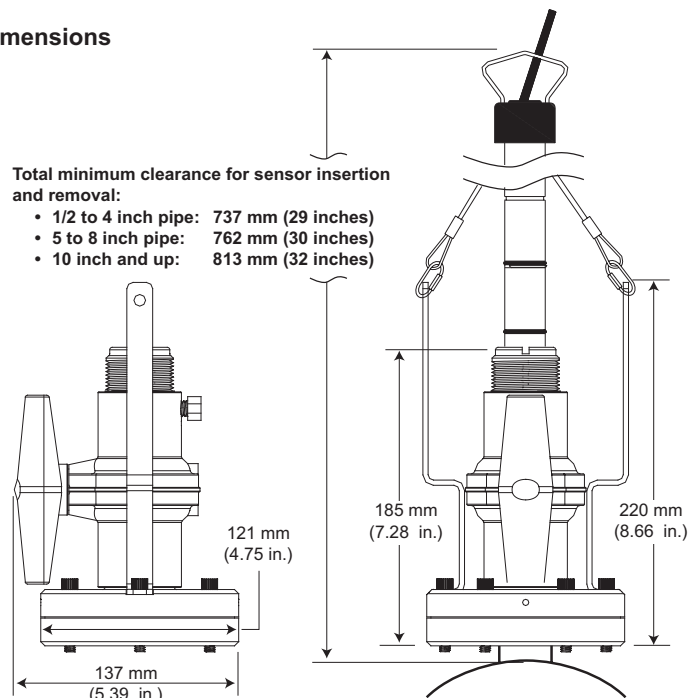

3. Flow Sensor Insertion/Removal

To insert the flow sensor:

1. Lubricate the sensor O-rings with a lubricant compatible with your process and the sensor materials of construction. Do not use petroleum based lubricants that will attack the o-rings.
2. Carefully insert the sensor into the FP-319 valve assembly until the first two O-rings seat inside the bore. (Figure 1)
 - **Do not damage the rotor on closed ball valve.**
3. Using the clamps, attach the sensor safety cable to the FP-319 assembly brackets (hand tighten only).
4. Pull the flow sensor upward to remove slack in the safety cables. (Figure 2)

 **Warning:** Safety cables are factory installed at precise length. DO NOT attempt to service or replace safety cables.

 **Warning:** System pressure must be 25 psi or less prior to sensor insertion or removal. 

5. Open the ball valve. (Figure 2).
6. Push the flow sensor into the FP-319 assembly with a twisting motion.
 - Turn the sensor so the arrows on the black conduit cap point in the direction of flow.
 - When properly aligned the sensor bale will be parallel with the pipe. (Figure 3)

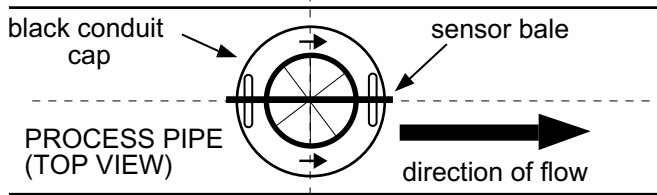

Figure 3

7. Align the tabs under the sensor cap with the notches on the fitting insert and tighten the sensor cap. (Figure 4)
 - **HAND TIGHTEN ONLY.** DO NOT use any tools that may damage plastic parts.

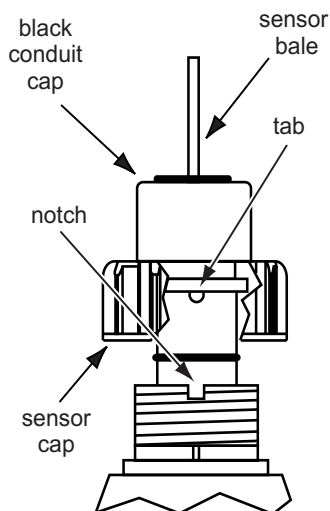

Figure 4

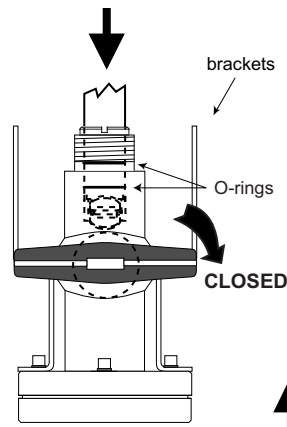

Figure 1

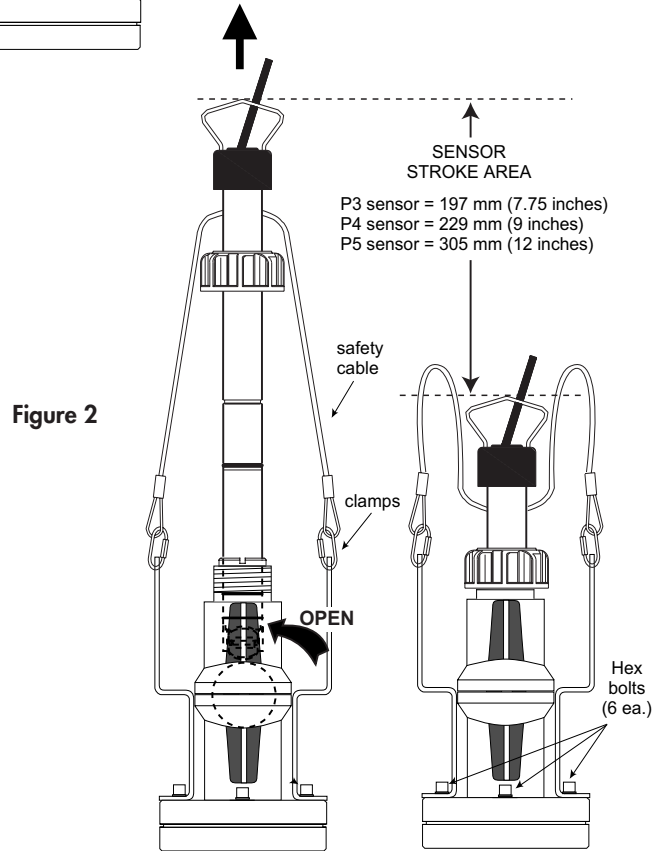





Figure 2







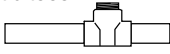

To remove the flow sensor:

 **Warning:** System pressure must be 25 psi or less prior to flow sensor insertion or removal. Stay clear of sensor stroke area and safety cable during sensor removal. 

 Check the six (6) Hex bolts (Figure 2) prior to unscrewing the sensor cap. If bolts are loose, tighten securely before proceeding.

1. Unscrew the sensor cap. (DO NOT use any tools that may damage plastic parts.)
2. Carefully pull the flow sensor upward with a twisting motion until the safety lanyards are fully extended. (Figure 2)
3. Close the ball valve. (Figure 1)
4. Loosen the relief plug to depressurize the sensor area.
5. Disconnect the sensor safety cable clamps from the FP-319 assembly brackets.
6. The sensor can now be safely removed.

4. OMEGA Fittings

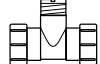
Type	Description	Type	Description
Plastic tees 	<ul style="list-style-type: none"> 0.5 to 4 inch versions PVC or CPVC 	Carbon steel & stainless steel threaded tees 	<ul style="list-style-type: none"> 0.5 to 2 inch versions
PVC Glue-on Saddles 	<ul style="list-style-type: none"> Available in 10 and 12 inch sizes only Cut 2-1/2 inch hole in pipe Weld in place using solvent cement 	Carbon steel & stainless steel Weld-on Weldolets 	<ul style="list-style-type: none"> 2 to 4 inch, cut 1-7/16 inch hole in pipe Over 4 inch, cut 2-1/4 inch hole in pipe See section 5 below for details
PVC Saddles 	<ul style="list-style-type: none"> 2 to 4 inch, cut 1-7/16 inch hole in pipe 6 to 8 inch, cut 2-1/4 inch hole in pipe 	Metric PVC-U Saddle 	<ul style="list-style-type: none"> For pipes DN 65 to 200 mm Requires a 30 mm diam. hole in the pipe
PP Clamp-on Saddles 	<ul style="list-style-type: none"> Available in 10 and 12 inch sizes only Cut 2-1/4 inch hole in pipe 	Metric Wafer Fitting 	<ul style="list-style-type: none"> For pipes DN 65 to 200 mm PP or PVDF
Iron Strap-on saddles 	<ul style="list-style-type: none"> 2 to 4 inch, cut 1-7/16 inch hole in pipe Over 4 inch, cut 2-1/4 inch hole in pipe Special order over 12 inch 	Metric Union Fitting 	<ul style="list-style-type: none"> For pipes from DN 15 to 50 mm PP or PVDF

Consult the K-factor section of the OMEGA flow sensor instruction manual for a complete listing of installation fittings.

5. H-Dimensions

The plastic sensor insert in the Weldolet or Brazolet fitting MUST be removed before the welding process. When reinstalled, it is important that the insert be threaded to the proper height ("H" dimension).

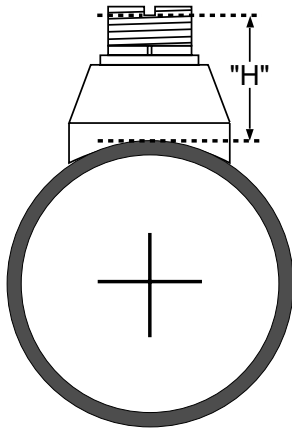

Part Number Carbon Steel	"H" dimensions		Part Number		"H" dimension	
	inches	mm	Stainless Steel	Copper/ Bronze	inches	mm
FP-5325CS	2.33	59.18	FMG-5325	FP-5325BR	2.33	59.18
FP-5330CS	2.32	58.92	FMG-5330	FP-5330BR	2.32	58.92
FP-5340CS	2.30	58.42	FMG-5340	FP-5340BR	2.30	58.42
FP-5350CS	3.09	78.48	FMG-5350	FP-5350BR	3.09	78.48
FP-5360CS	2.96	75.18	FMG-5360	FP-5360BR	2.96	75.18
FP-5380CS	2.73	69.34	FMG-5380	FP-5380BR	2.73	69.34
FP-5381CS	5.48	139.19	FMG-5381	FP-5381BR	5.48	139.19
FP-5382CS	5.25	133.35	FMG-5382	FP-5382BR	5.25	133.35

6. Ordering information

Part Number	Description
FP-319	PVC wet-tap valve (sensor not included)
FMK-515-3P3	Polypro extended length paddlewheel sensor (0.5 to 4 in.)
FMK-515-3P4	Polypro extended length paddlewheel sensor (5 to 8 in.)
FMK-515-3P5	Polypro extended length paddlewheel sensor (10 to 36 in.)
FMK-2536-3P3	Polypro extended length low flow paddlewheel sensor (0.5 to 4 in.)
FMK-2536-3P4	Polypro extended length low flow paddlewheel sensor (5 to 8 in.)
FMK-2536-3P5	Polypro extended length low flow paddlewheel sensor (10 to 36 in.)
FP-3193	Wet-tap assembly with FMK-515-3P3 paddlewheel sensor (0.5 to 4 in.)
FP-3194	Wet-tap assembly with FMK-515-3P4 paddlewheel sensor (5 to 8 in.)
FP-3195	Wet-tap assembly with FMK-515-3P5 paddlewheel sensor (10 to 36 in.)
FP-3196	Wet-tap assembly with FMK-2536-3P3 low flow sensor (0.5 to 4 in.)
FP-3197	Wet-tap assembly with FMK-2536-3P4 low flow sensor (5 to 8 in.)
FP-3198	Wet-tap assembly with FMK-2536-3P5 low flow sensor (10 to 36 in.)



WARRANTY/DISCLAIMER

OMEGA ENGINEERING, INC. warrants this unit to be free of defects in materials and workmanship for a period of **13 months** from date of purchase. OMEGA's WARRANTY adds an additional one (1) month grace period to the normal **one (1) year product warranty** to cover handling and shipping time. This ensures that OMEGA's customers receive maximum coverage on each product.

If the unit malfunctions, it must be returned to the factory for evaluation. OMEGA's Customer Service Department will issue an Authorized Return (AR) number immediately upon phone or written request. Upon examination by OMEGA, if the unit is found to be defective, it will be repaired or replaced at no charge. OMEGA's WARRANTY does not apply to defects resulting from any action of the purchaser, including but not limited to mishandling, improper interfacing, operation outside of design limits, improper repair, or unauthorized modification. This WARRANTY is VOID if the unit shows evidence of having been tampered with or shows evidence of having been damaged as a result of excessive corrosion; or current, heat, moisture or vibration; improper specification; misapplication; misuse or other operating conditions outside of OMEGA's control. Components which wear are not warranted, including but not limited to contact points, fuses, and triacs.

OMEGA is pleased to offer suggestions on the use of its various products. However, OMEGA neither assumes responsibility for any omissions or errors nor assumes liability for any damages that result from the use of its products in accordance with information provided by OMEGA, either verbal or written. OMEGA warrants only that the parts manufactured by it will be as specified and free of defects. OMEGA MAKES NO OTHER WARRANTIES OR REPRESENTATIONS OF ANY KIND WHATSOEVER, EXPRESS OR IMPLIED, EXCEPT THAT OF TITLE, AND ALL IMPLIED WARRANTIES INCLUDING ANY WARRANTY OF MERCHANTABILITY AND FITNESS FOR A PARTICULAR PURPOSE ARE HEREBY DISCLAIMED. LIMITATION OF LIABILITY: The remedies of purchaser set forth herein are exclusive, and the total liability of OMEGA with respect to this order, whether based on contract, warranty, negligence, indemnification, strict liability or otherwise, shall not exceed the purchase price of the component upon which liability is based. In no event shall OMEGA be liable for consequential, incidental or special damages.

CONDITIONS: Equipment sold by OMEGA is not intended to be used, nor shall it be used: (1) as a "Basic Component" under 10 CFR 21 (NRC), used in or with any nuclear installation or activity; or (2) in medical applications or used on humans. Should any Product(s) be used in or with any nuclear installation or activity, medical application, used on humans, or misused in any way, OMEGA assumes no responsibility as set forth in our basic WARRANTY / DISCLAIMER language, and, additionally, purchaser will indemnify OMEGA and hold OMEGA harmless from any liability or damage whatsoever arising out of the use of the Product(s) in such a manner.

RETURN REQUESTS/INQUIRIES

Direct all warranty and repair requests/inquiries to the OMEGA Customer Service Department. BEFORE RETURNING ANY PRODUCT(S) TO OMEGA, PURCHASER MUST OBTAIN AN AUTHORIZED RETURN (AR) NUMBER FROM OMEGA'S CUSTOMER SERVICE DEPARTMENT (IN ORDER TO AVOID PROCESSING DELAYS). The assigned AR number should then be marked on the outside of the return package and on any correspondence.

The purchaser is responsible for shipping charges, freight, insurance and proper packaging to prevent breakage in transit.

FOR **WARRANTY** RETURNS, please have the following information available BEFORE contacting OMEGA:

1. Purchase Order number under which the product was PURCHASED,
2. Model and serial number of the product under warranty, and
3. Repair instructions and/or specific problems relative to the product.

FOR **NON-WARRANTY** REPAIRS, consult OMEGA for current repair charges. Have the following information available BEFORE contacting OMEGA:

1. Purchase Order number to cover the COST of the repair,
2. Model and serial number of the product, and
3. Repair instructions and/or specific problems relative to the product.

OMEGA's policy is to make running changes, not model changes, whenever an improvement is possible. This affords our customers the latest in technology and engineering.

OMEGA is a registered trademark of OMEGA ENGINEERING, INC.

© Copyright 2000 OMEGA ENGINEERING, INC. All rights reserved. This document may not be copied, photocopied, reproduced, translated, or reduced to any electronic medium or machine-readable form, in whole or in part, without the prior written consent of OMEGA ENGINEERING, INC.

Where Do I Find Everything I Need for Process Measurement and Control? OMEGA...Of Course!

Shop online at www.omega.com

TEMPERATURE

- ☑ Thermocouple, RTD & Thermistor Probes, Connectors, Panels & Assemblies
- ☑ Wire: Thermocouple, RTD & Thermistor
- ☑ Calibrators & Ice Point References
- ☑ Recorders, Controllers & Process Monitors
- ☑ Infrared Pyrometers

PRESSURE, STRAIN AND FORCE

- ☑ Transducers & Strain Gages
- ☑ Load Cells & Pressure Gages
- ☑ Displacement Transducers
- ☑ Instrumentation & Accessories

FLOW/LEVEL

- ☑ Rotameters, Gas Mass Flowmeters & Flow Computers
- ☑ Air Velocity Indicators
- ☑ Turbine/Paddlewheel Systems
- ☑ Totalizers & Batch Controllers

pH/CONDUCTIVITY

- ☑ pH Electrodes, Testers & Accessories
- ☑ Benchtop/Laboratory Meters
- ☑ Controllers, Calibrators, Simulators & Pumps
- ☑ Industrial pH & Conductivity Equipment

DATA ACQUISITION

- ☑ Data Acquisition & Engineering Software
- ☑ Communications-Based Acquisition Systems
- ☑ Plug-in Cards for Apple, IBM & Compatibles
- ☑ Datalogging Systems
- ☑ Recorders, Printers & Plotters

HEATERS

- ☑ Heating Cable
- ☑ Cartridge & Strip Heaters
- ☑ Immersion & Band Heaters
- ☑ Flexible Heaters
- ☑ Laboratory Heaters

ENVIRONMENTAL MONITORING AND CONTROL

- ☑ Metering & Control Instrumentation
- ☑ Refractometers
- ☑ Pumps & Tubing
- ☑ Air, Soil & Water Monitors
- ☑ Industrial Water & Wastewater Treatment
- ☑ pH, Conductivity & Dissolved Oxygen Instruments