

# User's Guide



*Shop online at*

**omega.com<sup>®</sup>**

Ω OMEGA<sup>®</sup>

*omega.com*

*e-mail: info@omega.com*

*For latest product manuals:  
omegamanual.info*

**ISO 9001**  
CERTIFIED  
CORPORATE QUALITY  
STAMFORD, CT

**ISO 9002**  
CERTIFIED  
CORPORATE QUALITY  
MANCHESTER, UK

## IP710 SERIES I/P Converters



**OMEGAnet® Online Service**  
**www.omega.com**

**Internet e-mail**  
**info@omega.com**

### **Servicing North America:**

**USA:**  
ISO 9001 Certified

One Omega Drive, P.O. Box 4047  
Stamford CT 06907-0047  
TEL: (203) 359-1660 FAX: (203) 359-7700  
e-mail: info@omega.com

**Canada:**

976 Bergar  
Laval (Quebec) H7L 5A1, Canada  
TEL: (514) 856-6928 FAX: (514) 856-6886  
e-mail: info@omega.ca

### **For immediate technical or application assistance:**

**USA and Canada:** Sales Service: 1-800-826-6342 / 1-800-TC-OMEGA®  
Customer Service: 1-800-622-2378 / 1-800-622-BEST®  
Engineering Service: 1-800-872-9436 / 1-800-USA-WHEN®  
TELEX: 996404 EASYLINK: 62968934 CABLE: OMEGA

**Mexico:**

En Español: (001) 203-359-7803 e-mail: espanol@omega.com  
FAX: (001) 203-359-7807 info@omega.com.mx

### **Servicing Europe:**

**Benelux:**

Postbus 8034, 1180 LA Amstelveen, The Netherlands  
TEL: +31 (0)20 3472121 FAX: +31 (0)20 6434643  
Toll Free in Benelux: 0800 0993344  
e-mail: sales@omegaeng.nl

**Czech Republic:**

Frystatska 184, 733 01 Karviná, Czech Republic  
TEL: +420 (0)59 6311899 FAX: +420 (0)59 6311114  
Toll Free: 0800-1-66342 e-mail: info@omegashop.cz

**France:**

11, rue Jacques Cartier, 78280 Guyancourt, France  
TEL: +33 (0)1 61 37 29 00 FAX: +33 (0)1 30 57 54 27  
Toll Free in France: 0800 466 342  
e-mail: sales@omega.fr

**Germany/Austria:**

Daimlerstrasse 26, D-75392 Deckenpfronn, Germany  
TEL: +49 (0)7056 9398-0 FAX: +49 (0)7056 9398-29  
Toll Free in Germany: 0800 639 7678  
e-mail: info@omega.de

**United Kingdom:**  
ISO 9002 Certified

One Omega Drive, River Bend Technology Centre  
Northbank, Irlam, Manchester  
M44 5BD United Kingdom  
TEL: +44 (0)161 777 6611 FAX: +44 (0)161 777 6622  
Toll Free in United Kingdom: 0800-488-488  
e-mail: sales@omega.co.uk

It is the policy of OMEGA to comply with all worldwide safety and EMC/EMI regulations that apply. OMEGA is constantly pursuing certification of its products to the European New Approach Directives. OMEGA will add the CE mark to every appropriate device upon certification.

The information contained in this document is believed to be correct, but OMEGA Engineering, Inc. accepts no liability for any errors it contains, and reserves the right to alter specifications without notice.

**WARNING:** These products are not designed for use in, and should not be used for, patient-connected applications.



## WARRANTY/DISCLAIMER

OMEGA ENGINEERING, INC. warrants this unit to be free of defects in materials and workmanship for a period of **13 months** from date of purchase. OMEGA's WARRANTY adds an additional one (1) month grace period to the normal **one (1) year product warranty** to cover handling and shipping time. This ensures that OMEGA's customers receive maximum coverage on each product.

If the unit malfunctions, it must be returned to the factory for evaluation. OMEGA's Customer Service Department will issue an Authorized Return (AR) number immediately upon phone or written request. Upon examination by OMEGA, if the unit is found to be defective, it will be repaired or replaced at no charge. OMEGA's WARRANTY does not apply to defects resulting from any action of the purchaser, including but not limited to mishandling, improper interfacing, operation outside of design limits, improper repair, or unauthorized modification. This WARRANTY is VOID if the unit shows evidence of having been tampered with or shows evidence of having been damaged as a result of excessive corrosion; or current, heat, moisture or vibration; improper specification; misapplication; misuse or other operating conditions outside of OMEGA's control. Components which wear are not warranted, including but not limited to contact points, fuses, and triacs.

**OMEGA is pleased to offer suggestions on the use of its various products. However, OMEGA neither assumes responsibility for any omissions or errors nor assumes liability for any damages that result from the use of its products in accordance with information provided by OMEGA, either verbal or written. OMEGA warrants only that the parts manufactured by it will be as specified and free of defects. OMEGA MAKES NO OTHER WARRANTIES OR REPRESENTATIONS OF ANY KIND WHATSOEVER, EXPRESS OR IMPLIED, EXCEPT THAT OF TITLE, AND ALL IMPLIED WARRANTIES INCLUDING ANY WARRANTY OF MERCHANTABILITY AND FITNESS FOR A PARTICULAR PURPOSE ARE HEREBY DISCLAIMED. LIMITATION OF LIABILITY: The remedies of purchaser set forth herein are exclusive, and the total liability of OMEGA with respect to this order, whether based on contract, warranty, negligence, indemnification, strict liability or otherwise, shall not exceed the purchase price of the component upon which liability is based. In no event shall OMEGA be liable for consequential, incidental or special damages.**

CONDITIONS: Equipment sold by OMEGA is not intended to be used, nor shall it be used: (1) as a "Basic Component" under 10 CFR 21 (NRC), used in or with any nuclear installation or activity; or (2) in medical applications or used on humans. Should any Product(s) be used in or with any nuclear installation or activity, medical application, used on humans, or misused in any way, OMEGA assumes no responsibility as set forth in our basic WARRANTY/DISCLAIMER language, and, additionally, purchaser will indemnify OMEGA and hold OMEGA harmless from any liability or damage whatsoever arising out of the use of the Product(s) in such a manner.

## RETURN REQUESTS/INQUIRIES

Direct all warranty and repair requests/inquiries to the OMEGA Customer Service Department. BEFORE RETURNING ANY PRODUCT(S) TO OMEGA, PURCHASER MUST OBTAIN AN AUTHORIZED RETURN (AR) NUMBER FROM OMEGA'S CUSTOMER SERVICE DEPARTMENT (IN ORDER TO AVOID PROCESSING DELAYS). The assigned AR number should then be marked on the outside of the return package and on any correspondence.

The purchaser is responsible for shipping charges, freight, insurance and proper packaging to prevent breakage in transit.

FOR **WARRANTY** RETURNS, please have the following information available BEFORE contacting OMEGA:

1. Purchase Order number under which the product was PURCHASED,
2. Model and serial number of the product under warranty, and
3. Repair instructions and/or specific problems relative to the product.

FOR **NON-WARRANTY** REPAIRS, consult OMEGA for current repair charges. Have the following information available BEFORE contacting OMEGA:

1. Purchase Order number to cover the COST of the repair,
2. Model and serial number of the product, and
3. Repair instructions and/or specific problems relative to the product.

OMEGA's policy is to make running changes, not model changes, whenever an improvement is possible. This affords our customers the latest in technology and engineering.

OMEGA is a registered trademark of OMEGA ENGINEERING, INC.

© Copyright 2002 OMEGA ENGINEERING, INC. All rights reserved. This document may not be copied, photocopied, reproduced, translated, or reduced to any electronic medium or machine-readable form, in whole or in part, without the prior written consent of OMEGA ENGINEERING, INC.

# IP710 SERIES I/P Converters

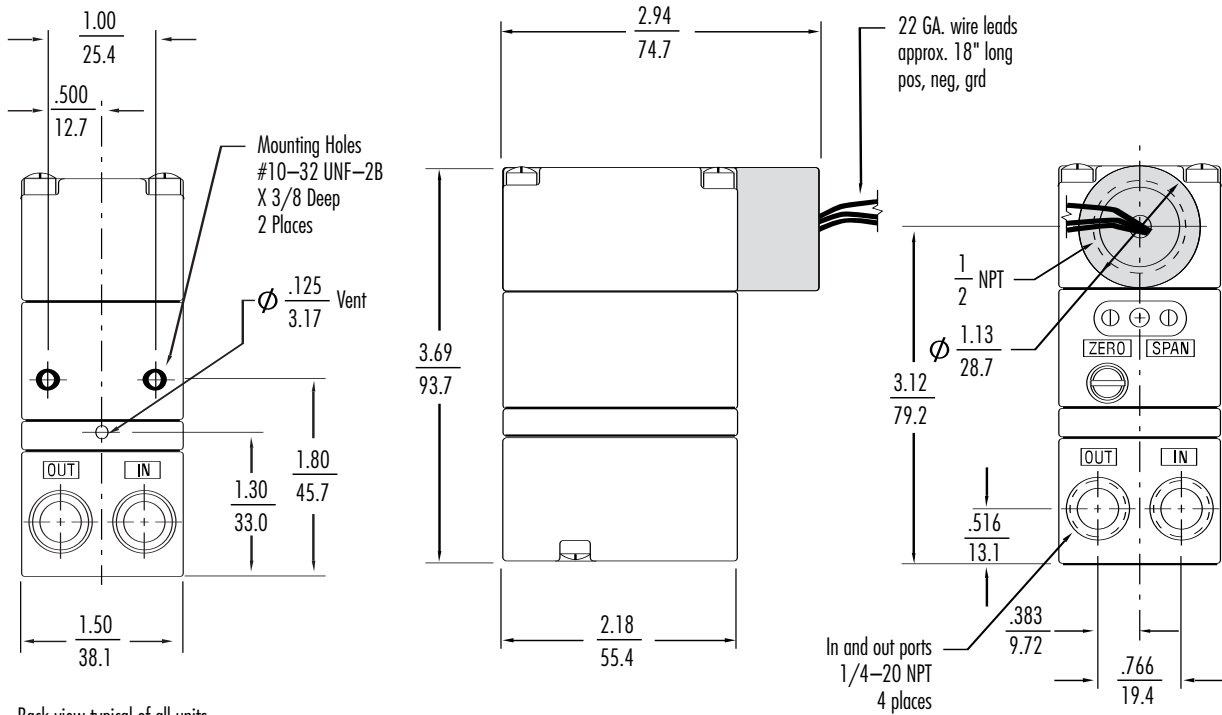

Back view typical of all units

## Contents

Section	Description	Page
1.0	Description & Installation	3
2.0	Operation	6
3.0	Maintenance & Repairs	8
4.0	Troubleshooting	8
5.0	Warning	8

## DANGER, WARNING, CAUTION and NOTE statements

**DANGER** Refers to conditions or hazards which could result in serious personal injury or death.

**WARNING** Refers to conditions or hazards which could result in personal injury.

**CAUTION** Refers to conditions or hazards which could result in equipment or property damage.

**NOTE** Alerts you to facts or special instructions.

**ALL DANGER, WARNING, AND CAUTION NOTICES MUST BE COMPLIED WITH IN FULL**

## SPECIFICATIONS

### Functional Specifications

	Standard Range				High Output Range	
Inputs	4-20 mA					
Outputs psig (BAR)	1-17 (0.07-1.2)	3-15 (0.2-1.0)	3-27 (0.2-1.8)	6-30 (0.4-2.0)	2-60 (0.14-4.0)	2-100 (0.14-6.9)
Supply Pressure psig (BAR)	22-60 (1.5-4.0)	20-100 (1.4-6.9)	32-100 (2.2-6.9)	35-100 (2.4-6.9)	65-100 (4.5-6.9)	105-130 (7.2-9.0)
Air Consumption <small>*Zero-based units have slightly higher air consumption</small>	1.5 scfh (0.04 m3/hr) at mid range typical				4.5 scfh (0.13 m3/hr) at mid range typical	
Flow Capacity	4.5 scfm (7.6 m3/hr) at 25 psig (1.7 BAR) supply				20.0 scfm (34.0 m3/hr) at 130 psig (9.0 BAR) supply	
	12.0 scfm (20.0 m3/hr) at 100 psig (7.0 BAR) supply					
Temperature Limits	Operating: -40° to +160° F (-40° to +71° C) Storage: -40° to +200° F (-40° to +93° C)					
Loop Load, I/P Transducer	9.5 VDC @ 20 mA					

### Performance Specifications

Accuracy, Hysteresis and Repeatability	±0.10% of span guaranteed
Deadband	0.02% of span
Position Effect	No measurable effect
Vibration Effect	Less than ±1.0% of span under the following conditions: 5-15Hz @ 0.8 inches constant displacement 15-500Hz @ 10g s
Supply Pressure Effect	No measurable effect
Temperature Effect	±0.045%/F (0.07%/C) of span
Reverse Polarity Effect	No damage occurs from reversal of normal supply current (4-20mA) or from misapplication of up to 60mA
RFI/EMI Effect	Pending

### Physical Specifications

Port Sizes	Pneumatic: 1/4" NPT
Media	Clean, dry, oil-free air-filtered to 40 micron
Mounting	Wall, panel, 2" pipe, or DIN rail (optional)
Materials	Housing: Chromate-treated aluminum with baked paint, NEMA 4X (IP65) Elastomers: Buna-N Trim: Stainless steel; brass; zinc-plated steel
Weight	13.0 oz. (0.4 kg)

# 1. DESCRIPTION and INSTALLATION

## 1.1 Description

- 1.1.1 The Omega IP710 converts a current input signal to a linearly proportional pneumatic output pressure. This unit utilizes a closed loop pressure feedback system that closely controls output and compensates for vibration, mounting angle, temperature and supply pressure variations. The control mechanism is a piezoceramic actuator. The unique properties of this actuator protect it against moisture and breakage associated with similar competitive technologies.

## 1.2 Principle of Operation

- 1.2.1 The IP710 transducer is a force balance device in which the piezo actuator is positioned in relation to a nozzle as the input signal is varied. The application of an electrical signal causes axial movement of the actuator. The actuator moves toward the nozzle and creates back pressure which acts as a pilot pressure to an integral booster relay.

## 1.3 Mounting

- 1.3.1 Each IP710 comes with a mounting kit which enables pipe, panel or wall mounting of the unit. An optional mounting kit is available for DIN-rail mountings. The IP710 may be mounted at any angle.
- 1.3.2 Panel: With access to rear of panel, attach transducer to panel using two 10-32 screws and the two threaded mounting holes on the back of the unit. With no access to the rear of a panel, attach bracket to transducer using two 10-32 holes on the back of the unit and mount bracket to panel using four 10-32 screws (see figure 1).

**Figure 1 - Standard Panel Mount**

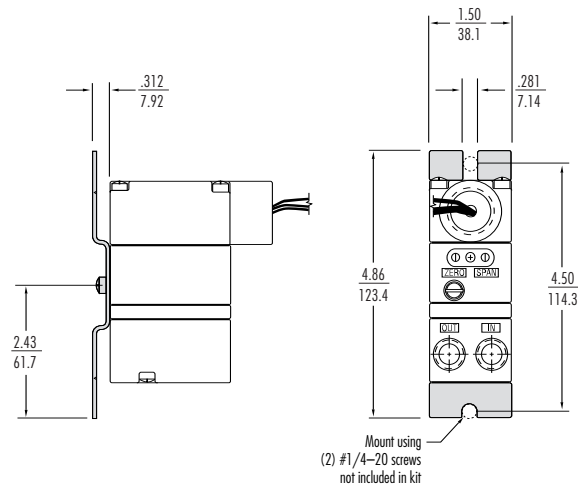

- 1.3.3 **In- Line:** Due to its light weight, the IP710 may be supported by the piping used for supply and output.
- 1.3.4 **1 1/2" Pipe:** Attach bracket to transducer using two 10-32 holes on the back of unit. Place U-bolt around pipe and through bracket. Place nuts on U-bolt and tighten (see figure 2).

**Figure 2 - Standard 1 1/2" Pipe Mount**

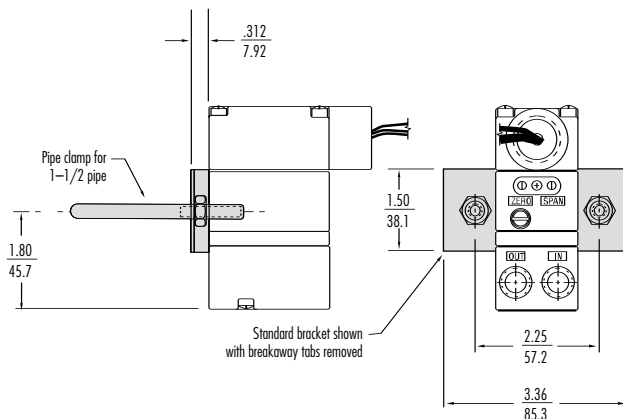

**Figure 3 - DIN 43650 Connector**

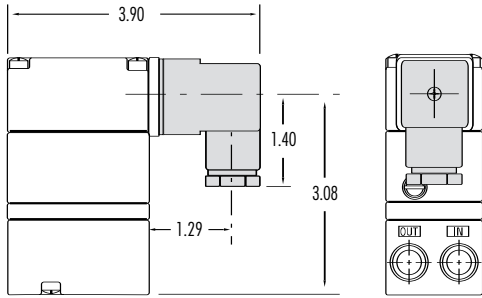

**DIN Rail mounting kit IP610-DM**

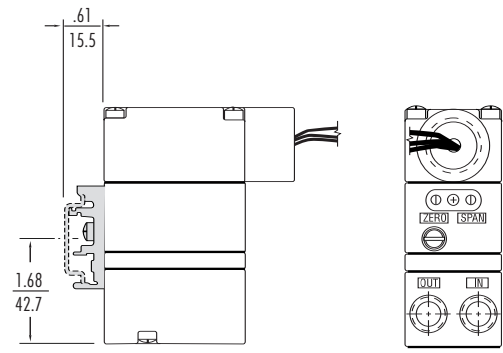

DIN Rail Kit suitable for EN-50035, EN-50045 and EN-50022 Rails

## 1.4 Pneumatic Connections

- 1.4.1 Clean all pipe lines to remove dirt and scale before installation.
- 1.4.2 Supply air must be filtered to 40 microns and free of moisture and lubricants.
- 1.4.3 The 1/4" NPT inlet and outlet connections are labeled on the body. Plug all unused ports with pipe plugs supplied with the unit. Avoid getting pipe sealant inside the piping or transducer.

**WARNING** The I/P transducer enclosure contains aluminum and is considered to constitute a potential risk of ignition by impact or friction and must be taken into account during installation.

## 1.5 Electrical Connections

- 1.5.1 **Conduit Connection (current to pressure)** Electrical connections are made to the red (+) and black (-) leads. The green lead is furnished for case ground (see figure 4).

**Figure 4**

**I/P Conduit Connection**

**Figure 5 - DIN 43650 Connector**

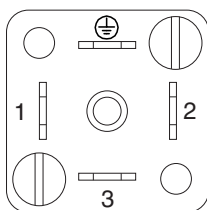

Terminal	I/P Connection
1	Positive (+)
2	Negative (-)
3	Unused
⊕	Ground (+)

**Figure 6 - I/P Conduit Connection**

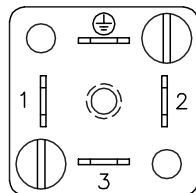

# 1.6 Factory Mutual Research Corporation (FM) and Canadian Standards association (CSA)

## Intrinsically Safe

Class I, II, III, Div. 1,  
Groups C, D, E, F & G  
Models IP710-\*

Class I, Div. 1, Groups C & D  
Models IP710-\*

## Suitable for:

Class I, Div. 2, Groups A, B, C & D  
Models IP710-\*,  
IP710-\*

## Suitable for:

Class II & III, Div. 2, Groups F & G  
Models IP710-\*

\*= Output pressure option does not affect rating

## Factory Mutual and Canadian Standards Association I.S. Installation Drawing

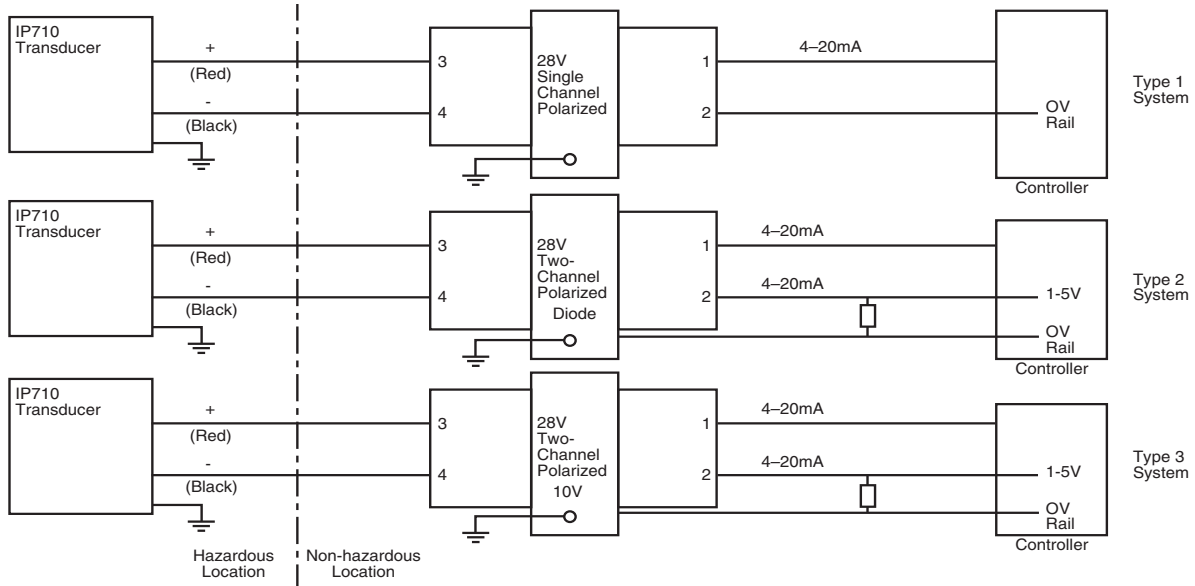

### Notes:

- Control equipment connected to the Associated Apparatus must not use or generate more than 250 Vrms or Vdc.
- The IS Barriers or Equipment (Associated Apparatus) must be FM Approved and CSA Certified and the configuration of Associated Apparatus must be FM Approved and CSA Certified under the Entity Concept. The Associated Apparatus may be installed within the Hazardous (Classified) location for which it is certified. The Associated Apparatus and hazardous location loop apparatus manufacturer's control drawings must be followed when installing this equipment. An AEx [ib] Associated Apparatus is suitable only for connection to Class I, Zone 1, Hazardous (Classified) Locations and is not suitable for Class I, Zone 0, or Class I, Division 1 Hazardous (Classified) Locations.
- Installation should be in accordance with ANSI/ISA RP12.6 "Installation of Intrinsically Safe Systems for Hazardous (Classified) Locations" and Article 500 of the National Electrical Code (ANSI/NFPA 70).
- The standard conduit is suitable for Type 4X installations. All others must be mounted in a suitable enclosure.
- The standard conduit is suitable for Class I, II and III, Division 2, Groups A, B, C, D, F & G hazardous (classified) locations. Dust-tight conduit seal must be used when installed in Class II and Class III environments.  
The connection option "D" is suitable for Class I, Division 2, Groups A, B, C and D hazardous (classified) locations.  
Transducers to be installed in accordance with National Electrical Code (ANSI/NFPA 70) Division 2 hazardous (classified) location wiring techniques.
- The Intrinsic Safety Entity concept allows the interconnection of two FM Approved or CSA Certified intrinsically safe devices with entity parameters not specifically examined in combination as a system when:

$U_i$  or  $V_{max} > U_o$  or  $V_{oc}$  or  $V_t > 7.2$  volts  
 $I_i$  or  $I_{max} > I_o$  or  $I_{sc}$  or  $I_t$   
 $C_a$  or  $C_o > C_i + C_{cable}$   
 $L_a$  or  $L_o > L_i + L_{cable}$   
 $P_i > P_o$

### Entity Parameters for Models IP710-\*

$U_i$  ( $V_{max}$ ) = 30 V  
 $I_i$  ( $I_{max}$ ) = 125 mA  
 $P_i$  = 0.70 watts  
 $C_i$  = 0 uF  
 $L_i$  = 0 mH

- No revision to this drawing is permitted without prior Factory Mutual Research Approval.

## 2. OPERATION

### 2.1 Calibration

- 2.1.1 All units are shipped from the factory calibrated, direct acting.
- 2.1.2 If the user requires a different mode of operation (i.e. reverse acting, split range) it is necessary to reposition internal electrical switches as indicated below. Though the units are factory calibrated for direct acting it is suggested that the user check the calibration.
- 2.1.3 It is not necessary to remove the cover of the unit for calibration if the direct acting mode is desired.

### 2.2 Direct Acting Calibration

- 2.2.1 In direct acting operation the unit is calibrated so that minimum input signal corresponds to minimum output pressure and increasing input signal results in increasing output pressure.
- 2.2.2 Apply the minimum input signal of the range being used (e.g. 4mA for a 4-20mA unit) (see figure 6).
- 2.2.3 Observe the output pressure. If necessary, adjust the zero screw until reaching minimum output pressure setting. Turn zero screw clockwise to decrease and counter clockwise to increase.
- 2.2.4 Apply the maximum input signal of the range being used (e.g. 20mA for a 4-20mA unit).
- 2.2.5 Observe the output pressure. If necessary, adjust the span screw until reaching maximum output pressure setting. Turn span screw clockwise to decrease and counter clockwise to increase.
- 2.2.6 After setting the span it will be necessary to recheck the zero. Repeat steps 1-4 until both end points are at required values.

**Figure 6 - Zero Adjustment and Span Adjustment**

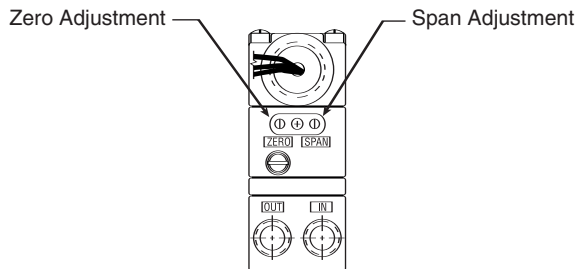

**Figure 7 - Direct Acting - Position of switches for forward acting operation (all output ranges).**

Standard setting as supplied by factory.

Signal	SWITCH	1	2	3	4	5	6	7	8	9	10	11	12
4-20 mA	ON			■		■		■		■		■	■
	OFF	■	■		■		■		■		■		■

## 2.3 Reverse Acting Calibration

- 2.3.1 When calibrated to operate in the reverse acting mode the minimum input signal produces the maximum output pressure and increasing the input signal results in decreasing the output pressure. Setting the unit to operate in the reverse acting mode is accomplished by positioning internal electrical switches.

**CAUTION** Do not reverse the input leads.

- 2.3.2 Disconnect input signal and supply pressure. Take off the top cover by removing the four screws.

**CAUTION** Avoid touching circuit board. Shorting possible.

- 2.3.3 Position switches as illustrated in figure 8. Replace cover.  
2.3.4 Set the input signal to the minimum valve being used. Turn the zero screw to set the maximum output pressure.  
2.3.5 Set the span by applying the maximum input signal. Turn the span screw to set the minimum output pressure.  
2.3.6 It may be necessary to repeat steps 2.3.4 – 2.3.5 until both end points are at desired values.

**Figure 8 - Position of switches for Reverse Acting Operation**

SWITCH	3	4	5	6	7	10
ON		■		■		■
OFF	■		■		■	

Note: Switches not shown match Direct Acting Settings (see figure 7).

## 2.4 Split Range

- 2.4.1 When calibrated to operate in the split range mode, a full input signal (i.e. 4-20mA) will operate the unit at one half the normal output span (i.e. 3-9 psig, 9-15 psig). Setting the unit to operate in the split range mode is accomplished by positioning internal electrical switches.  
2.4.2 Disconnect input signal and supply pressure. Take off the top cover of the unit by removing the four screws.

**CAUTION** Avoid touching circuit board. Shorting possible.

- 2.4.3 Position switches as illustrated in figure 9. Replace cover  
2.4.4 After setting switches, refer to the appropriate calibration procedure (Direct Acting or Reverse Acting) to get to desired output range (i.e. 3-9 psig, 9-15 psig).

**Figure 9 - Position of switches for Split Range Operation**

SWITCH	1	2
ON	■	■
OFF		

4-20 mA

Note: Switches not shown match Direct Acting Settings (see figure 7).

## 3. MAINTENANCE AND REPAIRS

**NOTE** Under normal circumstances, no maintenance should be required.

### 3.1 Cleaning

- 3.1.1 If clean, dry air is not used the orifice can become blocked. To clear, first turn off supply air, then remove the screw located under the zero adjustment. The orifice is located between the two black o-rings. You may need a magnifying glass to see it. Unplug the orifice by running a wire that has a smaller diameter than 0.012" (0.30mm) through it.
- 3.1.2 Used compressed air to blow out any loose particles inside the orifice screw assembly.

### 3.2 Precautions

- 3.2.1 The bonnet should be removed only if a different operation mode is desired which requires a change in circuit board switch settings. In this case, precautions are necessary.
- 3.2.2 Never handle circuit board unless properly grounded to prevent ESD (Electro-static Discharge).
- 3.2.3 If ESD grounding equipment is not available, hold the IP710 by its castings and adjust switches using a non-conductive device such as a pencil or a small rubber handled screwdriver.
- 3.2.4 Never remove circuit board for any reason. This will shift other components and possibly damage the pressure sensor, both cases resulting in malfunction.
- 3.2.5 Use caution when replacing bonnet. If any resistance is felt, remove bonnet and determine the interference. Typically it will be the strain relief grommet on the wires. The grommet should be oriented so it sits beside the switches.
- 3.2.6 Clean, dry air should be used with the IP710. Foreign matter in the supply line can clog the orifice openings. (.013" for a 3-15 psig unit, smaller for higher range units.) Foreign matter can also collect on the actuator causing erratic operation. Moisture in the supply line can damage circuit board components.
- 3.2.7 The electrical specifications as outlined in the IP710 instructions must be complied with. If more than one IP710 mA unit is driven by the same PLC, there must be a minimum of 9.5 v DC available to each unit. For a IP710 voltage unit, there must be a constant supply voltage of 7-30 v DC applied to the red wire. The variable control voltage is applied to the orange wire.
- 3.2.8 If difficulty is experienced during calibration or if turning the zero or span screw has no effect on the unit, a resetting technique can be taken. Turn both the zero and span screw a minimum of 30 revolutions in one direction. Then turn both screws exactly 15 revolutions in the opposite direction. This procedure will put the potentiometers at their midpoint of effective adjustability. Next, calibrate to desired settings starting with the zero screw.
- 3.2.9 Reverse Acting Mode: For reverse acting units, the zero adjustment refers to the minimum electrical signal and maximum output pressure. The span refers to the maximum signal and the minimum output pressure. For calibration in reverse mode the resetting technique can be taken if necessary and calibration should always begin with the zero screw.

## 4. TROUBLESHOOTING

PROBLEM	CHECK	SOLUTION
Sluggish performance or reduced range	Blocked orifice Supply pressure	Clean orifice (3.1) Increase supply pressure (see specs)
Leakage	Connections	Check seal at port
Low or improper span	Supply pressure Connections	Increase supply pressure (see specs) Check seal at port
Erratic operation	Moisture in air supply Loose wires or connections Dip switch settings	Use clean, dry air (see specs) Check wiring (1.5) Reset dip switches (2.2/2.3/2.4)

## 5. WARNING

**FAILURE MODES:** This device must not be used for protecting final control elements connected to the output port from the effect of pressure present at the supply port. If devices connected to the output port have a pressure rating less than the pressure present at the supply port, then pressure relieving or pressure limiting devices must be employed to protect the devices from over pressurization, possibly causing physical damage, personal injury and/or property damage.

# Where Do I Find Everything I Need for Process Measurement and Control? **OMEGA...Of Course!**

*Shop online at [www.omega.com](http://www.omega.com)*

## **TEMPERATURE**

- Thermocouple, RTD & Thermistor Probes, Connectors, Panels & Assemblies
- Wire: Thermocouple, RTD & Thermistor
- Calibrators & Ice Point References
- Recorders, Controllers & Process Monitors
- Infrared Pyrometers

## **PRESSURE, STRAIN AND FORCE**

- Transducers & Strain Gages
- Load Cells & Pressure Gages
- Displacement Transducers
- Instrumentation & Accessories

## **FLOW/LEVEL**

- Rotameters, Gas Mass Flowmeters & Flow Computers
- Air Velocity Indicators
- Turbine/Paddlewheel Systems
- Totalizers & Batch Controllers

## **pH/CONDUCTIVITY**

- pH Electrodes, Testers & Accessories
- Benchtop/Laboratory Meters
- Controllers, Calibrators, Simulators & Pumps
- Industrial pH & Conductivity Equipment

## **DATA ACQUISITION**

- Data Acquisition & Engineering Software
- Communications-Based Acquisition Systems
- Plug-in Cards for Apple, IBM & Compatibles
- Datalogging Systems
- Recorders, Printers & Plotters

## **HEATERS**

- Heating Cable
- Cartridge & Strip Heaters
- Immersion & Band Heaters
- Flexible Heaters
- Laboratory Heaters

## **ENVIRONMENTAL MONITORING AND CONTROL**

- Metering & Control Instrumentation
- Refractometers
- Pumps & Tubing
- Air, Soil & Water Monitors
- Industrial Water & Wastewater Treatment
- pH, Conductivity & Dissolved Oxygen Instruments