

5

To Configure Meter Inputs:

1. Press MENU until the meter displays:
2. Press ►/MIN to display:
3. Press ▲/MAX, if necessary to change the configuration value.
4. Repeat steps 2 and 3 for INP2 through INP.7
5. Press MENU
The meter displays:

To Set Decimal Point Position:

1. Press MENU until the meter displays:
 2. Press ►/MIN to display:
Press ▲/MAX to move the decimal point to the desired location.
 3. Press MENU.
The meter displays:
 4. Press RESET twice. The meter flashes and displays an output reading.
- The meter is now in RUN mode.

Configure Reading Offset

Now that you are in the run mode with a transducer connected to the meter, do the following:

1. Simulate a load on the transducer (leave the pressure port open).
2. Note the display reading. Let's assume the display shows 43.5
3. To make the display show zeroes, press MENU until the meter displays:
4. Press ►/MIN to display the previous reading offset value.
5. Using ►/MIN to scroll through the digits and ▲/MAX to change the value, enter the value -0043.5

6

Configure Reading Offset (continued)

6. Press MENU.
The meter displays:
7. Press RESET twice.
The meter flashes and then displays a value.

Your meter is now in RUN mode and operational.

If You Have Bipolar Input ±50mV

The typical setting for your meter is unipolar. If, however, you have bipolar input ±50mV, you must install jumper S1B. Remove the outer panel mounting sleeve to expose the jumper.

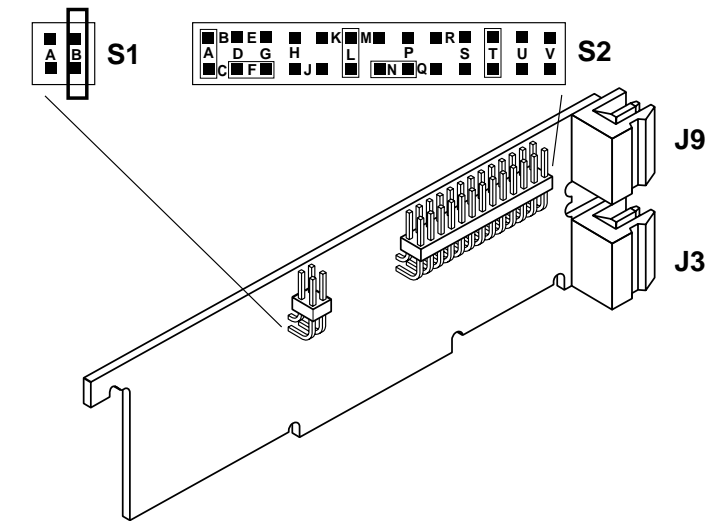

S1 Jumper Location on Signal Input Board

In addition, you must set configuration menu value INP.3=1 (under IN CNF menu). Refer to the Configuration sections of this Quick Start manual.

MADE IN USA **WARRANTY/DISCLAIMER**

OMEGA ENGINEERING, INC. warrants this unit to be free of defects in materials and workmanship for a period of **one (1) year** from the date of purchase. In addition to OMEGA's standard warranty period, OMEGA Engineering will extend the warranty period for **four (4) additional years** if the warranty card enclosed with each instrument is returned to OMEGA.

If the unit malfunctions, it must be returned to the factory for evaluation. OMEGA's Customer Service Department will issue an Authorized Return (AR) number immediately upon phone or written request. Upon examination by OMEGA, if the unit is found to be defective, it will be repaired or replaced at no charge. OMEGA's WARRANTY does not apply to defects resulting from any action of the purchaser, including but not limited to mishandling, improper interfacing, operation outside of design limits, improper repair, or unauthorized modification. This WARRANTY is VOID if the unit shows evidence of having been tampered with or shows evidence of having been damaged as a result of excessive corrosion, or current, heat, moisture or vibration; improper specification; misapplication; misuse or other operating conditions outside of OMEGA's control. Components which wear are not warranted, including but not limited to contact points, fuses, and triacs.

OMEGA is pleased to offer suggestions on the use of its various products. However, OMEGA neither assumes responsibility for any omissions or errors nor assumes liability for any damages that result from the use of its products in accordance with information provided by OMEGA, either verbal or written. OMEGA warrants only that the parts manufactured by it will be as specified and free of defects. OMEGA MAKES NO OTHER WARRANTIES OR REPRESENTATIONS OF ANY KIND WHATSOEVER, EXPRESS OR IMPLIED, EXCEPT THAT OF TITLE, AND ALL IMPLIED WARRANTIES INCLUDING ANY WARRANTY OF MERCHANTABILITY AND FITNESS FOR A PARTICULAR PURPOSE ARE HEREBY DISCLAIMED. LIMITATION OF LIABILITY: The remedies of purchaser set forth herein are exclusive, and the total liability of OMEGA with respect to this order, whether based on contract, warranty, negligence, indemnification, strict liability or otherwise, shall not exceed the purchase price of the component upon which liability is based. In no event shall OMEGA be liable for consequential, incidental or special damages.

CONDITIONS: Equipment sold by OMEGA is not intended to be used, nor shall it be used: (1) as a "Basic Component" under 10 CFR 21 (NRC), used in or with any nuclear installation or activity; or (2) in medical applications or used on humans. Should any Product(s) be used in or with any nuclear installation or activity, medical application, used on humans, or misused in any way, OMEGA assumes no responsibility as set forth in our basic WARRANTY/DISCLAIMER language, and, additionally, purchaser will indemnify OMEGA and hold OMEGA harmless from any liability or damage whatsoever arising out of the use of the Product(s) in such a manner.

RETURN REQUESTS/INQUIRIES

Direct all warranty and repair requests/inquiries to the OMEGA Customer Service Department. BEFORE RETURNING ANY PRODUCT(S) TO OMEGA, PURCHASER MUST OBTAIN AN AUTHORIZED RETURN (AR) NUMBER FROM OMEGA'S CUSTOMER SERVICE DEPARTMENT (IN ORDER TO AVOID PROCESSING DELAYS). The assigned AR number should then be marked on the outside of the return package and on any correspondence.

The purchaser is responsible for shipping charges, freight, insurance and proper packaging to prevent breakage in transit.

FOR WARRANTY RETURNS, please have the following information available BEFORE contacting OMEGA:

1. Purchase Order number under which the product was PURCHASED,
2. Model and serial number of the product under warranty, and
3. Repair instructions and/or specific problems relative to the product.

FOR NON-WARRANTY REPAIRS, consult OMEGA for current repair charges. Have the following information available BEFORE contacting OMEGA:

1. Purchase Order number to cover the COST of the repair,
2. Model and serial number of product, and
3. Repair instructions and/or specific problems relative to the product.

OMEGA's policy is to make running changes, not model changes, whenever an improvement is possible. This affords our customers the latest in technology and engineering.

OMEGA is a registered trademark of OMEGA ENGINEERING, INC.

© Copyright 2005 OMEGA ENGINEERING, INC. All rights reserved. This document may not be copied, photocopied, reproduced, translated, or reduced to any electronic medium or machine-readable form, in whole or in part, without the prior written consent of OMEGA ENGINEERING, INC.

PATENT AND TRADEMARK NOTICE: The "Meter Case Bezel Design" is a trademark of NEWPORT Electronics, Inc., registered in the U.S. USED UNDER LICENSE. This product is covered by one or more of the following patents: U.S. Pat. No. Des. 336,895; 5,274,577; 6,243,021 / CANADA 2052599; 2052600 / ITALY 1249456; 1250938 / GERMANY DE 41 34398 C2 / SPAIN 2039150; 2048066 / UK Patent No. GB2 249 837; GB2 248 954 / FRANCE BREVET NO. 91 12756. Other U.S. and International Patents pending or applied for.

WARNING: These products are not designed for use in, and should not be used for, patient-connected applications.

! This device is marked with the international caution symbol. It is important to read the Setup Guide before installing or commissioning this device, as the guide contains important information relating to safety and EMC.

It is the policy of OMEGA to comply with all worldwide safety and EMC/EMI regulations that apply. OMEGA is constantly pursuing certification of its products to the European New Approach Directives. OMEGA will add the CE mark to every appropriate device upon certification.

The information contained in this document is believed to be correct, but OMEGA Engineering, Inc. accepts no liability for any errors it contains, and reserves the right to alter specifications without notice.

TRADEMARK NOTICE:
Ω, **omega.com**, and **Ω OMEGA**, are Trademarks of OMEGA ENGINEERING, INC.

QUICK START



DP41-S
High Performance Strain Gage Indicator



OMEGAnet® On-Line Service www.omega.com	Internet e-mail info@omega.com
--	--

Servicing North America:

USA: ISO 9001 Certified	One Omega Drive, P.O. Box 4047 Stamford CT 06907-0047 TEL: (203) 359-1660 e-mail: info@omega.com	FAX: (203) 359-7700
Canada:	976 Bergar Laval (Quebec) H7L 5A1 TEL: (514) 856-6928 e-mail: info@omega.ca	FAX: (514) 856-6886

For immediate technical or application assistance:

USA and Canada:	Sales Service: 1-800-826-6342 / 1-800-TC-OMEGA® Customer Service: 1-800-622-2378 / 1-800-622-BEST® Engineering Service: 1-800-872-9436 / 1-800-USA-WHEN®
------------------------	--

Mexico and Latin American:	TEL: (001)800-TC-OMEGA® En Español: (001) 203-359-7803 e-mail: espanol@omega.com	FAX: (001) 203-359-7807
-----------------------------------	---	-------------------------

Servicing Europe:

Czech Republic:	Frystatska 184, 733 01 Karviná TEL: +420 59 6311899 e-mail: info@omegashop.cz	FAX: +420 59 6311114
Germany/Austria:	Daimlerstrasse 26, D-75392 Deckenpfronn, Germany TEL: +49 7056 9398-0 Toll Free in Germany: 0800 639 7678 e-mail: info@omega.de	FAX: +49 7056 9398-29
United Kingdom: ISO 9002 Certified	One Omega Drive River Bend Technology Centre Northbank, Irlam Manchester M44 5BD United Kingdom TEL: +44 161 777 6611 Toll Free in England: 0800 488 488 e-mail: sales@omega.co.uk	FAX: +44 161 777 6622

Using This Quick Start Manual

Use this Quick Start Manual to get your High Performance Strain Gage Indicator up and running right out of the box. These instructions use the factory default settings of **100mV unipolar input** and **10 Vdc sensor excitation**. If you have voltage or current input, refer to the main manual.

Note The latest complete Communication and Operational Manual as well as free Software are available at www.omega.com or on the CD-ROM enclosed with your shipment.

To start your unit:

- Connect ac power
- Wire the sensor
- Configure the meter, using the front panel buttons and the configuration menus

Your unit should have the following parts:

- Panel mounting gaskets
- ac Power Connector (orange P1), two Input Connectors (P3 and P9), and rear protective cover (mounted).

For detailed instructions, refer to the appropriate section in the Operator's Manual.

Before You Begin

In addition to the unit and related parts, you will need the following items to set up your unit:

- ac power as listed on meter's product/ID label
- External sensor (e.g.; load cell)
- 1/8" Phillips head screwdriver
- 1/8" flat blade screwdriver

Safety Consideration

Caution This device is marked with the international Caution symbol.

The instrument is a panel mount device protected in accordance with EN 61010-1:2001, electrical safety requirements for electrical equipment for measurement, control and laboratory. Remember that the unit has no power-on switch. Building installation should include a switch or circuit-breaker that must be compliant to IEC 947-1 and 947-3.

SAFETY:

- Do not exceed voltage rating on the label located on the top of the instrument housing.
- Always disconnect power before changing signal and power connections.
- Do not use this instrument on a work bench without its case for safety reasons.
- Do not operate this instrument in flammable or explosive atmospheres.
- Do not expose this instrument to rain or moisture.

EMC:

- Whenever EMC is an issue, always use shielded cables.
- Never run signal and power wires in the same conduit.
- Use signal wire connections with twisted-pair cables.
- Install Ferrite Bead(s) on signal wire close to the instrument if EMC problems persist.

Mount the Unit

1. Cut a panel opening using the dimensions shown to the right.
2. Position the unit in the opening, making sure the front bezel/gasket is flush with the panel.
3. From the rear of the panel, slide the sleeve forward over the case and up to the panel surface.
4. The panel should now be sandwiched between the bezel-backed gasket in front and the sleeve in back.
5. Replace the thumbnuts that secure the sleeve tabs to the case.

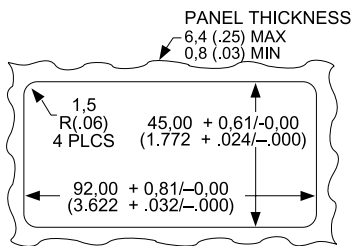

NOTE: Dimensions in Millimeters (Inches)

Warning: Do not connect AC power to your device until you have completed all input and output connections. This device must only be installed by a specially trained electrician with corresponding qualifications. Failure to follow all instructions and warnings may result in injury!

Connect ac Power

1. Remove the rear protective cover and set it aside. The cover is secured with a Phillips-head screw.
2. Locate connector P1 on the bottom-left-rear of the unit. The connector has three screw-down terminals (see below).
3. Insert the correct wire in each terminal and tighten the lockdown screw. Tug gently on each wire to verify the connection.

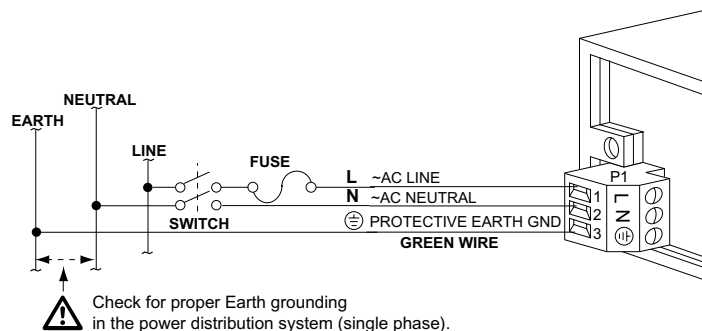

Wiring a Millivolt Output Sensor

The following example shows wiring a bridge input to the meter.

1. Locate connectors P3 and P9 on the right-side rear of the unit.
2. Attach the wires and tighten the retaining screws. Tug gently on the wires to verify the connection.

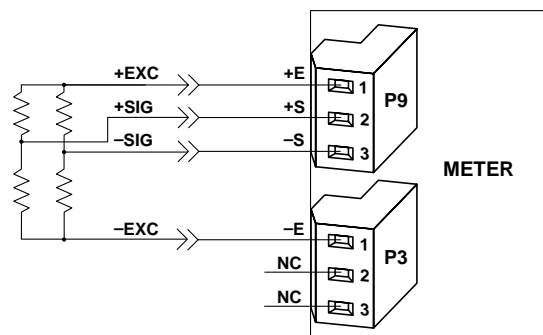

Wiring Example (Factory set at 10Vdc Excitation)

3. Apply ac power. The front panel of the unit flashes **RESET2**. If it does not:
 - a. Remove ac power.
 - b. Verify the P1 power and sensor connections.
 - c. Check your power source.
 - d. Apply ac power again.
4. Replace the rear cover. Thread the sensor wires through the slots on the side of the cover. Replace the rear cover retaining screw.

Determine Meter Scaling Factor

Calculate the scaling factor so the meter displays the desired engineering units. Assuming no known load, use the formula:

$$RDG\ SC = \text{display span} / [(\text{sensor's mV/V output}) (10,000)]$$

where: display span = desired display at full scale
sensor's output span = mV/V

Configure the Meter

Use the front panel buttons to access the configuration menus, to either verify or set the unit values. The first table that follows describes functions of each button on the front of the meter. The second table summarizes the key sequences you must press and the menus you will see to get your meter running. For a step-by-step procedure of specific tasks, refer to the configuration sections following the tables.

Meter Button Descriptions

Press This Button To:

- MENU**: Access the configuration program menus and move from one menu to the next.
- ▶/MIN**: Enter and scroll through a submenu.
- ▲/MAX**: Change the value of a submenu.
- RESET**: Move backward one menu (press once), or exit the configurations menus (press twice).
- SETPTS**: Change the Setpoints.

Key Sequences and Menus

MENU key	Submenu 1 (▶/MIN)	Action/Description
L1CNF		Skip past
L2CNF		Skip past
L3CNF		Skip past
L4CNF		Skip past
INPUT	BRIDGE	Select meter input Sub Menu 1 choice (BRIDGE)
RDGCNF	RDG1=0	Scaling y = mx+b
	RDG2=0	Active decimal point
	RDG3=0	Normal display brightness
	RDG4=1	Leading zeroes suppressed
	RDG5=0	Not used, skip past
	RDG6=1	Activates RDG SC/OF
	RDG7=0	External hard reset vs peak reset
RDG SC		See previous formula in "Determine Meter Scaling Factor" section.
RDG OF	000000	
INCNF	INP1=0	60 Hz ac power
	INP2=0	Slow reading (S1A jumper omitted)
	INP3=0	Unipolar input (S1B jumper omitted)
	INP4=0	Std. for BRIDGE inputs
	INP5=0	Not used, skip past
	INP6=0	Disables IN.SC.OF (Input Scale & Offset)
	INP7=1	Ratiometric input
INSCOF		Skip past
DEC PT	FFFFFF	Select decimal point
CNT BY		Press RESET twice

Now you are in RUN mode. If the meter does not read zero, refer to "Configure Reading Offset" section.

To Configure Type of Input:

1. Press MENU until the meter displays:

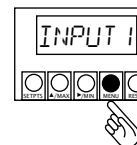

2. Press ▶/MIN to display a flashing input type.

3. Press MENU.
The meter displays:

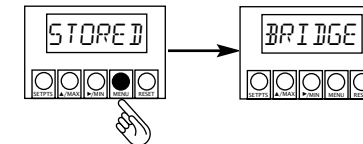

4. Press MENU and BRIDGE stops flashing.

5. Press MENU.
The meter displays:

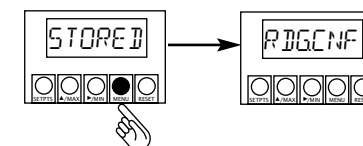

To Configure Meter Display Readings:

1. Press ▶/MIN to display:

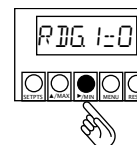

2. Press ▲/MAX, if necessary to change the configuration value to 0 or 1.
3. Repeat steps 1 and 2 for RDG2 through RDG7

4. Press MENU.
The meter displays:

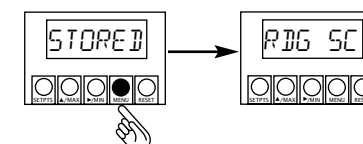

To Configure Scaling Factor:

1. Press ▶/MIN to display and to select the digit (or decimal point) you want to change.

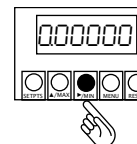

2. Press ▲/MAX to increase the value of the selected digit.
3. Repeat steps 1 and 2 until each digit is the desired value (your calculated scaling factor).

4. Press MENU
The meter displays:

