

5

Scaling With Known Loads (Continued)

6. Press **MENU** to store **IN 1**. The unit displays:

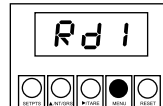

7. Press **▶/TARE**. The unit displays the last setting for **Rd 1**.

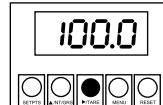

8. Change **Rd 1** as necessary:

- Press **▶/TARE** to scroll to the digit(s) you want to change (it flashes on the display).
- Press **▲/NT/GRS** to change the value of the flashing digit. Values can range from 0 to 9. For the first digit, you can also enter a minus sign (-) or -1.

9. Press **MENU** to store the value shown for **Rd 1**. The unit displays:

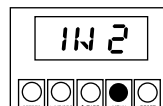

To identify the maximum known load (**IN 2** and **Rd 2**):

1. Apply the maximum known load (100%).
2. Repeat steps 4–9 above, for **IN 2** and **Rd 2**.

Once you've completed all steps, the unit displays:

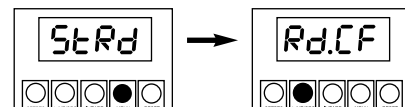

To begin operation:

Reinitialize the unit (press **RESET** twice or press **MENU** until **RSE** flashes on the display). When a numeric reading appears, the unit is operational.

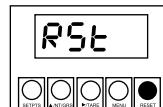

Scaling Without Known Loads

For 0–100 mV sensors, the values for the minimum and maximum input loads are always as follows:

- Minimum load (**IN 1**) — 0
- Maximum load (**IN 2**) — 9999.

If your installation uses a different sensor type, you must calculate the values for **IN 1** and **IN 2** before proceeding with the steps below. Use the formula provided in the Operator's Manual.

To define the minimum load (**IN 1** and **Rd 1**):

1. If it's not already shown, press **MENU** until the unit displays:



2. Press **▶/TARE**. The unit displays:

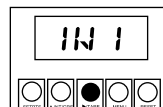

6

Scaling Without Known Loads (Continued)

3. Press **▶/TARE** again. The unit displays the last setting for **IN 1**. (The first digit flashes.)

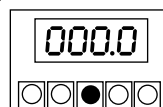

4. Change **IN 1** as necessary:

- Press **▲/NT/GRS** to set or change the digit's current value. Continue to press **▲/NT/GRS** until the meter displays the desired value for the flashing digit. Values can range from 0 to 9. For the first digit, you can also enter a minus sign (-) or -1.
- Press **▶/TARE** to scroll to the digit(s) you want to change.

5. Press **MENU** to store **IN 1**. The unit displays:

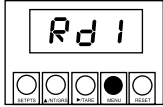

6. Press **▶/TARE**. The unit displays the last setting for **Rd 1**. (The first digit flashes.)

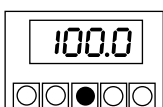

7. Change **Rd 1** as necessary:

- Press **▲/NT/GRS** until the meter displays the desired value for the flashing digit. Values can range from 0 to 9. For the first digit, you can also enter a minus sign (-) or -1.
- Press **▶/TARE** to scroll to the digit(s) you want to change.

8. Press **MENU** to store the value shown for **Rd 1**. The unit displays:

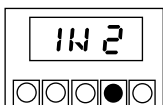

To define the maximum load (**IN 2** and **Rd 2**):

1. Repeat steps 3–8 above, entering the values for **IN 2** and **Rd 2**.
2. Once you've completed all steps, the unit displays:

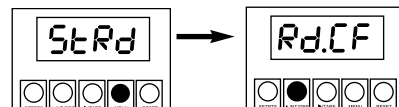

To begin operation:

Reinitialize the unit (press **RESET** twice or press **MENU** until **RSE** flashes on the display). When a numeric reading appears, the unit is operational.

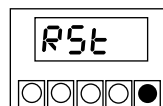

Determining Reading Offset

The run mode reading for meters scaled without known loads may reflect an offset. For example, say you set **Rd 1** to 0 and **Rd 2** to 100, but when the minimum load is applied, a negative value of -1.5 displays on the front panel.

To correct the reading offset:

1. With zero load applied, note the reading on the display.
2. Subtract that amount from the **Rd 1** and **Rd 2** values you originally entered.

In the example, the offset would be -1.5. If **Rd 1** is to read 0 in Run Mode, it must be reentered as 1.5. **Rd 2** must likewise be reentered as 101.5 if the meter is to read 100 when the maximum load is applied.
3. Repeat the steps for "Scaling Without Known Loads," but when the values for **IN 1** and **IN 2** display, do not change them. Instead, press **MENU** to move to the prompts for **Rd 1** and **Rd 2** and make the necessary changes.
4. Reinitialize the unit and resume operation.



DP25-S and DP25B-S Strain Meter



| | |
|---|--|
| OMEGAnet® On-Line Service www.omega.com | Internet e-mail info@omega.com |
|---|--|

Servicing North America:

| | | |
|-----------------------------------|---|---------------------|
| USA: ISO 9001 Certified | One Omega Drive, P.O. Box 4047 Stamford CT 06907-0047 TEL: (203) 359-1660 e-mail: info@omega.com | FAX: (203) 359-7700 |
| Canada: | 976 Bergar Laval (Quebec) H7L 5A1 TEL: (514) 856-6928 e-mail: info@omega.ca | FAX: (514) 856-6886 |

For immediate technical or application assistance:

| | |
|------------------------|--|
| USA and Canada: | Sales Service: 1-800-826-6342 / 1-800-TC-OMEGA® Customer Service: 1-800-622-2378 / 1-800-622-BEST® Engineering Service: 1-800-872-9436 / 1-800-USA-WHEN® |
|------------------------|--|

| | | |
|-----------------------------------|--|-------------------------|
| Mexico and Latin American: | TEL: (001)800-TC-OMEGA® En Español: (001) 203-359-7803 e-mail: espanol@omega.com | FAX: (001) 203-359-7807 |
|-----------------------------------|--|-------------------------|

Servicing Europe:

| | | |
|--|---|-----------------------|
| Czech Republic: | Frystatska 184, 733 01 Karviná TEL: +420 59 6311899 e-mail: info@omegashop.cz | FAX: +420 59 6311114 |
| Germany/Austria: | Daimlerstrasse 26, D-75392 Deckenpfronn, Germany TEL: +49 7056 9398-0 Toll Free in Germany: 0800 639 7678 e-mail: info@omega.de | FAX: +49 7056 9398-29 |
| United Kingdom: ISO 9002 Certified | One Omega Drive River Bend Technology Centre Northbank, Irlam Manchester M44 5BD United Kingdom TEL: +44 161 777 6611 Toll Free in England: 0800 488 488 e-mail: sales@omega.co.uk | FAX: +44 161 777 6622 |

MADE IN USA **WARRANTY/DISCLAIMER**

OMEGA ENGINEERING, INC. warrants this unit to be free of defects in materials and workmanship for a period of **one (1) year** from the date of purchase. In addition to OMEGA's standard warranty period, OMEGA Engineering will extend the warranty period for **four (4) additional years** if the warranty card enclosed with each instrument is returned to OMEGA.

If the unit malfunctions, it must be returned to the factory for evaluation. OMEGA's Customer Service Department will issue an Authorized Return (AR) number immediately upon phone or written request. Upon examination by OMEGA, if the unit is found to be defective, it will be repaired or replaced at no charge. OMEGA's WARRANTY does not apply to defects resulting from any action of the purchaser, including but not limited to mishandling, improper interfacing, operation outside of design limits, improper repair, or unauthorized modification. This WARRANTY is VOID if the unit shows evidence of having been tampered with or shows evidence of having been damaged as a result of excessive corrosion; or current, heat, moisture or vibration; improper specification; misapplication; misuse or other operating conditions outside of OMEGA's control. Components which wear are not warranted, including but not limited to contact points, fuses, and triacs.

OMEGA is pleased to offer suggestions on the use of its various products. However, OMEGA neither assumes responsibility for any omissions or errors nor assumes liability for any damages that result from the use of its products in accordance with information provided by OMEGA, either verbal or written. OMEGA warrants only that the parts manufactured by it will be as specified and free of defects. OMEGA MAKES NO OTHER WARRANTIES OR REPRESENTATIONS OF ANY KIND WHATSOEVER, EXPRESS OR IMPLIED, EXCEPT THAT OF TITLE, AND ALL IMPLIED WARRANTIES INCLUDING ANY WARRANTY OF MERCHANTABILITY AND FITNESS FOR A PARTICULAR PURPOSE ARE HEREBY DISCLAIMED. LIMITATION OF LIABILITY: The remedies of purchaser set forth herein are exclusive, and the total liability of OMEGA with respect to this order, whether based on contract, warranty, negligence, indemnification, strict liability or otherwise, shall not exceed the purchase price of the component upon which liability is based. In no event shall OMEGA be liable for consequential, incidental or special damages.

CONDITIONS: Equipment sold by OMEGA is not intended to be used, nor shall it be used: (1) as a "Basic Component" under 10 CFR 21 (NRC), used in or with any nuclear installation or activity; or (2) in medical applications or used on humans. Should any Product(s) be used in or with any nuclear installation or activity, medical application, used on humans, or misused in any way, OMEGA assumes no responsibility as set forth in our basic WARRANTY/DISCLAIMER language, and, additionally, purchaser will indemnify OMEGA and hold OMEGA harmless from any liability or damage whatsoever arising out of the use of the Product(s) in such a manner.

RETURN REQUESTS/INQUIRIES

Direct all warranty and repair requests/inquiries to the OMEGA Customer Service Department. BEFORE RETURNING ANY PRODUCT(S) TO OMEGA, PURCHASER MUST OBTAIN AN AUTHORIZED RETURN (AR) NUMBER FROM OMEGA'S CUSTOMER SERVICE DEPARTMENT (IN ORDER TO AVOID PROCESSING DELAYS). The assigned AR number should then be marked on the outside of the return package and on any correspondence.

The purchaser is responsible for shipping charges, freight, insurance and proper packaging to prevent breakage in transit.

| | |
|--|--|
| FOR WARRANTY RETURNS, please have the following information available BEFORE contacting OMEGA: 1. Purchase Order number under which the product was PURCHASED, 2. Model and serial number of the product under warranty, and 3. Repair instructions and/or specific problems relative to the product. | FOR NON-WARRANTY REPAIRS, consult OMEGA for current repair charges. Have the following information available BEFORE contacting OMEGA: 1. Purchase Order number to cover the COST of the repair, 2. Model and serial number of product, and 3. Repair instructions and/or specific problems relative to the product. |
|--|--|

OMEGA's policy is to make running changes, not model changes, whenever an improvement is possible. This affords our customers the latest in technology and engineering.
OMEGA is a registered trademark of OMEGA ENGINEERING, INC.
© Copyright 2006 OMEGA ENGINEERING, INC. All rights reserved. This document may not be copied, photocopied, reproduced, translated, or reduced to any electronic medium or machine-readable form, in whole or in part, without the prior written consent of OMEGA ENGINEERING, INC.

PATENT AND TRADEMARK NOTICE: The "Meter Case Bezel Design" is a trademark of NEWPORT Electronics, Inc., registered in the U.S. USED UNDER LICENSE. This product is covered by one or more of the following patents: U.S. Pat. No. Des. 336,895; 5,274,577; 6,243,021 / CANADA 2052599; 2052600 / ITALY 1249456; 1250938 / GERMANY DE 41 34398 C2 / SPAIN 2039150; 2048066 / UK Patent No. GB2 249 837; GB2 248 954 / FRANCE BREVET NO. 91 12756. Other U.S. and International Patents pending or applied for.

WARNING: These products are not designed for use in, and should not be used for, patient-connected applications.

This device is marked with the international caution symbol. It is important to read the Setup Guide before installing or commissioning this device, as the guide contains important information relating to safety and EMC.

It is the policy of OMEGA to comply with all worldwide safety and EMC/EMI regulations that apply. OMEGA is constantly pursuing certification of its products to the European New Approach Directives. OMEGA will add the CE mark to every appropriate device upon certification.

The information contained in this document is believed to be correct, but OMEGA Engineering, Inc. accepts no liability for any errors it contains, and reserves the right to alter specifications without notice.

TRADEMARK NOTICE:
Ω, **omega.com**, and **Ω OMEGA**, are Trademarks of OMEGA ENGINEERING, INC.

Using This Quick Start Manual

Use this Quick Start Manual to set up your Strain Meter and begin operation. Information is provided on how to:

- Connect ac power
- Set basic options for operation
- Connect the sensor
- Scale the meter.

Features with  are for the "B" version which has three-color programmable "Big" LED display - All segment characters shown are for the "B" version.

 **IMPORTANT:** For complete information on all setup options, please refer to the Operator's Manual.

 This Quick Start Manual includes specific configuration parameters for bridge sensors with an output range of 0-100 mV and 10 V excitation. Other sensor types may require different parameters or additional ones. When this is the case, we refer you to the Operator's Manual for detailed instructions.

Safety Consideration

 This device is marked with the international Caution symbol.

The instrument is a panel mount device protected in accordance with EN 61010-1:2001, electrical safety requirements for electrical equipment for measurement, control and laboratory. Remember that the unit has no power-on switch. Building installation should include a switch or circuit-breaker that must be compliant to IEC 947-1 and 947-3.

SAFETY:

- Do not exceed voltage rating on the label located on the top of the instrument housing.
- Always disconnect power before changing signal and power connections.
- Do not use this instrument on a work bench without its case for safety reasons.
- Do not operate this instrument in flammable or explosive atmospheres.
- Do not expose this instrument to rain or moisture.

EMC:

- Whenever EMC is an issue, always use shielded cables.
- Never run signal and power wires in the same conduit.
- Use signal wire connections with twisted-pair cables.
- Install Ferrite Bead(s) on signal wire close to the instrument if EMC problems persist.

Mount the Unit

1. Cut a panel opening using the dimensions shown to the right.
2. Position the unit in the opening, making sure the front bezel is flush with the panel.
3. Install retaining clips on both sides of the meter and tighten against the panel.

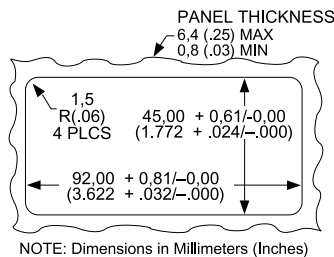

Wiring

 **Warning:** Do not connect AC power to your device until you have completed all input and output connections. This device must only be installed by a specially trained electrician with corresponding qualifications. Failure to follow all instructions and warnings may result in injury!

1. Remove the panel at the back of the unit.
2. Locate the TB1 connector.
3. Insert the correct wire in each terminal as shown in the following figure and tighten the lockdown screws.
4. Tug gently on the wires to verify the connections.

External Fuse Required:

Time-delay, UL 248-14 listed Time-lag, IEC 127-3 recognized
 175 mA (115 Vac line) 125 mA (115 Vac line)
 80 mA (230 Vac line) 63 mA (230 Vac line)

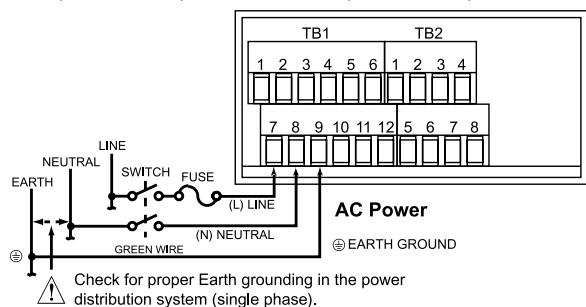

AC Powered Unit Connections

Wiring (continued)

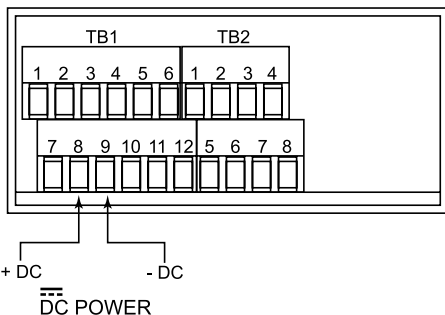

 When using DC power, do not use internal excitation or Isolated Analog Output for high color brightness. For low or medium brightness, internal excitation is limited to 24 V @ 25 mA; 5 V, 12 V, 12 V @ 35 mA.

 In order to maintain the same degree of protection as the AC units, always use a Safety Agency Approval DC source with the same Overvoltage Category and Pollution Degree.

DC Powered Unit Connections

Connect the Sensor

1. Locate the TB2 connector on the rear of the unit.
2. Attach the sensor wires and tighten the lockdown screws. The diagram below shows the wiring for bridge sensors with internal excitation.

 Refer to the Operator's Manual for setup requirements for other sensor types.

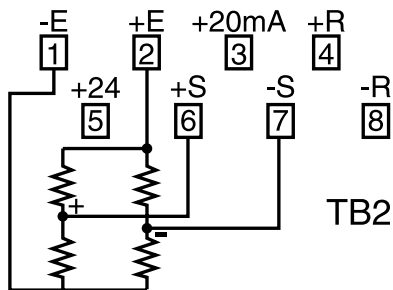

Bridge Sensor with Internal Excitation

3. Tug gently on the wires to verify the connections.
4. Replace the panel at the back of the unit.

Using the Configuration Menu

To configure the meter, you use the buttons on the front panel.

| To: | Take This Action: |
|--|---|
| Display the Configuration Menu | Press the MENU button. The first function on the menu, INPE , displays. |
| Select a submenu function | <ol style="list-style-type: none"> 1. Press MENU until the function you want is shown. 2. Press ▶/TARE. The information you can change flashes. |
| Select a value for that submenu function | <ol style="list-style-type: none"> 1. Press ▲/NT/GRS to display the option you want. 2. Press MENU to store it. StRd quickly flashes, indicating that the selection has been stored in memory. Then the next menu function displays. |
| Go back to previous menu function | Press RESET once. |
| Exit the Configuration Menu | Press RESET twice. The unit displays RSE as it reinitializes. When a numeric value displays, the unit is in run mode. (Optionally, you can press MENU to move through all the menu functions until the unit reinitializes.) |

Using the Configuration Menu (continued)

| MENU | SUBMENU | ▶/TARE | DESCRIPTION |
|---------|--|--------|-----------------------------|
| INPE | 100M, 50M, 10M, 5M, 0-20* | | Input |
| dECP | FFFF*, F.FFF, FF.FF, FFF.F | | Decimal Point |
| Rd.S.0 | IN 1, Rd 1, IN 2, Rd 2 | | Scale and Offset |
| Rd.CF | R.1=E*, R.1=N R.2=0, R.2=1, R.2=2, R.2=3, R.2=4* R.3=F*, R.3=U R.4=P, R.4=0 | | Reading Configuration |
| COLR | GRN, Red, ARbR | | Display Color |
| S1.CF | S.1=A*, S.1=B S.2=U*, S.2=L S.3=N*, S.3=0 shown if R.4=G | | Setpoint 1 Configuration |
| S2.CF | S.1=A*, S.1=B S.2=U*, S.2=L S.3=N*, S.3=0 shown if R.4=G | | Setpoint 2 Configuration |
| S1.db | 0003* | | Setpoint 1, Deadband |
| S2.db | 0003* | | Setpoint 2, Deadband |
| Out.CF | 0.1=E*, 0.1=d 0.2=C*, 0.2=V 0.3=A*, 0.3=P | | Analog Output Configuration |
| Out.S.0 | Rd 1, Out 1, Rd 2, Out 2 | | Output Scale & Offset |
| Lk.CF | R5=E*, R5=d SP=E*, SP=d L3=0*, L3=1 | | Lockout Configuration |
| BRtE | ArbE, brE, W.brE | | Display Brightness |

* Factory Default Settings

To Set the Input Type

1. Press **MENU** until the unit displays:

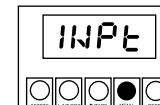

2. Press **▶/TARE**. The unit displays:

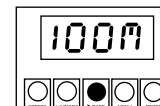

3. For this application you want **100M**. If **100M** is not displayed, press **▲/NT/GRS** until it appears. Other choices are **50M**, **10M**, **5M** and **0-20**.

 Refer to the Operator's Manual for more information on changing ranges.

4. Press **MENU** to select the sensor shown. The meter displays the next menu item. If you changed input type, the meter displays:

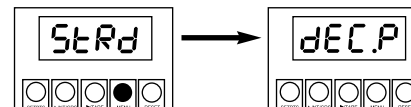

To Set the Decimal Point

1. If it's not already shown, press **MENU** until the unit displays:

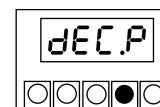

2. Press **▶/TARE**. The unit displays:

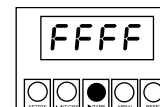

To Set the Decimal Point (continued)

3. Press **▲/NT/GRS** to move the decimal point to the desired location. The factory settings is **FFFF**. The other choices are **F.FFF**, **FF.FF**, and **FFF.F**.

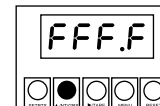

4. Press **MENU** to select the decimal point position shown. The unit displays:

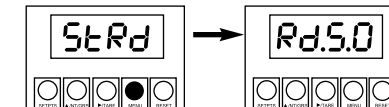

To Scale the Meter

You can scale the meter in one of two ways:

1. With a known load — This method uses input (load) information sent from another device such as a scale or a simulator for voltage or current.
2. Without a known load — This involves calculating the load based on transducer specifications and manually entering it to the meter.

For both methods, you must first identify the minimum input load **IN 1** and the corresponding display reading you want **Rd 1**. Then you identify the maximum input load **IN 2** and its corresponding display reading **Rd 2**.

 The decimal point is for display purposes only — you set it where you want it to display for your application.

When entering **IN 1** and **IN 2** values, ignore any decimal point on the display. However, you must enter **Rd 1** and **Rd 2** values with the decimal point in the desired position.

Scaling With Known Loads

To identify the minimum known load (**IN 1** and **Rd 1**):

1. If it's not already shown, press **MENU** until the unit displays:



2. Apply the minimum known load (0%).

3. Press **▶/TARE**. The unit displays:

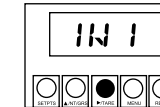

4. Press **▶/TARE** again. The unit displays the last setting for **IN 1**.

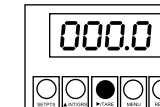

5. Press **▶/TARE** again. The unit displays the actual reading being received from the sending device.

