

Resistance Elements and RTD's

David J. King

INTRODUCTION

Resistance elements come in many types conforming to different standards, capable of different temperature ranges, with various sizes and accuracies available. But they all function in the same manner: each has a pre-specified resistance value at a known temperature which changes in a predictable fashion. In this way, by measuring the resistance of the element, the temperature of the element can be determined from tables, calculations or instrumentation. These resistance elements are the heart of the RTD (Resistance Temperature Detector). Generally, a bare resistance element is too fragile and sensitive to be used in its raw form, so it must be protected by incorporating it into an RTD. A

Resistance Temperature Detector is a general term for any device that senses temperature by measuring the change in resistance of a material. RTD's come in many forms, but usually appear in sheathed form. An RTD probe is an assembly composed of a resistance element, a sheath, lead wire and a termination or connection. The sheath, a closed end tube, immobilizes the element, protecting it against moisture and the environment to be measured. The sheath also provides protection and stability to the transition lead wires from the fragile element wires.



Some RTD probes can be combined with thermowells for additional protection. In this type of application, the thermowell may not only add protection to the RTD, but will also seal whatever system the RTD is to measure (a tank or boiler for instance) from actual contact with the RTD. This becomes a great aid in replacing the RTD without draining the vessel or system.

Thermocouples are the old tried and true method of electrical temperature measurement. They function very differently from RTD's but generally appear in the same configuration: often sheathed and possibly in a thermowell.

Basically, they operate on the Seebeck effect, which results in a change in thermoelectric emf induced by a change in temperature. Many applications lend themselves to either RTD's or thermocouples.

Thermocouples tend to be more rugged, free of self-heating errors and they command a large assortment of instrumentation. However, RTD's, especially platinum RTD's, are more stable and accurate.

RESISTANCE ELEMENT CHARACTERISTICS

There are several very important details that must be specified in order to properly identify the characteristics of the RTD:

1. Material of Resistance Element (Platinum, Nickel, etc.)
2. Temperature Coefficient
3. Nominal Resistance
4. Temperature Range of Application
5. Physical Dimensions or Size Restrictions
6. Accuracy

1. Material of Resistance Element

Several metals are quite common for use in resistance elements and the purity of the metal affects its characteristics. Platinum is by far the most popular due to its linearity with temperature. Other common materials are nickel and copper, although most of these are being replaced by platinum elements. Other metals used, though rarely, are Balco (an iron-nickel alloy), tungsten and iridium.

2. Temperature Coefficient

The temperature coefficient of an element is a physical and electrical property of the material. This is a term that describes the average resistance change per unit of temperature from ice point to the boiling point of water. Different organizations have adopted different temperature coefficients as their standard. In 1983, the IEC (International Electrotechnical Commission) adopted the DIN (Deutsche Institute for Normung) standard of Platinum 100 ohm at 0°C with a temperature coefficient of 0.00385 ohms per ohm degree centigrade. This is now the accepted standard of the industry in most countries, although other units are widely used. A quick explanation of how the coefficient is derived is as follows: Resistance at the boiling point (100°C) = 138.50 ohms. Resistance at ice point (0°C) = 100.00 ohms. Divide the difference (38.5) by 100 degrees and then divide by the 100 ohm

nominal value of the element. The result is the mean temperature coefficient (alpha) of 0.00385 ohms per ohm per °C.

Some of the less common materials and temperature coefficients are:

Pt TC	=	.003902 (U.S. Industrial Standard)
Pt TC	=	.003920 (Old U.S. Standard)
Pt TC	=	.003923 (SAMA)
Pt TC	=	.003916 (JIS)
Copper TC	=	.0042
Nickel TC	=	0.00617 (DIN)
Nickel TC	=	.00672 (Growing Less Common in U.S.)
Balco TC	=	.0052
Tungsten TC	=	0.0045

Please note that the temperature coefficients are the average values between 0 and 100°C. This is not to say that the resistance vs. temperature curves are truly linear over the specified temperature range.

3. Nominal Resistance



Nominal Resistance is the pre-specified resistance value at a given temperature. Most standards, including IEC-751, use 0°C as their reference point. The IEC standard is 100 ohms at 0°C, but other nominal resistances, such as 50, 200, 400, 500, 1000 and 2000 ohm, are available.

4. Temperature Range of Application

Depending on the mechanical configuration and manufacturing methods, RTD's may be used from -270°C to 850°C. Specifications for temperature range will be different, for thin film, wire wound and glass encapsulated types, for example.

5. Physical Dimensions or Size Restrictions

The most critical dimension of the element is outside diameter (O.D.), because the element must often fit within a protective sheath. The film type elements have no O.D. dimension. To calculate an equivalent dimension, we need to find the diagonal of an end cross section (this will be the widest distance across the element as it is inserted into a sheath).

Resistance Elements and RTD's Cont'd

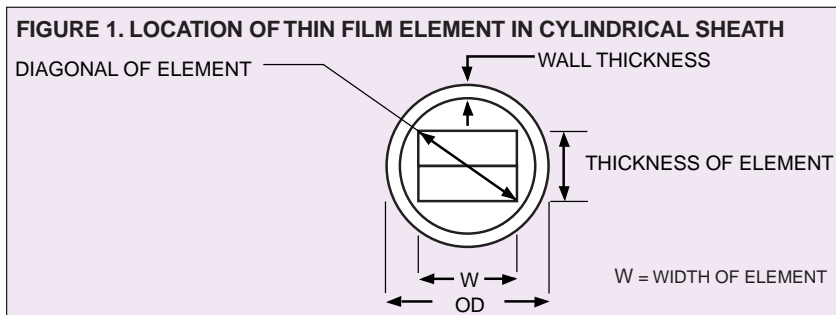

Permissible deviations from basic values

Class A		
Temperature °C	Deviation	
	ohms	°C
-200	±0.24	±0.55
-100	±0.14	±0.35
0	±0.06	±0.15
100	±0.13	±0.35
200	±0.20	±0.55
300	±0.27	±0.75
400	±0.33	±0.95
500	±0.38	±1.15
600	±0.43	±1.35
650	±0.46	±1.45

Class B		
Temperature °C	Deviation	
	ohms	°C
-200	±0.56	±1.3
-100	±0.32	±0.8
0	±0.12	±0.3
100	±0.30	±0.8
200	±0.48	±1.3
300	±0.64	±1.8
400	±0.79	±2.3
500	±0.93	±2.8
600	±1.06	±3.3
650	±1.13	±3.6
700	±1.17	±3.8
800	±1.28	±4.3
850	±1.34	±4.6

For example, using an element that is 10 x 2 x 1.5 mm, the diagonal can be found by taking the square root of (2² + 1.5²). Thus, the element will fit into a 2.5 mm (0.98") inside diameter hole. For practical purposes, remember that any element 2 mm wide or less will fit into a

1/8" O.D. sheath with 0.010" walls, generally speaking. Elements which are 1.5 mm wide will typically fit into a sheath with 0.084" bore. Refer to Figure 1.

6. Accuracy

IEC 751 specifications for Platinum Resistance Thermometers have adopted DIN 43760 requirements for accuracy. DIN-IEC Class A and Class B elements are shown in the chart on this page.

7. Response Time

50% Response is the time the thermometer element needs in order to reach 50% of its steady state value. 90% Response is defined in a similar manner. These response times of elements are given for water flowing with 0.2 m/s velocity and air flowing at 1 m/s. They can be calculated for any other medium with known values of thermal conductivity. In a 1/4" diameter sheath immersed in water flowing at 3 feet per second, response time to 63% of a step change in temperature is less than 5.0 seconds.

8. Measurement Current and Self Heating

Temperature measurement is carried out almost exclusively with direct current. Unavoidably, the measuring current generates heat in the RTD. The permissible measurement currents are determined by the location of the element, the medium which is to be measured, and the velocity of moving media. A self-heating factor, "S", gives the measurement error for the element in °C per milliwatt (mW). With a given value of measuring current, I, the milliwatt value P can be calculated from P = I²R, where R is the RTD's resistance value. The temperature measurement error ΔT (°C) can then be calculated from ΔT = P x S.

RESISTANCE ELEMENT SPECIFICATIONS

Stability: Better than 0.2°C after

10,000 hours at maximum temperature (1 year, 51 days, 16 hours continuous).

Vibration Resistance: 50 g @ 500°C; 200 g @ 20°C; at frequencies from 20 to 1000 cps.

Temperature Shock Resistance: In forced air: over entire temperature range. In a water quench: from 200 to 20°C.

Pressure Sensitivity: Less than 1.5 x 10⁻⁴ C/PSI, reversible.

Self Heating Errors & Response

Times: Refer to specific Temperature Handbook pages for the type of element selected.

Self Inductance From Sensing

Current: Can be considered negligible for thin film elements; typically less than 0.02 microhenry for wire wound elements.

Capacitance: For wire wound elements: calculated to be less than 6 PicoFarads; for film-type elements: capacitance is too small to be measured and is affected by lead wire connection. Lead connections with element may indicate about 300 pF capacitance.

LEAD WIRE CONFIGURATIONS

As stated previously, a Resistance Temperature Detector (RTD) element generally appears in a sheathed form. Obviously, all of the criteria applicable to resistance elements also apply here, but rather than element size, the construction and dimensions of the entire RTD assembly must be considered. Since the lead wire used between the resistance element and the measuring instrument has a resistance itself, we must also supply a means of compensating for this inaccuracy. Refer to Figure 2 for the 2-wire configuration.

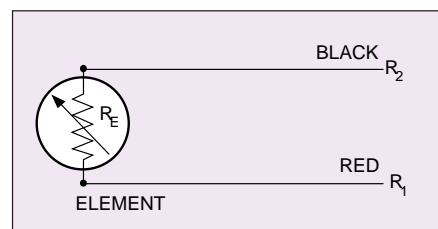

FIGURE 2. 2-WIRE CONFIGURATION (STYLE 1)

The circle represents the resistance element boundaries to the point of calibration. 3- or 4-wire configuration must be extended from the point of calibration so that all uncalibrated resistances are compensated.

The resistance R_E is taken from the resistance element and is the value that will supply us with an accurate temperature measurement. Unfortunately, when we take our resistance measurement, the instrument will indicate

$$R_{TOTAL}$$

Where

$$R_T = R_1 + R_2 + R_E$$

This will produce a temperature readout higher than that actually being measured. Many systems can be calibrated to eliminate this. Most RTD's incorporate a third wire with resistance R_3 . This wire will be connected to one side of the resistance element along with lead 2 as shown in Figure 3.

This configuration provides one connection to one end and two to the other end of the sensor. Connected to an instrument designed to accept 3-wire input, compensation is achieved for lead resistance and temperature change in lead resistance. This is the most commonly used configuration.

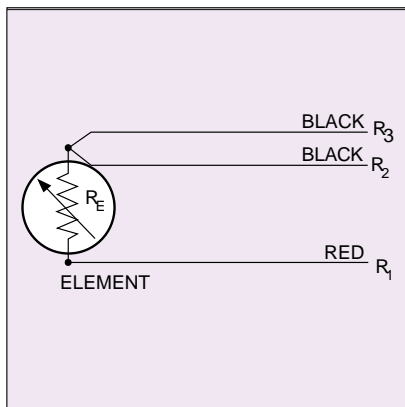

FIGURE 3. 3-WIRE CONFIGURATION (STYLE 2)

If three identical type wires are used and their lengths are equal, then $R_1 = R_2 = R_3$. By measuring the resistance through leads 1, 2 and the resistance element, a total system resistance is measured ($R_1 + R_2 + R_E$). If the resistance is also measured through leads 2 and 3 ($R_2 + R_3$), we obtain the resistance of just the lead wires, and since all lead wire resistances are equal, subtracting this value ($R_2 + R_3$) from the total system resistance ($R_1 + R_2 + R_E$) leaves us with just R_E , and an accurate temperature measurement has been made. A 4-wire configuration is also used. (See Figure 4.) Two connections are

provided to each end of the sensor. This construction is used for measurements of the highest precision.

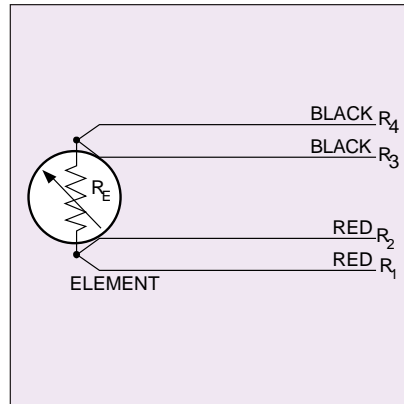
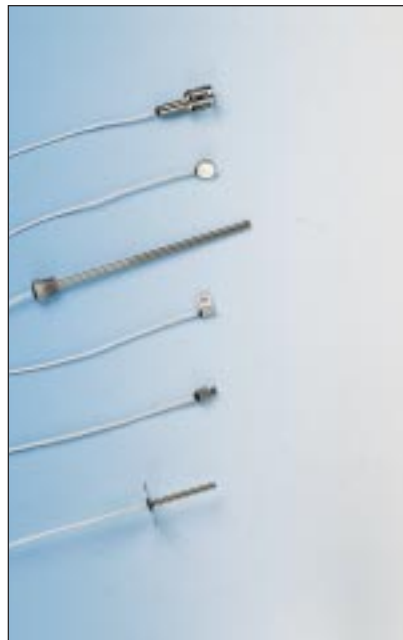

FIGURE 4. 4-WIRE CONFIGURATION (STYLE 3)

With the 4-wire configuration, the instrument will pass a constant current (I) through the outer leads, 1 and 4.

The voltage drop is measured across the inner leads, 2 and 3. So from $V = IR$ we learn the resistance of the element alone, with no effect from the lead wire resistance. This offers an advantage over 3-wire configurations only if dissimilar lead wires are used, and this is rarely the



case.

Still another configuration, now rare, is a standard 2-wire configuration with a closed loop of wire alongside (Figure 5). This functions the same as the 3-wire configuration, but uses an extra wire to do so. A separate pair of wires is provided as a loop to provide compensation for lead resistance and ambient changes in lead resistance.

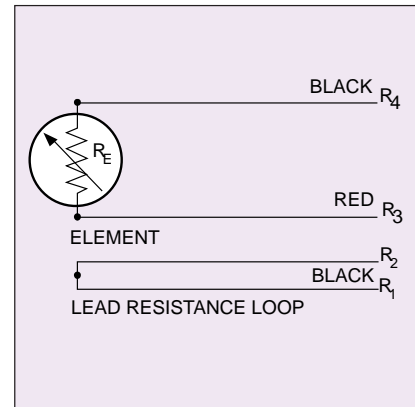

FIGURE 5. 2-WIRE CONFIGURATION PLUS LOOP (STYLE 4)





UNITED STATES

www.omega.com
1-800-TC-OMEGA
Stamford, CT.

CANADA

www.omega.ca
Laval(Quebec)
1-800-TC-OMEGA

GERMANY

www.omega.de
Deckenpfronn, Germany
0800-8266342

UNITED KINGDOM

www.omega.co.uk
Manchester, England
0800-488-488

FRANCE

www.omega.fr
Guyancourt, France
088-466-342

CZECH REPUBLIC

www.omegaeng.cz
Karviná, Czech Republic
596-311-899

BENELUX

www.omega.nl
Amstelveen, NL
0800-099-33-44



More than 100,000 Products Available!

• Temperature

Calibrators, Connectors, General Test and Measurement Instruments, Glass Bulb Thermometers, Handheld Instruments for Temperature Measurement, Ice Point References, Indicating Labels, Crayons, Cements and Lacquers, Infrared Temperature Measurement Instruments, Recorders Relative Humidity Measurement Instruments, RTD Probes, Elements and Assemblies, Temperature & Process Meters, Timers and Counters, Temperature and Process Controllers and Power Switching Devices, Thermistor Elements, Probes and Assemblies, Thermocouples Thermowells and Head and Well Assemblies, Transmitters, Wire

• Flow and Level

Air Velocity Indicators, Doppler Flowmeters, Level Measurement, Magnetic Flowmeters, Mass Flowmeters, Pitot Tubes, Pumps, Rotameters, Turbine and Paddle Wheel Flowmeters, Ultrasonic Flowmeters, Valves, Variable Area Flowmeters, Vortex Shedding Flowmeters

• pH and Conductivity

Conductivity Instrumentation, Dissolved Oxygen Instrumentation, Environmental Instrumentation, pH Electrodes and Instruments, Water and Soil Analysis Instrumentation

• Data Acquisition

Auto-Dialers and Alarm Monitoring Systems, Communication Products and Converters, Data Acquisition and Analysis Software, Data Loggers Plug-in Cards, Signal Conditioners, USB, RS232, RS485 and Parallel Port Data Acquisition Systems, Wireless Transmitters and Receivers

• Pressure, Strain and Force

Displacement Transducers, Dynamic Measurement Force Sensors, Instrumentation for Pressure and Strain Measurements, Load Cells, Pressure Gauges, Pressure Reference Section, Pressure Switches, Pressure Transducers, Proximity Transducers, Regulators, Strain Gages, Torque Transducers, Valves

• Heaters

Band Heaters, Cartridge Heaters, Circulation Heaters, Comfort Heaters, Controllers, Meters and Switching Devices, Flexible Heaters, General Test and Measurement Instruments, Heater Hook-up Wire, Heating Cable Systems, Immersion Heaters, Process Air and Duct, Heaters, Radiant Heaters, Strip Heaters, Tubular Heaters