

# Infrared Fiber Optic Polymer Bolt Temperature System

Series 4121  
**\$2195**  
 All Models

**Model 4121**  
 Polymelt Temperature  
 System 98 to 463°C  
 (210 to 865°F)  
 In Sub Ranges



4121-G-F-J, infrared detector, \$2195.

2120-6-2516-T1-7-1-2 polymelt probe, \$1170.

Both models shown smaller than actual size.

- ✓ **Response Time**  
10 Milliseconds
- ✓ **Fiber Optic Cable**
- ✓ **Withstands Pressure**  
up to 30,000 psi
- ✓ **FM and CSA Approved**  
**Intrinsically Safe Models**  
Available Steel Construction
- ✓ **High Operating Temperature**
- ✓ **Hermetically Sealed for Harsh Environments**

The 4121 Polymelt System offers a unique non-contact method of measuring polymer melt temperatures. Unlike thermocouples, its 10 millisecond response time provides unsurpassed real-time temperature data and tighter process control. Since the probe tip is flush with the barrel's ID, it "looks into" the melt and is completely non-intrusive, producing no error due to polymer shear effects or heat sinking.

This compact and rugged system allows maximum installation flexibility and requires a minimum amount of space for installation. The 4121 polymelt system offers a fast and accurate method to monitor polymer temperature in the extruder nozzle or barrel or in the injection molding cavity.

The polymelt transducer system incorporates a chopper stabilizing detector for drift free operation and is directly interchangeable with thermocouple instrumentation such as meters or controllers with cold junction compensation. The 4121 is manufactured using advanced laser

soldering technology and incorporates surface-mount devices for exceptional reliability and compactness.

The 4121 polymelt system consists of a patented polymer probe with a rugged, flexible fiber optic cable assembly. The probe tip contains an abrasion resistant sapphire window which is capable of withstanding 30,000 psi pressure. The standard Hastelloy tip allows use on more abrasive polymer materials. The fiber optic assembly easily connects to the transducer. The 4121 polymelt system output ties directly to dataloggers, process controllers, and recorders. It incorporates a digital emissivity control for precise and repeatable setting of emissivity.

### Specifications

**Temperature Range:** 98 to 463°C (210 to 865°F) (in sub-ranges)  
**Temperature Accuracy:** ±1% of reading

**Linearization Accuracy:** ±1% of reading or 2°C, 4°F, whichever is greater  
**Emissivity Control:** 0.10 to 0.99 in 0.01 steps  
**Output:** 1 mV/° standard, secondary output either 4 to 20 mA, 0 to 10 Vdc, J T/C  
**Ambient Temperature:**  
**Model 4121:** 10 to 50°C (50 to 122°F)  
**Fiber Optics:** 10 to 150°C (50 to 300°F)  
**Spectral Response:** 1.0 to 2.7 microns  
**Response Time:** 10 ms  
**Power Supply:** ±15 Vdc, 100 mA (±0.05% regulation)  
**Power Consumption:** 2 W  
**Mating Cable Connector:** Bendix PT06A-10-65SR  
**Dimensions:**  
**Model 4121:** 62 Dia. x 185 mm L (2.43 x 7.3")  
**Fiber Optic Probe:** See dimensional diagrams  
**Weight:**  
**Series 4121 Detector:** 0.9 kg (2 lb)  
**Fiber Optics:** 0.7 kg (1.5 lb)

## Series 2120

**\$1170**

Series 2120 standard polymer probe is available in lengths from 165 to 305 mm (6.5 to 12.00") and is installed as shown below. The fiber optic cable is permanently attached to the bolt assembly. The air purge fitting is at 90° from the probe body.

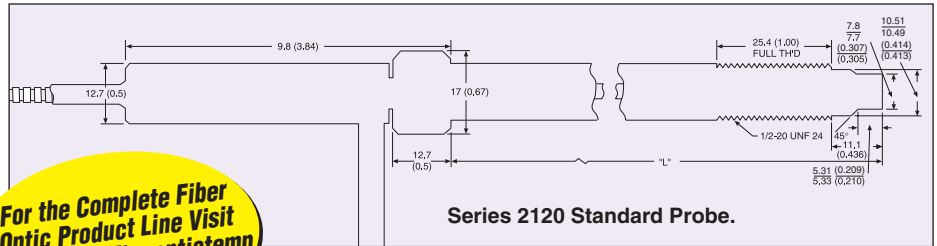

Dimensions: mm (in)

## Series 2108

**\$1290**

Series 2108 quick-disconnect polymer probe, measuring as small as 76 mm (3") overall, is used where the available mounting space is at a premium. The fiber bundle exits the probe at a right angle and is easily removable from the probe body by a knurled twist nut. Air purge fitting is at 60° from the probe body.

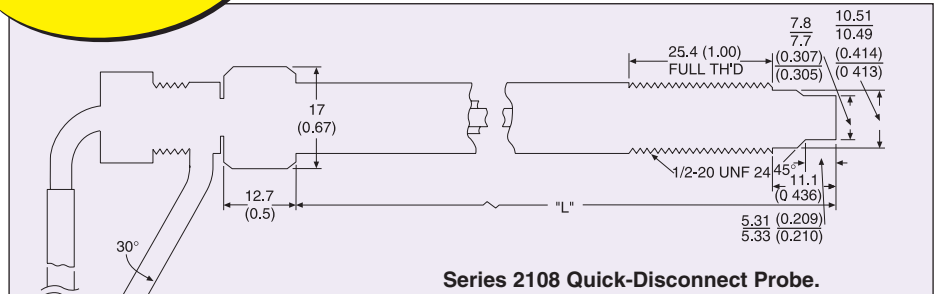

For the Complete Fiber Optic Product Line Visit [omega.com/fiberoptictemp](http://omega.com/fiberoptictemp)



OMEGACARE<sup>SM</sup> extended warranty program is available for models shown on this page. Ask your sales representative for full details when placing an order. OMEGACARE<sup>SM</sup> covers parts, labor and equivalent loaners.

**MOST POPULAR MODEL HIGHLIGHTED!**

### 4121 Infrared Detectors<sup>†</sup>

#### To Order (Specify Model Number)

Model No.	Price	Description	Outputs
4121-G-F-1	\$2195	Infrared detector	1 mV/° and 0 to 10 Vdc outputs
4121-G-F-4	2195	Infrared detector	1 mV/° and 4 to 20 mA outputs
4121-G-F-J	2195	Infrared detector	1 mV/° and J outputs

<sup>†</sup> Note: A complete system consists of a Series 4121 detector and either the 2120 or 2108 fiber optic probe assembly. You must order at least one detector and one probe from the tables below.

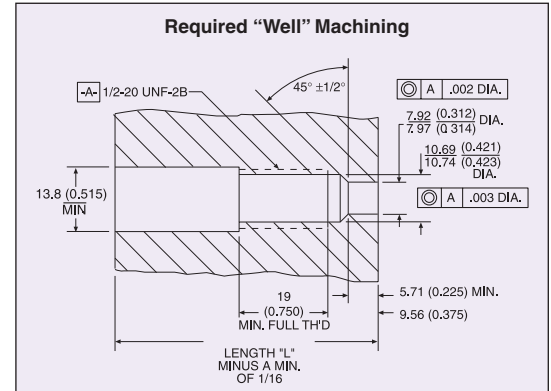

### Fiber Optic Polymer Bolt Assemblies (Both styles are fitted for air purging)

Model No.	Price	Temperature Range	Cable Length
<b>Fiber Optic Assembly with Standard Polymer Bolt (with fiber optic cable hardwired to bolt)</b>			
2120-(*)-2516-T1-7-1-2	\$1170	98 to 316°C (210 to 600°F)	0.3 m (1') fiber optic cable
2120-(*)-2516-T1-7-2-2	1190	121 to 371°C (250 to 700°F)	0.6 m (2') fiber optic cable
2120-(*)-2516-T1-7-3-2	1210	135 to 390°C (275 to 735°F)	1 m (3') fiber optic cable
2120-(*)-2516-T1-7-4-2	1240	154 to 415°C (310 to 780°F)	1.2 m (4') fiber optic cable
2120-(*)-2516-T1-7-5-2	1265	163 to 438°C (325 to 820°F)	1.5 m (5') fiber optic cable
2120-(*)-2516-T1-7-6-2	1290	174 to 463°C (345 to 865°F)	1.8 m (6') fiber optic cable
<b>Fiber Optic Assembly with Quick Disconnect Polymer Bolt (with right angle fiber optic cable for disconnecting fiber optic cable from bolt)</b>			
2108-(**)-2008-0001-1	\$1290	98 to 316°C (210 to 600°F)	0.3 m (1') fiber optic cable
2108-(**)-2008-0001-2	1320	121 to 371°C (250 to 700°F)	0.6 m (2') fiber optic cable
2108-(**)-2008-0001-3	1360	135 to 390°C (275 to 735°F)	1 m (3') fiber optic cable
2108-(**)-2008-0001-4	1390	154 to 415°C (310 to 780°F)	1.2 m (4') fiber optic cable
2108-(**)-2008-0001-5	1425	163 to 438°C (325 to 820°F)	1.5 m (5') fiber optic cable
2108-(**)-2008-0001-6	1460	174 to 463°C (345 to 865°F)	1.8 m (6') fiber optic cable

\* Insert 6 to 12" probe length.

\*\* Insert 3 to 12" probe length.

Comes complete with mounting bracket, 3 m (10') of power/output cable, NIST calibration and operator's manual.

**Ordering Examples:** 4121-G-F-J, Series 4121 infrared detector with 1 mV/° and Type J thermocouple outputs and 2108-3-2008-0001-3, quick-disconnect polymelt probe, 3" long, with a 3' fiber optic cable, and a 135 to 390°C (275 to 735°F) temperature range, \$2195 + 1360 = **\$3555**.

4121-G-F-4, Series 4121 infrared detector with 1 mV/° and 4 to 20 mA outputs and 2120-7-2516-T1-7-4-2, standard polymelt probe, 7" long, with a 4' fiber optic cable, and a 154 to 415°C (310 to 780°F) temperature range, \$2195 + 1240 = **\$3435**.

OCW-3, OMEGACARE<sup>SM</sup> extends standard 1-year warranty to a total of 4 years (**\$350**), \$2195 + 350 = **\$2545**.



#### UNITED STATES

[www.omega.com](http://www.omega.com)  
1-800-TC-OMEGA  
Stamford, CT.

#### CANADA

[www.omega.ca](http://www.omega.ca)  
Laval(Quebec)  
1-800-TC-OMEGA

#### GERMANY

[www.omega.de](http://www.omega.de)  
Deckenpfronn, Germany  
0800-8266342

#### UNITED KINGDOM

[www.omega.co.uk](http://www.omega.co.uk)  
Manchester, England  
0800-488-488

#### FRANCE

[www.omega.fr](http://www.omega.fr)  
Guyancourt, France  
088-466-342

#### CZECH REPUBLIC

[www.omegaeng.cz](http://www.omegaeng.cz)  
Karviná, Czech Republic  
596-311-899

#### BENELUX

[www.omega.nl](http://www.omega.nl)  
Amstelveen, NL  
0800-099-33-44



## More than 100,000 Products Available!

### • Temperature

Calibrators, Connectors, General Test and Measurement Instruments, Glass Bulb Thermometers, Handheld Instruments for Temperature Measurement, Ice Point References, Indicating Labels, Crayons, Cements and Lacquers, Infrared Temperature Measurement Instruments, Recorders Relative Humidity Measurement Instruments, RTD Probes, Elements and Assemblies, Temperature & Process Meters, Timers and Counters, Temperature and Process Controllers and Power Switching Devices, Thermistor Elements, Probes and Assemblies, Thermocouples Thermowells and Head and Well Assemblies, Transmitters, Wire

### • Flow and Level

Air Velocity Indicators, Doppler Flowmeters, Level Measurement, Magnetic Flowmeters, Mass Flowmeters, Pitot Tubes, Pumps, Rotameters, Turbine and Paddle Wheel Flowmeters, Ultrasonic Flowmeters, Valves, Variable Area Flowmeters, Vortex Shedding Flowmeters

### • pH and Conductivity

Conductivity Instrumentation, Dissolved Oxygen Instrumentation, Environmental Instrumentation, pH Electrodes and Instruments, Water and Soil Analysis Instrumentation

### • Data Acquisition

Auto-Dialers and Alarm Monitoring Systems, Communication Products and Converters, Data Acquisition and Analysis Software, Data Loggers Plug-in Cards, Signal Conditioners, USB, RS232, RS485 and Parallel Port Data Acquisition Systems, Wireless Transmitters and Receivers

### • Pressure, Strain and Force

Displacement Transducers, Dynamic Measurement Force Sensors, Instrumentation for Pressure and Strain Measurements, Load Cells, Pressure Gauges, Pressure Reference Section, Pressure Switches, Pressure Transducers, Proximity Transducers, Regulators, Strain Gages, Torque Transducers, Valves

### • Heaters

Band Heaters, Cartridge Heaters, Circulation Heaters, Comfort Heaters, Controllers, Meters and Switching Devices, Flexible Heaters, General Test and Measurement Instruments, Heater Hook-up Wire, Heating Cable Systems, Immersion Heaters, Process Air and Duct, Heaters, Radiant Heaters, Strip Heaters, Tubular Heaters